

TECHNICAL MANUAL

**OPERATOR'S,
AVIATION UNIT,
AND INTERMEDIATE
MAINTENANCE MANUAL
(INCLUDING REPAIR PARTS
AND SPECIAL TOOLS LIST)**

FOR

TESTER, PITOT AND STATIC SYSTEM

P/N: 3400-0003

NSN: 4920-01-182-1972

DISTRIBUTION STATEMENT A: Approved for public release; distribution is unlimited.

Headquarters, Department of the Army

29 APRIL 1994



WARNING: A warning highlights a procedure, practice, etc., which, if not correctly followed, could result in personnel injury or loss of life.



Isopropyl alcohol is flammable and toxic. Use with adequate ventilation, gloves and eye protection. Do not use around heat, open flames or sparks.



HIGH VOLTAGE is used in the operation of this equipment. **DEATH ON CONTACT** may result if personnel fail to observe safety precautions. Learn the areas containing high voltage in each piece of equipment. Be careful not to contact high-voltage connections when installing or operating this equipment. Before working inside the equipment, turn power off and ground points of high potential before touching them.

DON'T TAKE CHANCES!

For artificial respiration, refer to FM 21-11.

a/(b blank)

TECHNICAL MANUAL
OPERATOR'S, AVIATION UNIT,
AND INTERMEDIATE
MAINTENANCE MANUAL
INCLUDING REPAIR PARTS
AND SPECIAL TOOLS LIST

FOR
TESTER, PITOT AND STATIC SYSTEM
P/N 3400-0003
(NSN 4920-01-182-1972)

REPORTING OF ERRORS AND RECOMMENDING IMPROVEMENTS You can help improve this manual. If you find any mistakes, or if you know of a way to improve the procedures, please let us know. Mail your letter, DA Form 2028 (Recommended Changes to Publications and Blank Forms), or DA Form 2028-2 located in the back of this manual, directly to: Commander, U.S. Army Aviation and Troop Command, ATM: AMSAT-I-MP, 4300 Goodfellow Boulevard, St. Louis, MO 63120-1798. A reply will be furnished to you.

DISTRIBUTION STATEMENT A. Approved for public release, distribution is unlimited.

TABLE OF CONTENTS

		Page
CHAPTER 1	INTRODUCTION	1-1
Section I	General Information	1-1
Section II	Equipment Description	1-3
Section III	Principles of Operation	1-8
CHAPTER 2	OPERATING INSTRUCTIONS	2-1
Section I	Description and Use of Operator's Controls and Indicators	2-1
Section II	Operator Preventive Maintenance Checks and Services	2-6
Section III	Operation Under Usual Conditions	2-8
Section IV	Operation Under Unusual Conditions	2-11
Section V	Lubrication Level Check.....	2-12

TABLE OF CONTENTS (CONT)

	Page
CHAPTER 3 AVIATION UNIT MAINTENANCE (AVUM)	3-1
Section I Repair Parts, Tools, TMDE, and Support Equipment.....	3-2
Section II Service Upon Receipt	3-3
Section III Preventive Maintenance Checks and Services (PMCS)	3-3
Section IV Troubleshooting	3-8
Section V Maintenance Procedures	3-11
Section VI Preparation for Storage or Shipment	3-14
 CHAPTER 4 AVIATION INTERMEDIATE MAINTENANCE (AVIM).....	 4-1
Section I Repair Parts, Special Tools, TMDE, and Support Equipment	4-1
Section II Service Upon Receipt	4-2
Section III Preventive Maintenance Checks and Services (PMCS)	4-3
Section IV Troubleshooting	4-5
Section V Maintenance Procedures	4-8
 APPENDIX A REFERENCES.....	 A-1
APPENDIX B MAINTENANCE ALLOCATION CHART.....	B-1
Section I Introduction.....	B-1
Section II Maintenance Allocation Chart	B-3
Section III Tools and Test Equipment Requirements.....	B-7
Section IV MAC Reference Code and Remarks	B-8
 APPENDIX C REPAIR PARTS AND SPECIAL TOOLS LIST	 C-1
APPENDIX D EXPENDABLE/DURABLE SUPPLIES AND MATERIALS LIST	D-1
APPENDIX E MANUFACTURED ITEMS LIST	E-1
APPENDIX F TORQUE LIMITS	F-1
APPENDIX G ELECTRICAL SCHEMATICS	G-1
INDEX.....	INDEX-1

HOW TO USE THIS MANUAL

1. Take a few minutes to look through this manual. We've designed this manual so that it will be easy for you to find and perform the procedures you need.
2. If the Pitot and Static Systems Tester needs repair and you know what's wrong with it, here's what you do:
 - a. Turn to the index and check for a paragraph on the component you want to remove and replace.
 - b. Turn to the paragraph. Under the paragraph title, you'll find the tools, materials, and equipment condition needed to perform the procedure. If there are no tools or materials needed, it will also be noted here. If you have more than one of a specific type of tool (for example, two different screwdrivers) the text will indicate which tool to use in the necessary steps. If there is no equipment condition needed to prepare the Pitot and Static Systems Tester for the removal procedure, it will be noted that the Pitot and Static Systems Tester is assembled.
 - c. To remove the bad component, perform the removal procedure.
 - d. To install the new component, perform the replacement procedure. The Pitot and Static Systems should now be ready to operate.
3. If the Pitot and Static Systems Tester needs repair and you don't know what's wrong with it, you go to the troubleshooting procedures. Troubleshooting procedures will direct you to the appropriate paragraph to repair your unit.

**CHAPTER 1
INTRODUCTION**

<u>CHAPTER CONTENTS</u>		<u>PAGE</u>
Section I.	GENERAL INFORMATION	1-1
Section II.	EQUIPMENT DESCRIPTION	1-3
Section III.	PRINCIPLES OF OPERATION	1-8

Section I. General Information

<u>SECTION CONTENTS</u>	<u>PARA</u>	<u>PAGE</u>
SCOPE	1-1	1-2
MAINTENANCE FORMS, RECORDS, AND REPORTS	1-2	1-2
DESTRUCTION OF ARMY MATERIEL TO PREVENT ENEMY USE	1-3	1-2
ADMINISTRATIVE STORAGE	1-4	1-2
REPORTING EQUIPMENT IMPROVEMENT RECOMMENDATIONS (EIRS)	1-5	1-2

1-1. SCOPE

This manual contains operation, maintenance, and illustrated parts breakdown, and repair parts list for Pitot and Static Systems Tester, Part Number: 3400-0003 illustrated below.

The Pitot and Static Systems Tester is a portable, self-contained field instrument which is used for checking the performance characteristics of vacuum and pressure aircraft instruments, and Pitot and Static systems. The Tester accurately simulates the airspeed and atmospheric pressures which are present during normal operation of the aircraft.

The Pitot and Static Systems Tester is capable of testing the aircraft Pitot and Static systems and simulating aircraft airspeed, altitude, and rate of climb ascending or descending for aircraft instrument tests.

1-2. MAINTENANCE FORMS, RECORDS, AND REPORTS

Department of the Army forms and procedures used for equipment maintenance will be those prescribed by DA PAM 738-751, Functional User's Manual for The Army Maintenance Management System-Aviation (TAMMS-A).

1-3. DESTRUCTION OF ARMY MATERIEL TO PREVENT ENEMY USE

Refer to TM 750-244-1-4, Electrical Material, Procedures for Destruction to Prevent Enemy Use.

1-4. ADMINISTRATIVE STORAGE

For storage and shipment information, refer to Chapter 3.

1-5. REPORTING EQUIPMENT IMPROVEMENT RECOMMENDATIONS (EIRS)

If your equipment needs improvement, let us know. Send us an EIR. You, the user, are the only one who can tell us what you don't like about your equipment. Let us know why you don't like the design, put it on an SF 368 (Quality Deficiency Report). Mail it to us at U.S. Army Aviation and Troop Command ATTN: AMSAT-I-MDO, 4300 Goodfellow Blvd., St. Louis, MO. 63120-1798. We'll send you a reply.

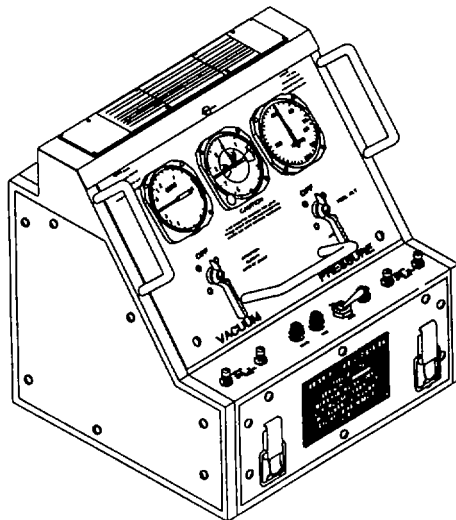

Section II. Equipment Description

<u>SECTION CONTENTS</u>	<u>PARA</u>	<u>PAGE</u>
FUNCTION	1-6	1-3
INPUT POWER	1-7	1-3
LOCATION AND DESCRIPTION OF MAJOR COMPONENTS	1-8	1-4
EQUIPMENT DATA	1-9	1-6

1-6. FUNCTION

The Pitot and Static Systems Tester is a pneumatic testing system that simulates aircraft airspeed from 0-400 knots; altitude from -1000 to 35,000 feet; and rate of climb from ±6000 feet per minute. Pitot and Static Systems Tester can also be tested for leakage. The control panel of the Tester contains the three (3) appropriate aircraft instruments: Rate of Climb, Altimeter, and Airspeed Indicator.

1-7. INPUT POWER

The Tester contains three power cables and one cable adapter to permit operation from the following power sources:

- 28 + 4, -6 volts DC
- 115 volts AC ± 10 percent, 50 to 500 cycles, single phase.
- 115 volts AC ± 10 percent, 50 to 500 cycles, three phase.

1-8. LOCATION AND DESCRIPTION OF MAJOR COMPONENTS

The equipment furnished with the Pitot and Static Systems Tester is shown below.

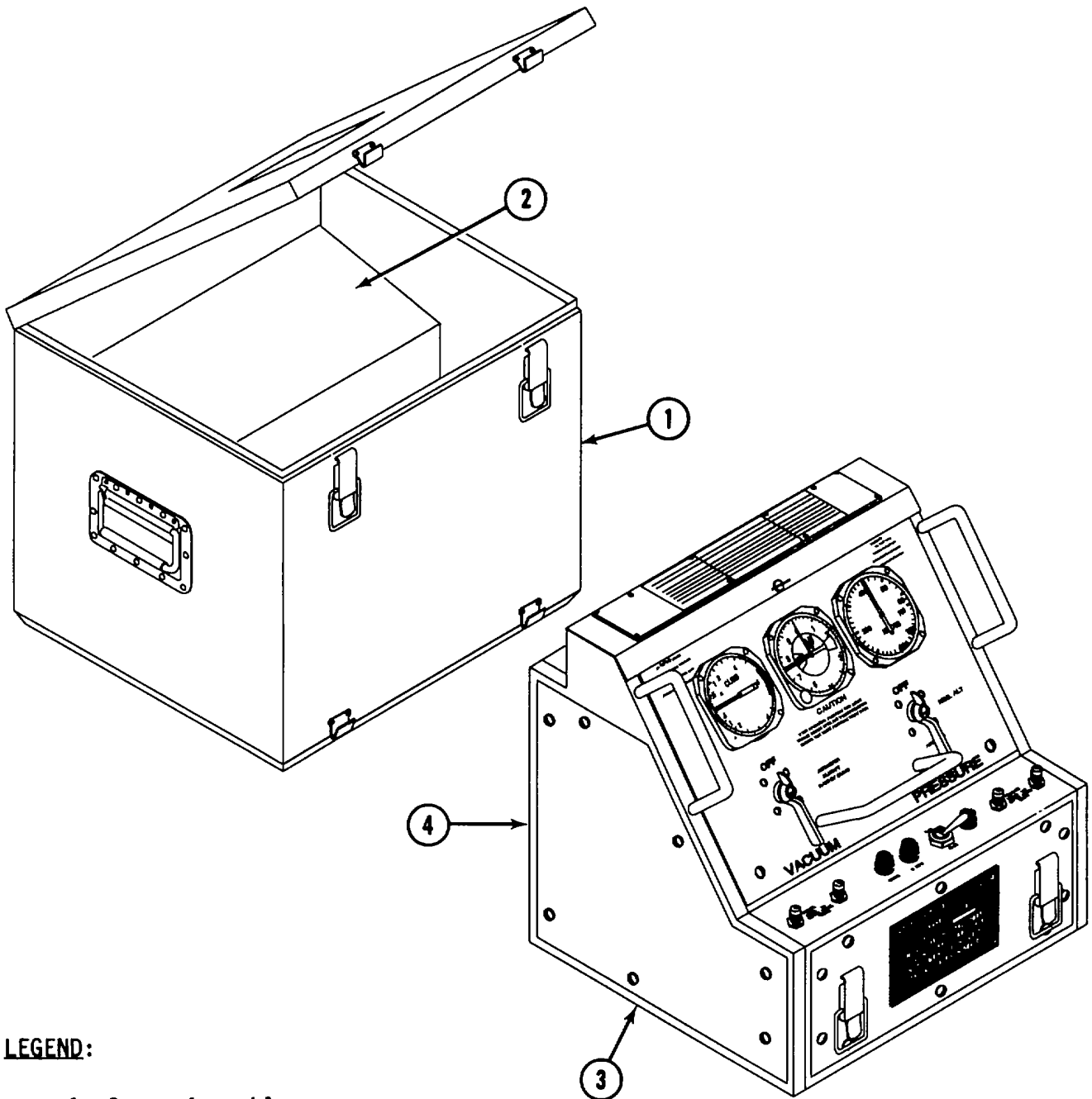

LEGEND:

- 1. Cover Assembly
- 2. Accessory Compartment
- 3. Bottom Plate Assembly
- 4. Frame Assembly

1-8. LOCATION AND DESCRIPTION OF MAJOR COMPONENTS (CONT)

1-8.1. Cover Assembly.

The Tester is 16.6 inches long, 14.5 inches deep and 17.0 inches high when contained within its removable cover for transit. The cover contains accessories necessary for proper operation of the Tester. When the cover is removed, all operating controls, indicators, and accessories are accessible for immediate use.

1-8.2. Frame Assembly.

The frame assembly of the Pitot and Static Systems Tester contains three aircraft instruments: rate of climb, altimeter and airspeed indicator. Vacuum and pressure controls, bleed needle values, a vacuum selector valve, a pressure selector valve, and an "ON-OFF" valve for each of the three respective instruments are also clearly marked on the control panel. Also contained on the control panel are the on-off power switch, press to test button, and 5 amp fuse. A spare fuse is mounted on top of the frame assembly.

1-8.3. Back Plate.

The back plate contains two ports: A "Static" port and a "Pitot" port for hook-up to the same respective ports on the aircraft. Hoses and adapters are provided in the accessory storage compartment. Also, a power connector is provided through which AC and DC power is supplied to the tester.

1-8.4. Interior Components.

For access to interior components of Tester, captive fasteners on the control panel are released and the panel is then swung upward to the "Open" position; with the panel open, the motor-pump assembly, oil reservoir assembly and electrical power supply components are easily accessible as are adjustable pressure/vacuum relief valves, a system pressure relief safety valve, and all fittings and hoses. In addition, rigid pressure lines could be removed if necessary. Located on the side of the box is a clear window, which permits observation of fluid level in the oil reservoir.

1-8.5. Accessories.

An accessory storage compartment is housed within the Tester cover and is accessible when the cover is open or removed from the Tester. Accessories supplied with the Tester are listed below:

<u>Accessory/Description</u>	<u>Qty</u>
AC Power cable, 9 feet, 3 inches (80-10113A)	1
DC Power cable, 9 feet (80-10111)	1
AC Power adapter cable, 8 feet (80-10110A)	1
Adapter cable, three phase AC, 12.5 inches (80-10112A)	1
Clamp assembly, static (92-10113)	1
Hose assembly, 15 inch (92-10114-6)	1
Hose assembly, 5 feet, (AN6270-4D0060)	1
Hose assembly, 6 feet, (AN6270-4D0072)	2
Pitot head adapter (9210118)	1
Hose clamp (AN737TW-48)	1
Fitting, AN815-4D	2

1-9. EQUIPMENT DATA

Refer to Table 1-1 for summary of capabilities, limitations, and other critical operation and maintenance data.

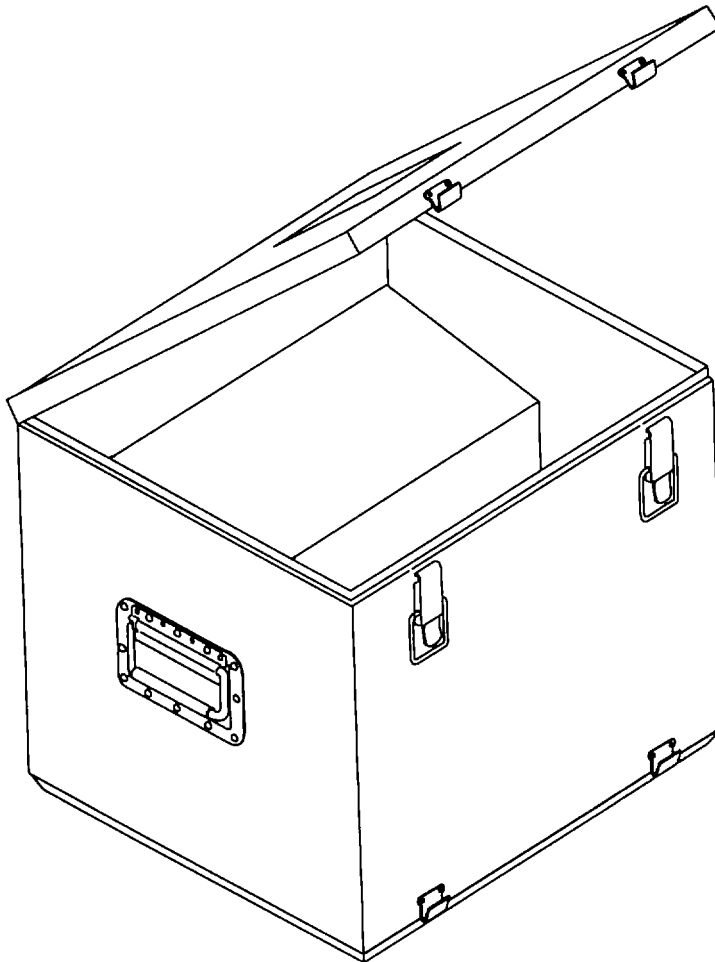

1-9. EQUIPMENT DATA (CONT)

TABLE 1-1. Equipment Data.

Case Dimensions:	
Depth	14.50 inches
Width	16.60 inches
Height	17.00 inches
Weight: (complete with accessory kit)	60 lbs. maximum
Voltage input AC	115 VAC \pm 10%, 50-500 cycles per second, single phase.
	115 VAC \pm 10%, 50-500 cycles per second, three-phase.
Voltage Input DC	28 Volt Direct Current (DC) +4 volts, -6 volts
Usable Temperature Range	-40° C to +50° C
Power Consumption	120 Watts Maximum
Tester Ranges:	
Rate of Climb	\pm 6000 feet/Min \pm 6000 feet/Min
Altimeter	-1000 feet to 35,000 feet
Airspeed	0-400 knots

Section III. Principles Of Operation

1-10. PRINCIPLES OF OPERATION

A small high-speed pump serves dual functions by producing system vacuums up to 29 inches of mercury and system pressures up to 6.5 psi to simulate aircraft atmospheric and airspeed conditions. These vacuums and pressures are delivered to the respective aircraft system and tester instruments through oil reservoir, oil sumps, and a network of hoses, rigid pressure lines, fittings, adapters, valves and ports on the tester along with external hoses and adapters supplied with the tester.

The pump serves the dual function of developing pressure as well as vacuum for operation of the Tester. In the pressure section, a mixture of air and oil is pumped into the reservoir where the oil and air are separated. The separated oil drops to the bottom of the reservoir where it is bled to the pump for lubrication purposes, the air being forced out at the top of the reservoir under pressure. The pressurized air, after going through the check valve whose function is to prevent oil from entering instrument lines during operation, enters an oil sump and passes through a filter which is an integral part of the sump. Air from the sump blows through two pressure control valves. The pressure INCREASE valve controls the amount of air permitted in the system and the pressure DECREASE valve opens the line to the ambient air, allowing system pressure to bleed off. The available pressure level, as fixed by the control valves is sent to the pressure relief valve and PRESSURE selector valve. Setting the PRESSURE selector valve at the desired test position completes the circuit to the instrument under test and the master instrument to one of the pressure relief valves. The pressure relief valve is in the line at all times and protects the instruments from pressure overload when the pump is producing vacuum which passes through the check valve, and the sump which prevents oil from entering the instrument lines. The vacuum INCREASE valve controls the amount of vacuum in the system and the vacuum DECREASE valve opens the line to the ambient air allowing the system vacuum to bleed off.

**CHAPTER 2
OPERATING INSTRUCTIONS**

<u>CHAPTER CONTENTS</u>		PAGE
Section I.	DESCRIPTION AND USE OF OPERATOR CONTROLS AND INDICATORS	2-1
Section II.	OPERATOR PREVENTIVE MAINTENANCE CHECKS AND SERVICES	2-6
Section III.	OPERATION UNDER USUAL CONDITIONS	2-8
Section IV.	OPERATION UNDER UNUSUAL CONDITIONS	2-11
Section V.	LUBRICATION LEVEL CHECK	2-12

Section I. Description And Use Of Operator Controls And Indicators

<u>SECTION CONTENTS</u>	PARA	PAGE
GENERAL	2-1	2-2
PRE-OPERATION PROCEDURES	2-2	2-2
CONTROLS AND INDICATORS	2-3	2-3

2-1. GENERAL

This chapter contains instructions for operating the Pitot and Static Systems Tester. Operating personnel should be familiar with aircraft Pitot and Static systems and instruments to be tested.

2-2. PRE-OPERATION PROCEDURES

CAUTION

Handle the tester with care as the delicate instrumentation it incorporates can easily be damaged by shock of improper handling procedures.

CAUTION

To prepare the tester for use; set the tester on a level bench or platform with an AC or DC power source available.

CAUTION

DO NOT force-tighten control valves; damage will occur to the needle point of the valve.

CAUTION

Set power ON-OFF switch to OFF, close four Vacuum and Pressure control valves and set VACUUM and PRESSURE selector valves to off.

CAUTION

Power source voltage must be within limits specified in paragraph 1-7; or damage will cause a blown fuse.

If AC power is used, connect AC power cable to power connector on rear panel. Connect single-phase adapter cable to free end of AC power cable if single phase power is used.

If DC power is used, connect DC power cable to power connector on rear panel and, observing polarity, connect clips of DC power cable to DC power source.

2-3. CONTROLS AND INDICATORS

- a. General. This section describes and furnishes the operator with sufficient information pertaining to the various controls and indicators provided for the proper operation of the equipment.
- b. Power Switch (1). The single pole, double throw, toggle-type power switch, has an OFF position which opens the circuit and shuts off the electrical power supply to the tester. The ON position is in the circuit to provide electrical current to the tester when the power source is connected.
- c. Indicator light (2). The indicator light illuminates when the power circuit in the tester is operating.
- d. Cartridge fuse (3). The 28 V dc, 5 amp cartridge fuse provides protection against an excessive flow of current which would damage the electrical system.
- e. Vacuum Selector Knob (4). The vacuum selector knob has three positions, and operates a valve which controls the vacuum systems required to test aircraft instruments.
- f. Pressure Selector Knob (5). The pressure selector knob has three positions and operates a valve which controls the pressure systems required to test aircraft instruments.
- g. Pressure Bleed Down Knob (6). Counterclockwise rotation of pressure bleed down knob opens a needle valve allowing system pressure to bleed off. ROTATE clockwise for pressure up.
- h. Pressure Control Knob (7). Counterclockwise rotation of pressure control knob opens a needle valve allowing pressure in system to increase.
- i. Vacuum Bleed Knob (8). Counterclockwise rotation of vacuum bleed knob permits system vacuum to bleed off. ROTATE clockwise for vacuum up.
- j. Vacuum Control Knob (9). Counterclockwise rotation of vacuum control knob opens a needle valve and provides increased vacuum in system.
- k. Shut-off Valves (10). Shut-off valves located on the top of the operator panel are provided for testing aircraft instruments and checking the master instruments for leaks.
- l. Altimeter Indicator (11). The altimeter indicator measures from -1,000 feet below to 35,000 feet above sea level at a rate of $\pm 6,000$ feet per minute.

2-3. CONTROLS AND INDICATORS (CONT)

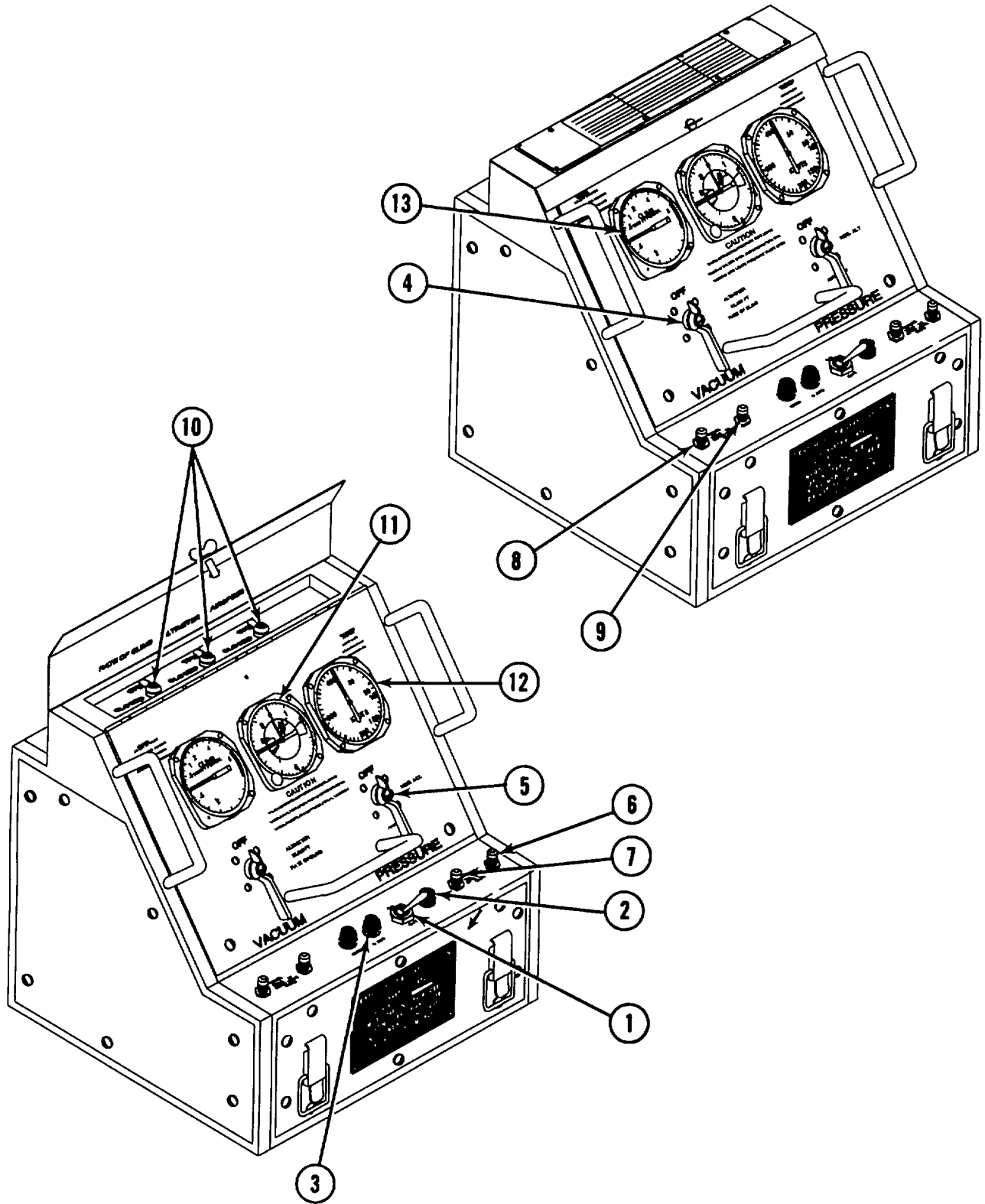

2-3. CONTROLS AND INDICATORS (CONT)

- m. Airspeed Indicator (12). The airspeed indicator measures the differential between Pitot and static pressures created by the tester in a range between 0 and 400 knots and is used to test the accuracy of airspeed indicators.
- n. Rate of Climb Indicator (13). The rate of climb indicator measures the rate of change during climb or dive of altimeter (aircraft). Do not run tester at a rate exceeding 5,000 feet per minute.
- o. Fill and Run Selector Valve (1). The selector valve (1) is in line between the oil reservoir (2) and the pump (3) as shown. The handle (4) on the valve has three positions for use as follows:
 - (1) The direction as shown is for "normal operations".
 - (2) When the valve is turned 90 degrees counter clockwise it is in the fill position.
 - (3) When the valve is turn 90 degrees clockwise it is in the drain position.

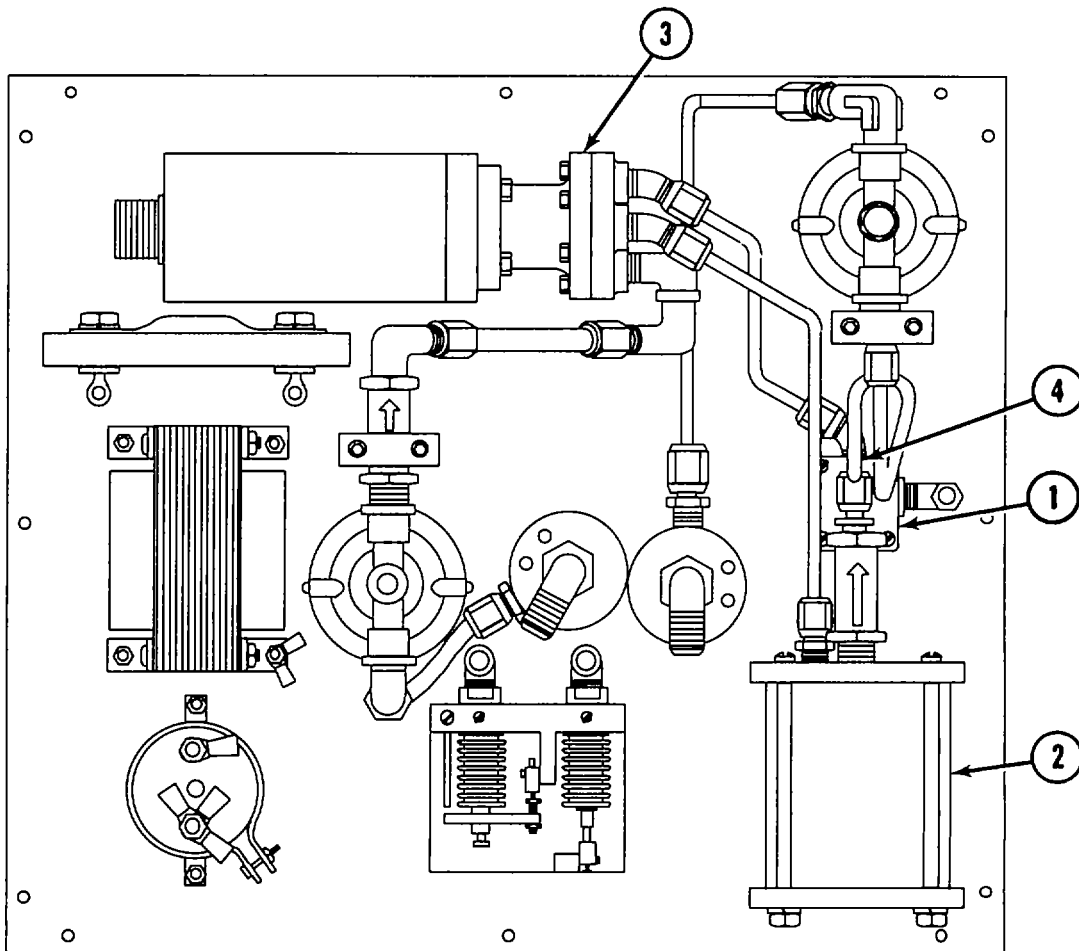

Section II. Operator Preventive Maintenance Checks And Services

<u>SECTION CONTENTS</u>	<u>PARA</u>	<u>PAGE</u>
BEFORE YOU OPERATE	2-4	2-6
PERFORMANCE CHECK	2-5	2-7

2-4. BEFORE YOU OPERATE

Always keep in mind CAUTIONS and WARNINGS. Handle the Pitot and Static tester like you would any other delicate piece of electronic equipment. See Table 2-1 for normal preventive maintenance checks and services.

NOTE

Within designated interval, these checks are to be performed in the order listed.

B - Before A - After

TABLE 2-1. Operator/Crew Preventive Maintenance Checks and Services.

Item No.	Inter-val		Item to be Inspected	Procedures Check for and have repaired or adjust as necessary	Equipment is not ready/ available if contents wet
	B	A			
01	B		Oil level in reservoir	Check oil level before powering and testing	Oil level in reservoir is not between maximum and minimum levels indicated on reservoir body; or damaged
02	B		Cover Assembly	Check for damage to aluminum case, latches and hinges.	
03	B	A	Component Parts	Check for damage or dirt. Clean as necessary.	Indicators, valves, lgt, etc., damaged or broken (return for repair and calibration)
04	B	A	AC-DC Power Cables	Check for loose or broken cables on connectors. Replace as necessary.	Cables require repair

2-5. PERFORMANCE CHECK

Set Tester on level work platform with a source of DC or AC power available.

CAUTION

Ensure oil level within limits before powering up.

Look through window on side of Tester and ensure oil level in reservoir is within MAX. and MIN. indicating lines on oil reservoir. Refer to para. 3-9.

Apply pressure to airspeed indicator in accordance with Table 2-2 readings.

Apply vacuum to Altimeter/Rate-of-Climb in accordance with Table 2-2 readings.

TABLE 2-2. Performance Check

INSTRUMENT	OVERPRESSURE		SYSTEM LEAK		OPERATIONAL RATE
	CHECK POINT	SAFETY RELIEF POINT	CHECK POINT	MAX ALLOWABLE LEAK RATE PER MIN.	
AIRSPEED PRESSURE	400 KNOTS	+20 -0	200 KNOTS	6 KNOTS/MIN.	FULL SCALE- 25 Sec. Mi. 35 Sec. Max.
ALTITUDE (35,000 FT.)	35,000F	+5,000 FT. -0000	25,000 FT.	250 FT/MIN.	RATE OF CLIMB NOT TO EXCEED 5,000 FT. PER MIN. ASCENDING OR DESCENDING
NEGATIVE ALT.	---	---	-1,000 FT.	50 FT./MIN.	RATE OF CLIMB NOT TO EXCEED 5,000 FT. PER MIN. ASCENDING OR DESCENDING

Section III. Operation Under Usual Conditions

<u>SECTION CONTENTS</u>	<u>PARA</u>	<u>PAGE</u>
OPERATING PROCEDURES	2-6	2-8
SHUTDOWN PROCEDURES	2-7	2-10

2-6. OPERATING PROCEDURES

- a. Place Tester on bench or platform where a source of DC or AC power is available.
- b. Connect appropriate power source to connector on rear panel of Tester with appropriate power cable (and adaptor for single phase) per paragraph 2-2.
- c. Close all three instrument shut-off valves on top of operator panel to "OFF" position.
- d. Select aircraft instrument to be tested.

CAUTION

Vacuum valves must be open when operating pressure side; pressure valves must be open when operating vacuum side.

- e. Open "Control" and "Bleed" needle valves of opposite side of Tester selected.
- f. Set appropriate vacuum or pressure selector valve to instrument to be tested selection. Make sure "Control" and "Bleed" needle valves to be used are both closed.
- 9. Open "shut-off" valve for appropriate aircraft instrument to be tested.
- h. Using hoses, connect instrument/aircraft to be tested to appropriate instrument "Pitot or Static" port on rear of Tester.

NOTE

Altimeter and climb tests will be done using the "Static" port whereas airspeed tests will be done using the "Pitot" port. Appropriate hose(s) and fittings for these hook-ups are in the accessory storage compartment.

- i. Turn the power switch to "ON". Indicator will light and motor/pump assembly will start.

2-6. OPERATING PROCEDURES (CONT)

CAUTION

When testing the rate-of-climb indicator and altimeter do not exceed 5000 feet-per-minute up or down.

- j. Open "Control" needle valve to selector valve to test instrument selected. Use small turn to obtain desired deflections and continue opening to obtain maximum deflection of both instrument on tester panel and instrument under test.

RATE OF CLIMB INDICATOR CORRECTION CARD			ALTIMETER INDICATOR				AIRSPEED INDICATOR			
TEST RATE IN FEET PER MINUTE	RATE OF CLIMB	RATE OF DIVE	STANDARD ALTITUDE IN FEET	INDICATOR READING IN FEET	STANDARD ALTITUDE IN FEET	INDICATOR READING IN FEET	STANDARD AIRSPEED IN KNOTS	INDICATOR READING IN KNOTS	STANDARD AIRSPEED IN KNOTS	INDICATOR READING IN KNOTS
500			-1,000		12,000		40		250	
1000			0		14,000		80		250	
1500			500		16,000		120		250	
2000			1,000		18,000		160		250	
2500			1,500		20,000		200		250	
3000			2,000		22,000		240		250	
3500			2,500		24,000		280		250	
4000			3,000		26,000		320		250	
4500			3,500		28,000		360		250	
5000			4,000		30,000		400		250	
5500			4,500		32,000		440		250	
6000			5,000		34,000		480		250	
			5,500		36,000		520		250	
INST No. _____ DATE _____			INST No. _____ DATE _____				INST No. _____ DATE _____			

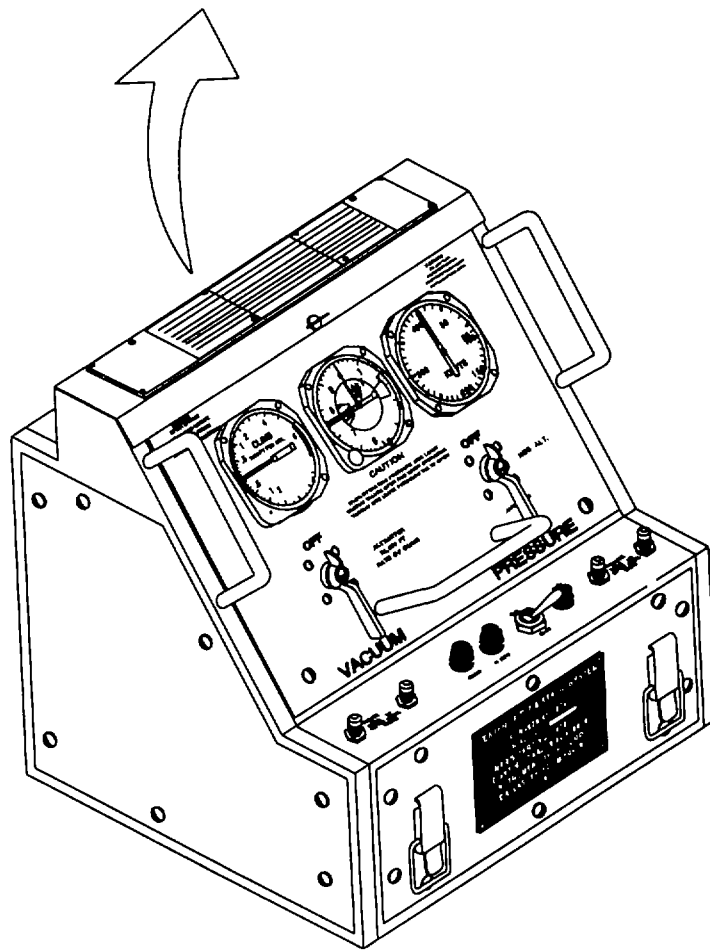

2-7. SHUTDOWN PROCEDURE

To disconnect instrument under test and shut down Tester: After test, open applicable "bleed" needle valve until all instruments read zero.

CAUTION

Do not turn selector valves, or disconnect hoses from test set unless all instruments indicate zero; failing to will cause damage to instruments.

- a. Turn power switch to OFF position.
- b. Close shut-off valves on top of operator panel to OFF positions.
- c. Disconnect instrument under test from appropriate "Pitot" or "Static" port on rear of Tester.
- d. Set "Vacuum" and "Pressure" selector valves to OFF positions and open four vacuum and pressure "Control" and "Bleed" needle valves.
- e. Disconnect Tester from power source.
- f. Return power cables, hoses, adapters, and fittings to accessory storage compartment and return cover to tester.

Section IV. Operation Under Unusual Conditions

<u>SECTION CONTENTS</u>	<u>PARA</u>	<u>PAGE</u>
UNUSUAL CONDITIONS	2-8	2-11
EXTREME ENVIRONMENTAL MAINTENANCE	2-9	2-11

2-8. UNUSUAL CONDITIONS

- a. Normal. The Tester can be carried from one work area to another when the accessories are stowed in the cover compartment.
- b. Extremes of Heat and Cold-unusual conditions. The Tester is designed to operate in temperatures from -40° F to +120°F (-40°C to +50° C). When operating in high temperatures to 120°F, use extreme caution to keep Tester within operating limits. For low temperature operating range (from +32°to -40°F), run the pump for at least 5 minutes with both selector valve knobs in the OFF position and the knobs turned to open valves before starting tests.
- c. Other unusual conditions:

CAUTION

Contamination in the pneumatic system will damage the instruments, controls, and pump.

- (1) When operating the Tester in extreme conditions of snow, ice, rain, mud, dust, salt air or similar conditions; do everything possible to prevent foreign material from entering the Pneumatic System.
- (2) After operation in extreme conditions, thoroughly clean and dry the Tester and accessories.

2-9. EXTREME ENVIRONMENTAL MAINTENANCE

There are no requirements for extreme environmental maintenance for the Pitot and Static Systems Tester.

Section V. Lubrication Level Check**2-10. LUBRICATION LEVEL CHECK**

To prepare the Tester for use; proceed as follows:

- a. Place Tester (1) level on bench or platform
- b. Look through window (2) of the right side of Tester and observe oil level in reservoir. Oil level must be within maximum and minimum limits indicated on oil reservoir body. If oil level is low fill reservoir in accordance with procedure given in para. 3-9.

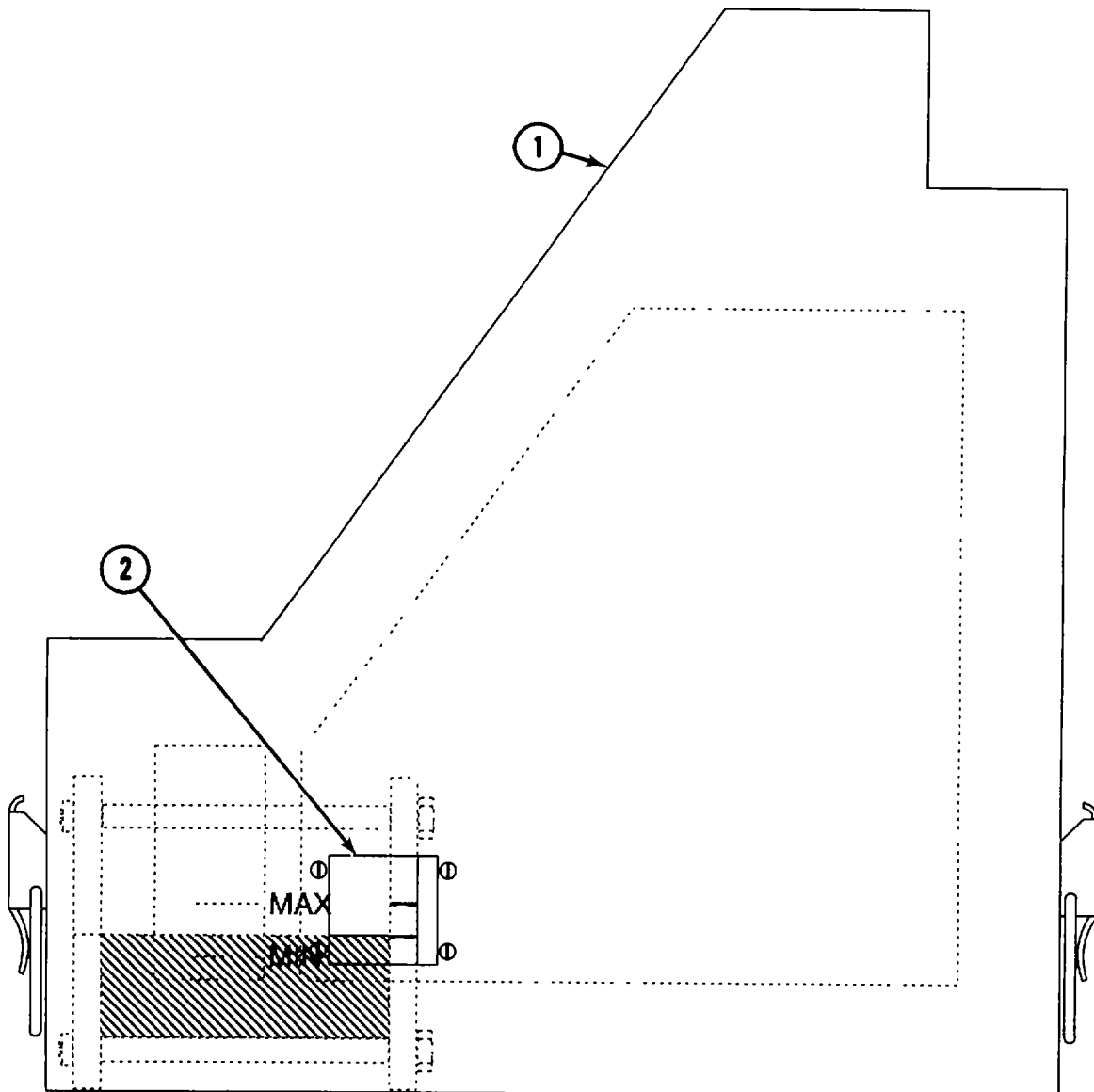

CHAPTER 3

AVIATION UNIT MAINTENANCE (AVUM) INSTRUCTIONS

<u>CHAPTER CONTENTS</u>		<u>PAGE</u>
Section I.	REPAIR PARTS, SPECIAL TOOLS, TMDE, AND SUPPORT EQUIPMENT	3-2
Section II.	SERVICE UPON RECEIPT	3-3
Section III.	PREVENTIVE MAINTENANCE CHECKS AND SERVICES (PMCS)	3-3
Section IV.	TROUBLESHOOTING	3-8
Section V.	MAINTENANCE PROCEDURES	3-11
Section VI.	PREPARATION FOR STORAGE OR SHIPMENT	3-14

3-1. GENERAL

This chapter contains maintenance procedures that are the responsibility of the aviation unit maintenance technician as authorized by the Maintenance Allocation Chart (MAC) and Source Maintenance and Recoverability (SMR) coded items in the Repair Parts and Special Tools List (RPSTL). The maintenance procedures in this chapter are prepared in the form of summary and detailed procedures.

3-2. MAINTENANCE OPERATIONS

These instructions provide the proper technique and detailed procedures required to perform the maintenance operations. Each maintenance operation provides step-by step instructions in the order in which the work is most logically accomplished. Any unusual or critical steps are covered in detail.

Section I. Repair Parts, Special Tools, TMDE, And Support Equipment

<u>SECTION CONTENTS</u>	<u>PARA</u>	<u>PAGE</u>
TOOLS AND TEST EQUIPMENT LIST	3-3	3-2
SPECIAL TOOLS, TMDE, AND SUPPORT EQUIPMENT	3-4	3-2
REPAIR PARTS	3-5	3-2

3-3. TOOLS AND TEST EQUIPMENT LIST

Tools and test equipment required for maintenance of the Pitot and Static System Tester are identified on page B7 to perform the operation.

3-4. SPECIAL TOOLS, TMDE, AND SUPPORT EQUIPMENT

There are no special tools required for test or inspection procedures at the AVUM level.

3-5. REPAIR PARTS

Repair parts are listed in the Repair Parts and Special Tools List (RPSTL), Appendix C of this manual.

Section II. Service Upon Receipt

<u>SECTION CONTENTS</u>	<u>PARA</u>	<u>PAGE</u>
GENERAL	3-6	3-3

3-6. GENERAL

Visually check the exterior of the Pitot and Static Systems Tester for any apparent damage. Check contents to assure that all components listed in the Repair Parts and Special Tools List (RPSTL) of this manual are enclosed and undamaged.

Section III. Preventive Maintenance Checks And Services (PMCS)

<u>SECTION CONTENTS</u>	<u>PARA</u>	<u>PAGE</u>
GENERAL	3-7	3-3
CLEANING	3-8	3-3
FILLING OIL RESERVOIR	3-9	3-4
DRAINING THE OIL SUMPS	3-10	3-6
PERFORMANCE CHECKS	3-11	3-7

3-7. GENERAL

Preventive maintenance for the Pitot and Static Systems Tester is covered by the following paragraphs as well as the Notes and Cautions in Chapter 2, and information listed in Table 2-1. These Notes and Cautions, if followed, assure that the equipment will be used in the proper manner.

3-8. CLEANING

CAUTION

Use a soft cloth dampened with a solution of mild soap and water or isopropyl alcohol (D4) for cleaning.

- a. Keep equipment free of dirt and grease. Place protective cover over tester operator panel and external ports when not in use.
- b. Clean load cells prior to use to assure good mating surfaces for the adapters.

3-9. FILLING OIL RESERVOIR

Whenever the oil level of the reservoir falls below the minimum level indicated on the reservoir body, add oil conforming to MIL-H-5606 until oil is again at its proper level. See para. 2-10.

- a. Remove right door (1) of Pitot static assembly to gain access to the filler valve port (2).
- b. Unscrew cap (3) from nipple fitting on filler valve port (2) pointing upward. Attach filler hose by turning clockwise.
- c. Set the valve handle (4) to the fill position, turning it 90 degrees clockwise.
- d. Once the filler hose is tightened, place the opposite end of the hose in a container of oil, conforming to MIL-H-5606.
- e. On front of chassis, set the power switch to "ON". When oil level is within limits indicated on reservoir body, remove filler hose from oil container to allow for drainage of oil in hose. Set ON-OFF switch to "OFF".
- f. Disconnect the filler hose from the filler valve port (2), reinstall cap (3), and change the selector valve to RUN position as shown.
- g. Install right door (1).
- h. The unit is now ready to perform its functional tests.

<u>Lubricant</u>	<u>Reservoir Capacity</u>	<u>Expected Temperatures</u>	<u>Intervals</u>
Fluid, Hydraulic MIL-H-5606 (D3)	2.5 fl. Oz	All temperatures	D-Daily 6M-6 Months

CAUTION

Do not operate pump for more than 10 seconds without oil in reservoir as it will damage pump.

- (1) Check for the presence of oil in both sump bowls daily when Tester is in use. Oil in sump indicates filters need cleaning or repair.
- (2) The oil in the reservoir shall be cleaned at monthly intervals, or more frequently if conditions warrant.

3-9. FILLING OIL RESERVOIR (CONT)

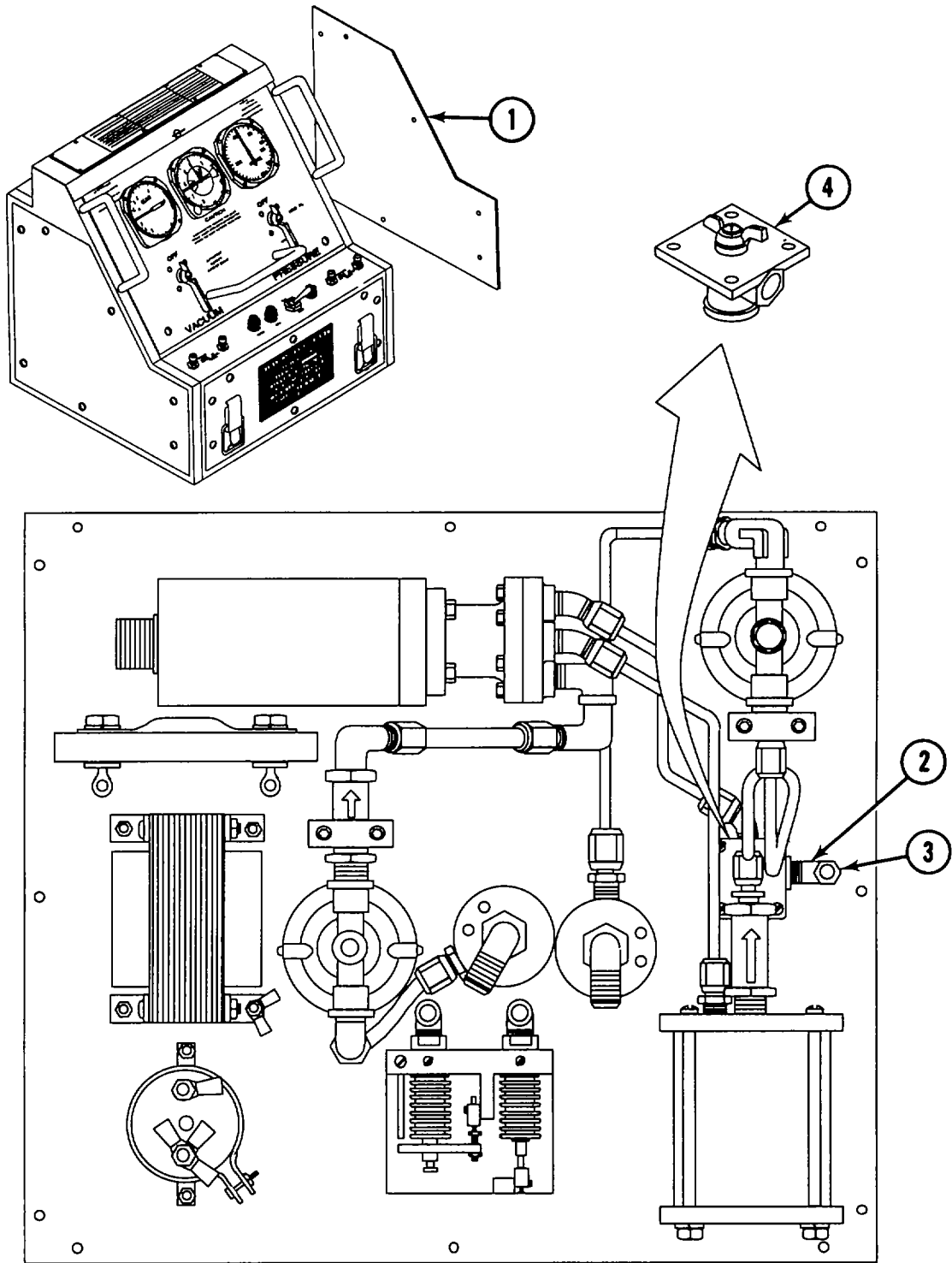

3-10. DRAINING THE OIL SUMPS

The filters in the system are equipped with oil sumps which permit only air to enter the vacuum and pressure lines to the instruments. Once the oil collects to a level occupying more than 50 percent of the total glass area of the sumps, the sumps must be drained. To drain the sumps proceed as follows:

- a. Remove back of tester to gain access to interior.
- b. Loosen star nut (1) and screw (2) by turning counterclockwise.
- c. Swing retainer (3) away from bowl (4).
- d. Remove sump bowl (4) from sump mounting body (5) to empty oil.
- e. Clean sump bowl (4) and filter (6) with a lint free cloth dampened in alcohol (D4).
- f. Install sump bowl (4) into sump mounting body (5).
- g. Swing retainer (3) under bowl (4) and adjust star nut (1) and screw (2) to tighten.
- h. Operate test set for maximum pressure as well as vacuum settings to ensure no system leaks exist.

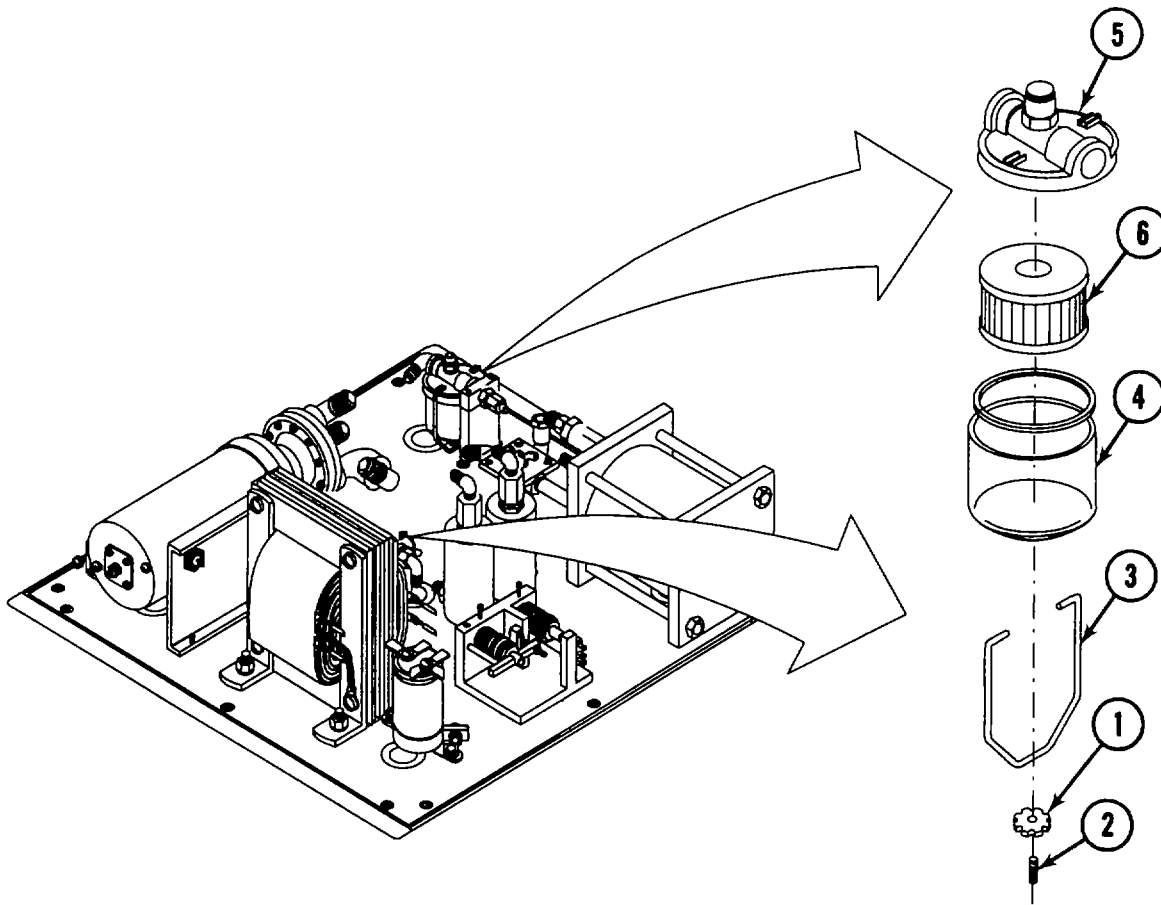

3-11. PERFORMANCE CHECKS

a. A complete performance check of the Pitot and Static Systems Tester is not possible at the Aviation Unit Maintenance (AVUM) level because results cannot be verified without an accurate pressure and vacuum test gage.

b. Visually inspect the Aircraft Pitot and Static Systems Tester accessories, aircraft indicators, switch, fuse, fuseholder, indicator light, needle valves, selector valves, shut-off valves, connector, and power cables. Refer to the tasks in Chapter 3 and 4 for applicable procedures.

Section IV. Troubleshooting

<u>SECTION CONTENTS</u>	<u>PARA</u>	<u>PAGE</u>
GENERAL	3-12	3-8
PITOT AND STATIC SYSTEMS TESTER INSPECTION	3-13	3-9
ACCESSORY STORAGE INSPECTION	3-14	3-10

3-12. GENERAL

Troubleshooting at the Aviation Unit Maintenance (AVUM) level is limited to checking the system for indications of normal operation and inspecting and replacing AC or DC cables and AC or DC fuses.

NOTE

Electrical components (except fuses and power cables) are factory calibrated and will not be replaced or interchanged in the field or erroneous readings may result.

If the unit is inoperative, switch to alternate power source (AC to DC, DC to AC). Check the initial power source for availability of power. If the source is functioning, inspect the appropriate power cable for signs of damaged, shorted or open wiring, or a faulty connector. If the cable checks are reliable, proceed with next task.

3-13. PITOT AND STATIC SYSTEMS TESTER INSPECTION

Personnel Required: 68 F Aircraft Electrician
Parts: Pitot and Static Systems Tester, P/N 3400-0003
Equipment Condition: Power disconnected, tester on work bench, cover removed

- a. Examine tester cover for damage
- b. Check that all operator panel and accessory components are accounted for and undamaged.
- c. Check latches, hinges, and catches for damage.
- d. Replace all missing parts: Refer to Appendix C.
- e. Clean all components.

END OF TASK

3-14. ACCESSORY STORAGE INSPECTION

Personnel Required: 68F Aircraft Electrician
Parts: Accessory Storage Compartment Components.
Equipment Conditions: Power disconnected, cover removed from tester, storage compartment door open

3-14.1. INSPECTION

- a. Check that all components are accounted for and undamaged. Refer to Appendix C, figure C-1.
- b. Account for the following components.

<u>ITEM</u>	<u>QTY</u>	<u>DESCRIPTION</u>
1	1	5 ft. hose assembly
2	2	6 ft. hose assembly
3	1	15 in. hose assembly (filler hose)
4	1	Adapter cable
5	1	DC power cable
6	2	AC 3-phase power cable
7	1	AC single phase cable
8	1	Pitot connector
9	1	Hose Clamp
10	2	Union Flared Tube Fitting
11	1	Clamp assembly, static

3-14.2. REMOVAL

Remove any worn or damaged components from the storage compartment.

3-14.3. INSTALLATION

Install new part(s) in storage compartment to replace worn or damaged components.

END OF TASK

Section V. Maintenance Procedures

<u>SECTION CONTENTS</u>	<u>PARA</u>	<u>PAGE</u>
FUSE REMOVAL AND REPLACEMENT	3-15	3-11
LAMP (BULB) REMOVAL & REPLACEMENT	3-16	3-13

3-15. FUSE REMOVAL AND REPLACEMENT
(Sheet 1 of 2)

Personnel Required: 68F Aircraft Electrician
Parts: Fuse, 5 AMP., P/N 6610084
Equipment Condition: Power disconnected, cover removed

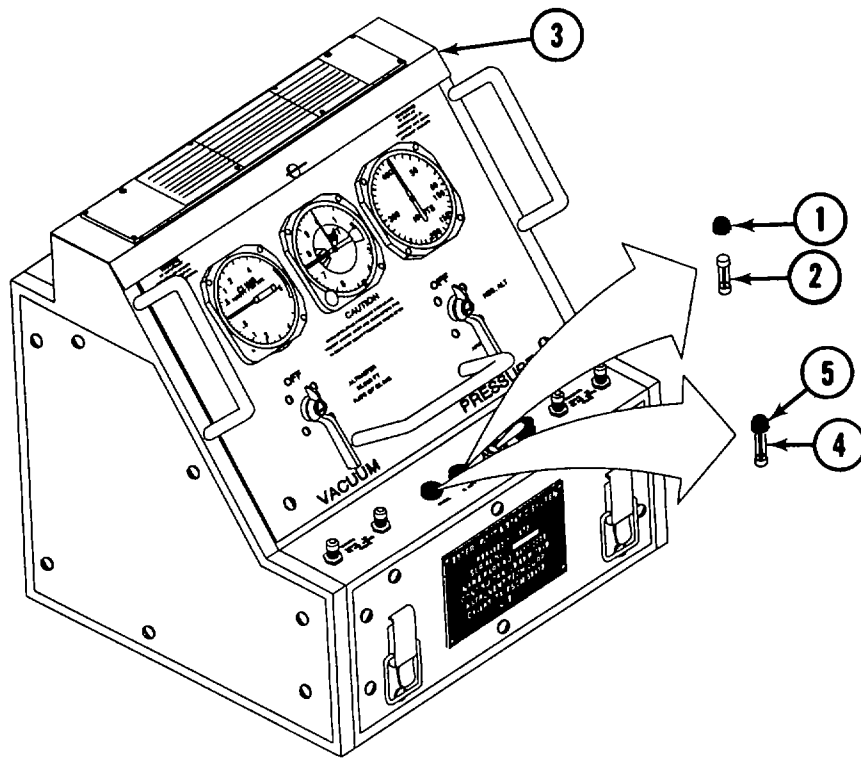

3-15.1. REMOVAL

- a. Remove fuse holder cap (1) and fuse (2) from chassis (3) turning 90 degrees counterclockwise.
- b. Remove fuse (2).
- c. Remove spare fuse (4) from spare fuse holder (5).

GO TO NEXT PAGE

3-15. FUSE REMOVAL AND REPLACEMENT (Cont)
 (Sheet 2 of 2)

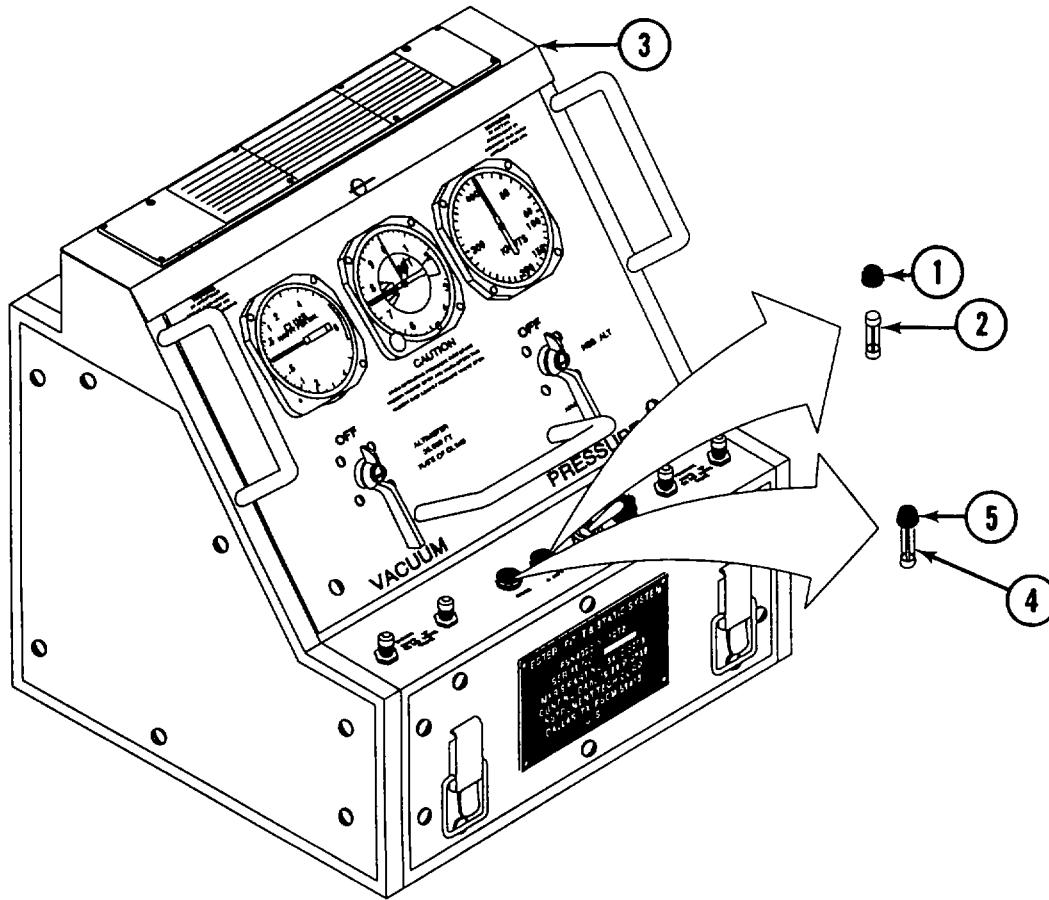

3-15.2. INSTALLATION

- a. Install fuse (4) into fuse holder cap (1) and place it into chassis (3). Press down while turning 90 degrees clockwise.
- b. Install spare fuse holder (5) into chassis (3).

END OF TASK

3-16. LAMP (BULB) REMOVAL AND REPLACEMENT

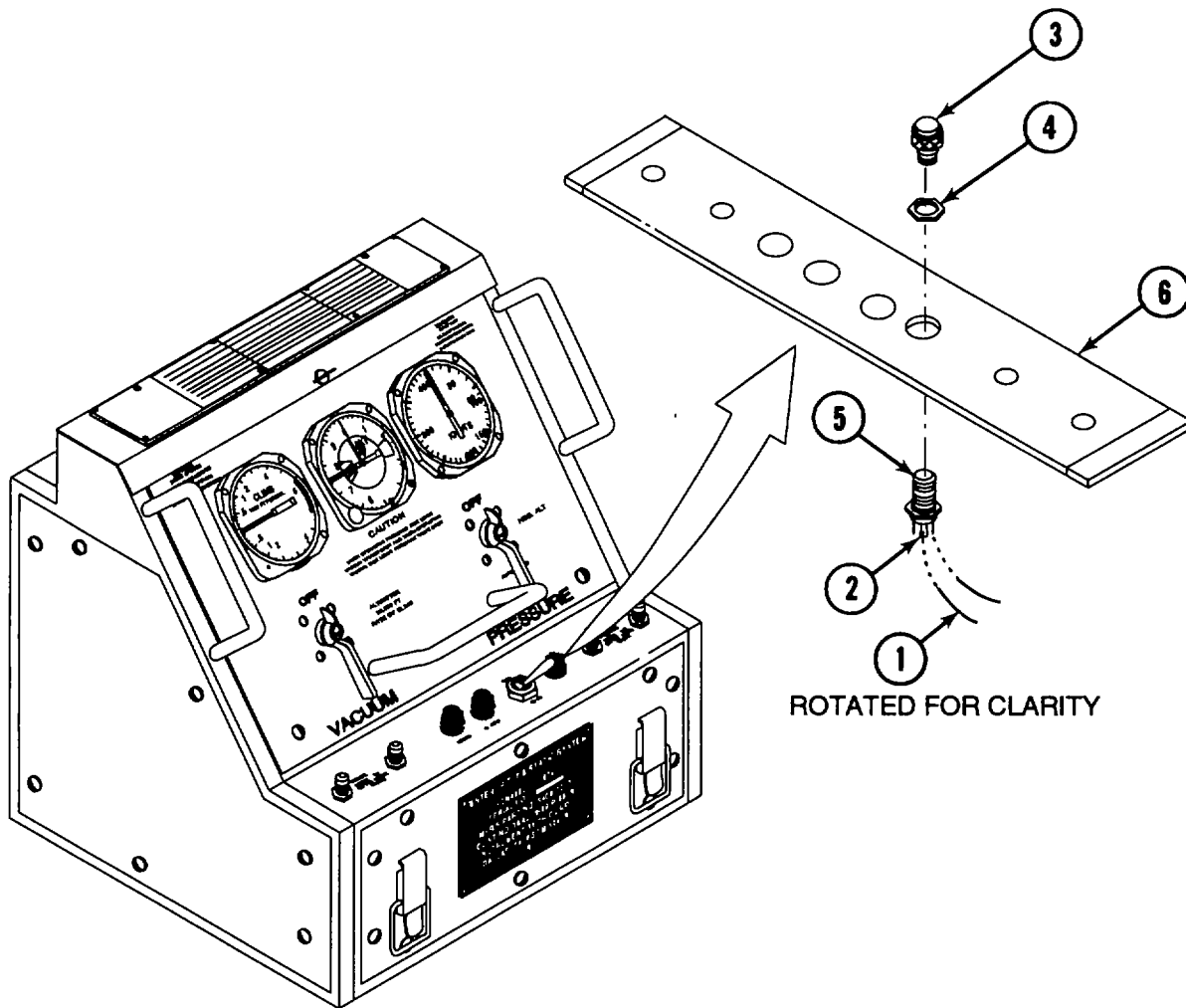

3-16.1. REMOVAL

- a. Tag and unsolder two wires (1) from light assembly leads (2).
- b. Remove pilot lamp (3) by turning it counterclockwise.
- c. Remove mounting nuts (4) from light assembly (5) and remove light assembly (5) from operator panel (6).

3-16.2. INSTALLATION

- a. Turn pilot lamp (3) clockwise into light assembly (5) and hand tighten.
- b. Install light assembly (5) into operator panel (6) and secure with mounting nuts (4).
- c. Solder two wires (1) to light assembly leads (2) using solder (D5).

END OF TASK

Section VI. Preparation For Storage Or Shipment

<u>SECTION CONTENTS</u>	<u>PARA</u>	<u>PAGE</u>
PREPARATION FOR STORAGE	3-17	3-14
PREPARATION FOR SHIPMENT	3-18	3-14

3-17. PREPARATION FOR STORAGE

The Pitot and Static Systems Tester may be stored using normal procedures. Instructions are provided in TM1-1500-204-23 (series). The case is drip proof when lid is closed and secured.

3-18. PREPARATION FOR SHIPMENT

Preservation and packaging shall be level A or Level C. Packing shall be Level A, Level B, or Level C of Specification MIL-P-116.

CHAPTER 4

**AVIATION INTERMEDIATE MAINTENANCE (AVIM)
MAINTENANCE INSTRUCTIONS**

<u>CHAPTER CONTENTS</u>		<u>PAGE</u>
Section I.	REPAIR PARTS, SPECIAL TOOLS, TMDE, AND SUPPORT EQUIPMENT	4-1
Section II.	SERVICE UPON RECEIPT	4-2
Section III.	PREVENTIVE MAINTENANCE CHECKS AND SERVICES (PMCS)	4-3
Section IV.	TROUBLESHOOTING	4-5
Section V.	MAINTENANCE PROCEDURES	4-8

Section I. Repair Parts, Special Tools, TMDE, and Support Equipment

<u>SECTION CONTENTS</u>	<u>PARA</u>	<u>PAGE</u>
GENERAL	4-1	4-1
MAINTENANCE OPERATIONS	4-2	4-2
TOOLS AND TEST EQUIPMENT LIST	4-3	4-2
REPAIR PARTS	4-4	4-2

4-1. GENERAL

This chapter contains maintenance procedures that are the responsibility of the Aviation Intermediate Maintenance (AVIM) technician as authorized by the Maintenance Allocation Chart (MAC) and Source, Maintenance and Recoverability (SMR) coded items in the Repair Parts and special Tools List (RPSTL). The maintenance procedures in this chapter are prepared in the form of summary and detailed procedures.

4-2. MAINTENANCE OPERATIONS

These instructions provide the proper technique and detailed procedures required to perform the maintenance operations. Each maintenance operation provides step-by-step instructions in the order in which the work is most logically accomplished. Any unusual or critical steps are covered in detail.

4-3. TOOLS AND TEST EQUIPMENT LIST

For authorized tools and test equipment refer to Appendix B.

4-4. REPAIR PARTS

Repair parts are listed in the Repair Parts and Special Tools List (RPSTL), APPENDIX C, of this manual.

Section II. Service Upon Receipt

4-5. GENERAL

- a. Visually check the exterior of the Pitot and Static Systems Tester for apparent damage. Check contents to assure that all components listed in APPENDIX C (RPSTL) of this manual are enclosed and undamaged.
- b. If the equipment has been damaged, report the damage on SF 368, (REPORT OF DISCREPANCIES). Check the equipment against the packing slip to see if the shipment is complete. Report any discrepancies in accordance with the instructions of DA PAM 738-751.

Section III. Preventive Maintenance Checks And Services (PMCS)

<u>SECTION CONTENTS</u>	<u>PARA</u>	<u>PAGE</u>
GENERAL	4-6	4-3
CLEANING	4-7	4-3
LUBRICATION	4-8	4-3
EXTREME ENVIRONMENTAL MAINTENANCE	4-9	4-3
CALIBRATION	4-10	4-4

4-6. GENERAL

Inspect Pitot and Static Systems Tester for missing or damaged components. Check for physical damage such as breaks, cracks, wear, etc.

4-7. CLEANING



Isopropyl alcohol is flammable and toxic. Use with adequate ventilation, gloves and eye protection. Do not use around heat, open flames or sparks.

Use a soft cloth dampened with isopropyl alcohol for cleaning. Keep equipment free of dirt and grease.

Place protective cover over the tester when not in use.

4-8. LUBRICATION

Perform the following services before operating the Tester.

Lubricate in accordance with instructions contained in para. 3-9.

Perform the before operation services listed in the Operator's/Crew preventive maintenance checks and services table 2-1.

4-9. EXTREME ENVIRONMENTAL MAINTENANCE

There are no requirements for extreme environmental maintenance for the Pitot and Static Systems Tester.

4-10. CALIBRATION

Calibration of the Pitot and Static Systems Tester will be performed by a TMDE Support Team, in accordance with guidelines specified in Calibration and Repair Requirements for the Maintenance of Army Material (TB 43-180).

Section IV. Troubleshooting

<u>SECTION CONTENTS</u>	<u>PARA</u>	<u>PAGE</u>
GENERAL	4-11	4-5
PITOT AND STATIC SYSTEMS TESTER INSPECTION/FAULT ISOLATION	4-12	4-5
TROUBLESHOOTING PROCEDURE 1: MOTOR AND/OR INDICATOR LAMP DOES NOT TURN ON	4-13	4-6
TROUBLESHOOTING PROCEDURE 2: TESTER DOES NOT BUILD OR HOLD PRESSURE (AIRSPEED/VACUUM ALTIMETER)	4-14	4-7

4-11. GENERAL

A list of possible failures to the Pitot and Static Systems Tester as well as probable cause and corrective action are shown in the following fault isolation block diagrams. Corrective actions, as shown in the following trouble shooting diagram, are outlined in the applicable removal/replacement paragraphs in the text of this manual.

4-12. PITOT AND STATIC SYSTEMS TESTER INSPECTION/FAULT ISOLATION

- Personnel Required:** 35H Test, Measurement Diagnostic Equipment (TMDE) Support Specialist
- Tools/Test and Support Equipment:** Tool Kit (B2) or Shop Set (B4)
- Equipment Conditions:** Tester on work bench

4-13. TROUBLESHOOTING PROCEDURE 1: MOTOR AND/OR INDICATOR LAMP DOES NOT TURN ON

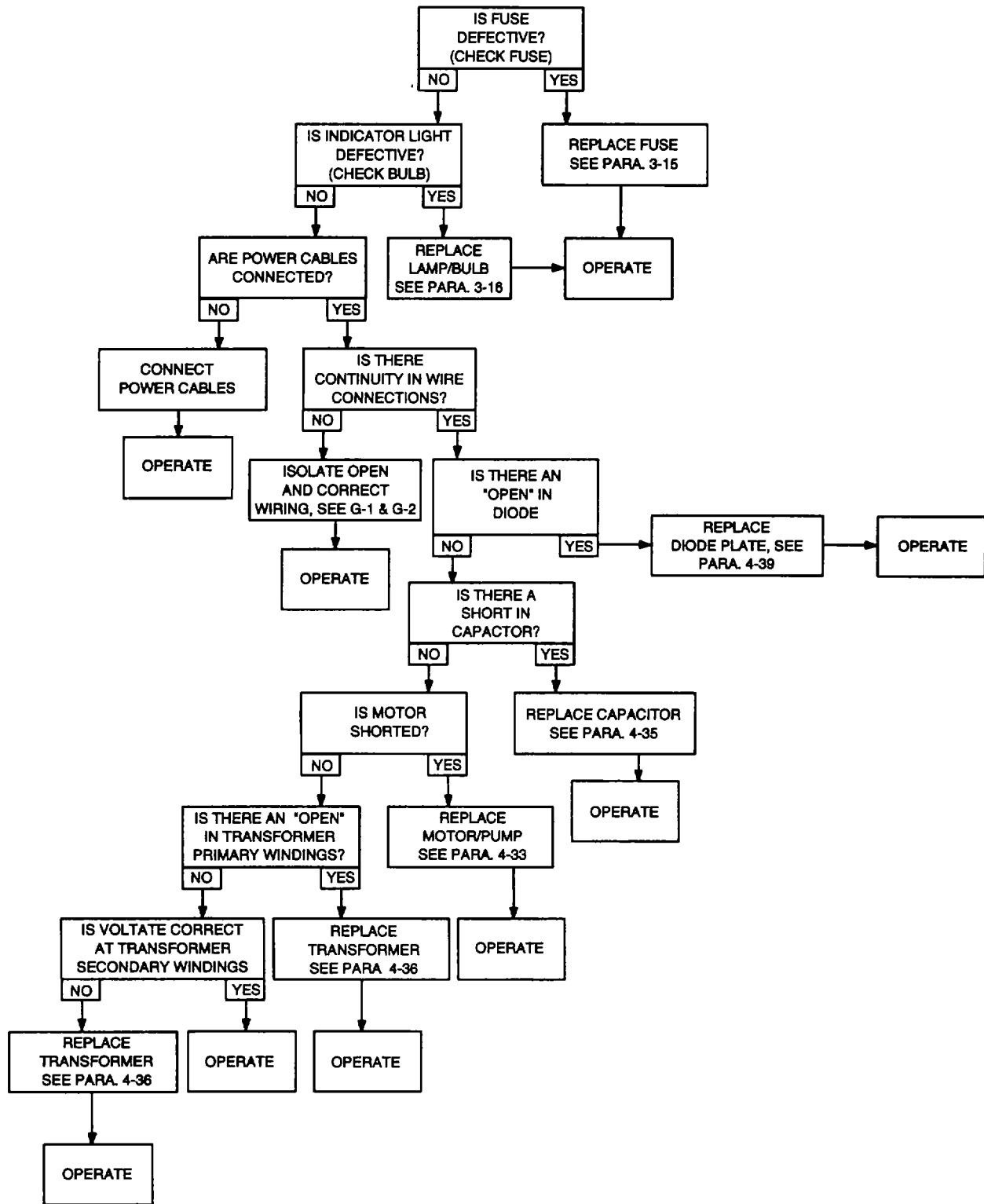

4-14. TROUBLESHOOTING PROCEDURE 2: TESTER DOES NOT BUILD OR HOLD PRESSURE (AIRSPEED/VACUUM ALTIMETER)

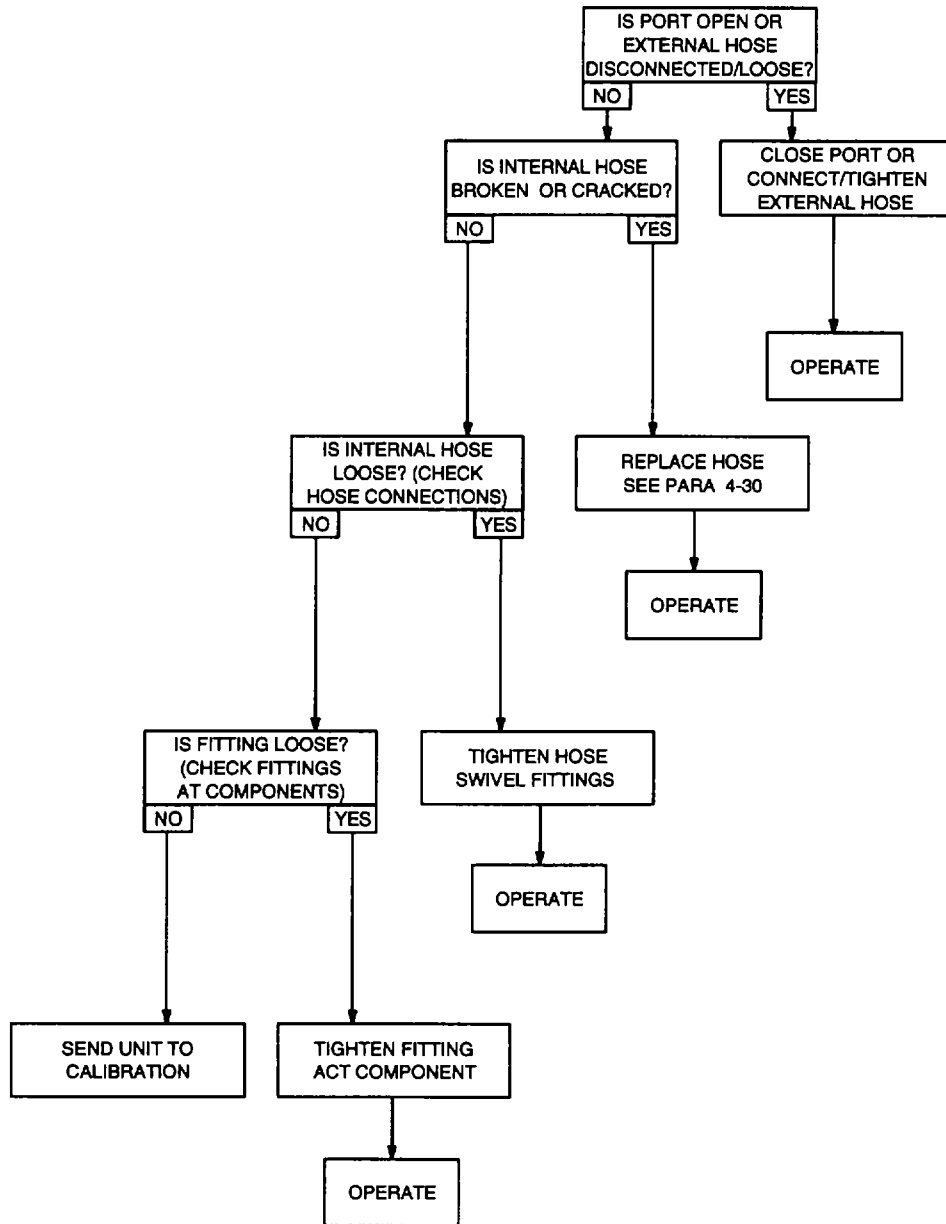

Section V. Maintenance Procedures

<u>SECTION CONTENTS</u>	<u>PARA</u>	<u>PAGE</u>
MAINTENANCE PROCEDURES - GENERAL	4-15	4-9
PITOT AND STATIC SYSTEMS TESTER CALIBRATION	4-16	4-9
REMOVE AND REPLACE RATE OF CLIMB INDICATOR	4-17	4-10
REMOVE AND REPLACE ALTIMETER	4-18	4-12
REMOVE AND REPLACE AIRSPEED INDICATOR	4-19	4-14
REMOVE AND REPLACE PRESSURE THREE WAY SELECTOR VALVE	4-20	4-16
REMOVE AND REPLACE RATE OF CLIMB TWO-WAY SHUT-OFF VALVE	4-21	4-18
REMOVE AND REPLACE ALTIMETER SHUT-OFF VALVE	4-22	4-20
REMOVE AND REPLACE AIRSPEED SHUT-OFF VALVE	4-23	4-22
REMOVE AND REPLACE VACUUM TWO-WAY SHUT-OFF VALVE	4-24	4-24
REMOVE AND REPLACE METERING VALVE (TYPICAL)	4-25	4-26
REMOVE AND REPLACE TOGGLE SWITCH	4-26	4-28
REMOVE AND REPLACE FUSE HOLDER	4-27	4-30
REMOVE AND REPLACE LIGHT ASSEMBLY	4-28	4-32
REMOVE AND REPLACE OVER PRESSURE RELIEF VALVE	4-29	4-34
REMOVE AND REPLACE HOSES AND FITTINGS (TYPICAL)	4-30	4-36
REMOVE AND REPLACE OIL SUMP (TYPICAL)	4-31	4-38
REMOVE AND REPLACE OIL FILTER	4-32	4-40
REMOVE AND REPLACE MOTOR/PUMP	4-33	4-42
REMOVE AND REPLACE PUMP AND/OR MOTOR ASSEMBLY	4-34	4-44
REMOVE AND REPLACE CAPACITOR	4-35	4-46
REMOVE AND REPLACE TRANSFORMER	4-36	4-48

<u>SECTION CONTENTS (CONT)</u>	<u>PARA</u>	<u>PAGE</u>
REMOVE AND REPLACE EMI FILTER	4-37	4-50
REMOVE AND REPLACE POWER CONNECTOR	4-38	4-52
REMOVE AND REPLACE DIODE PLATE	4-39	4-54
REPAIR WIRING HARNESS	4-40	4-56
REMOVE AND REPLACE OIL RESERVOIR AND/OR FILL AND RUN SELECTOR VALVE	4-41	4-58
REMOVE AND REPLACE RIGID PRESSURE LINES (TYPICAL)	4-42	4-60
REMOVE AND REPLACE CHECK VALVES	4-43	4-62
REMOVE AND REPLACE SOLENOID VALVES	4-44	4-64
REMOVE AND REPLACE BELLOWS	4-45	4-66

4-15. MAINTENANCE PROCEDURES - GENERAL

When a maintenance procedure is required, it usually will involve removal of the part being repaired or replaced. Removal procedures are given only to the extent necessary to repair or replace authorized parts. Fill panels are opened or removed using flat-tipped screwdriver and turning fasteners counterclockwise.

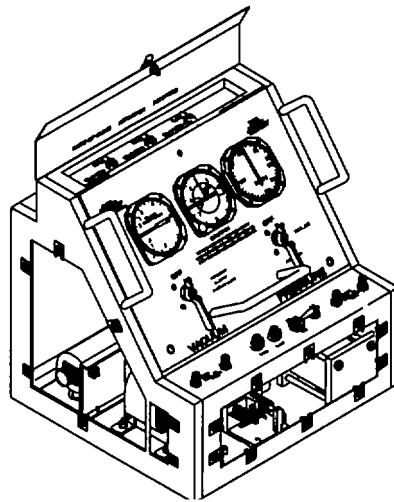

4-16. PITOT AND STATIC SYSTEMS TESTER CALIBRATION

Maintenance of the Pitot and Static Systems Tester consists of periodic recalibration. Calibration cannot be performed at AVIM level because a calibrated pressure/vacuum test gauge is required.

4-17. REMOVE AND REPLACE RATE OF CLIMB INDICATOR (Sheet 1 of 2)

Personnel Required:

35H Test, Measurement Diagnostic Equipment (TMDE) Support Specialist

Tools/Test and Support Equipment:

Tool Kit (B2) or Shop Set (B4)

Materials/Parts:

Rate of Climb Indicator
None

References:

TB 43-180

Equipment Conditions:

Power disconnected, valve cover panel open, control panel open (para. 4-15)

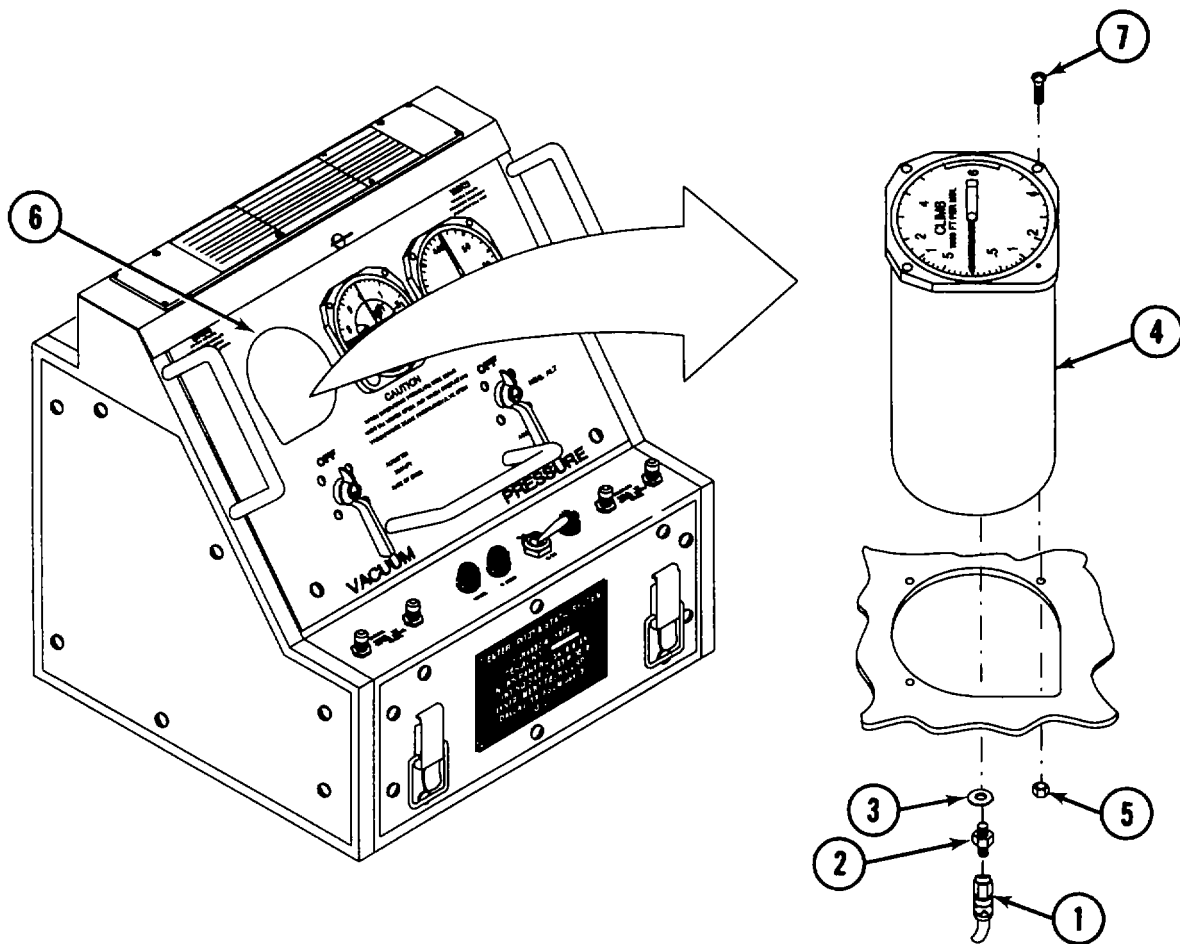

GO TO NEXT PAGE

4-17. REMOVE AND REPLACE RATE OF CLIMB INDICATOR (Cont) (Sheet 2 of 2)

4-17.1. REMOVAL

- a. Disconnect hose (1) and remove fitting (2) with preformed packing (3) from end of indicator (4).
- b. Remove three nuts (5) from underside of control panel (6).
- c. Remove three screws (7) securing indicator (4) to control panel (6).
- d. Remove indicator (4) from tester control panel (6).

4-17.2. INSTALLATION

- a. Install indicator (4) in control panel (6) and align mounting holes.
- b. Secure indicator (4) to control panel (6) with three screws (7) from outside control panel (6) and install three nuts (5).
- c. Install fitting (2) and connect hose (1) with preformed packing (3) to port at end of indicator (4).

4-17.3. FOLLOW ON MAINTENANCE

Calibration (TB 43-180)

Performance check (para. 2-5)

END OF TASK

4-18. REMOVE AND REPLACE ALTIMETER (Sheet 1 of 2)

Personnel Required: 35H TMDE Support Specialist

Tools/Test and Support Equipment: Tool kit (B2) or Shop Set (B4)

Materials/Parts: Altimeter, Sealube (D6)

References: TB 43-180

Equipment Conditions: Power disconnected, valve cover panel open, control panel open (para. 4-15)

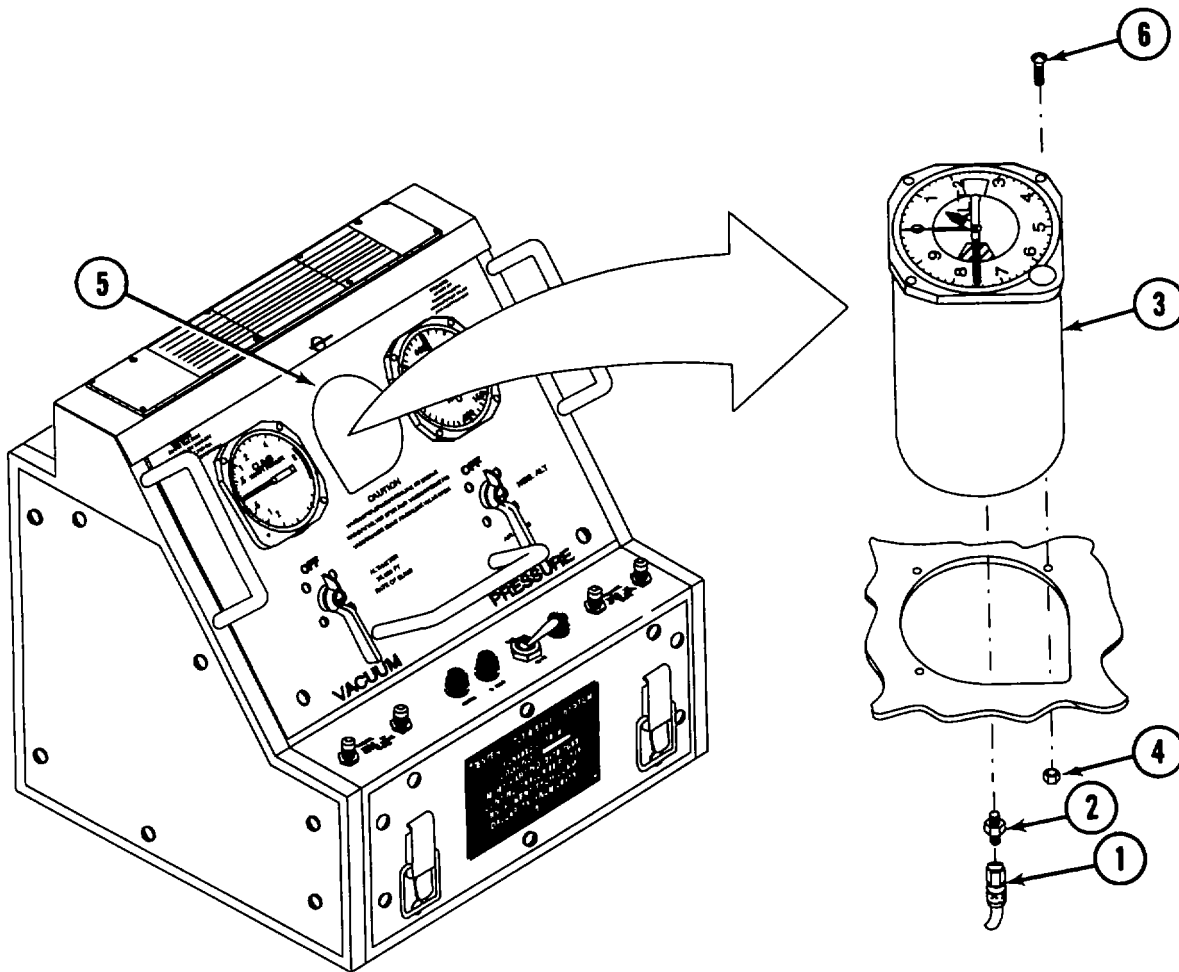

GO TO NEXT PAGE

4-18. REMOVE AND REPLACE ALTIMETER (Cont) (Sheet 2 of 2)

4-18.1. REMOVAL

- a. Disconnect hose (1) and remove fitting (2) from end of altimeter (3).
- b. Remove three nuts (4) from underside of tester control panel (5).
- c. Remove three screws (6) securing altimeter (3) to tester control panel (5).
- d. Remove altimeter (3) from tester control panel (5).

4-18.2. INSTALLATION

- a. Install altimeter (3) in tester control panel (5) and align mounting holes.
- b. Secure altimeter (3) to tester control panel (5) with three screws (6) from outside tester and install three nuts (4).
- c. Apply Sealube (D6) to fitting (2) threads.
- d. Install fitting (2) and connect hose (1) to port at end of altimeter (3).

4-18.3. FOLLOW ON MAINTENANCE

Calibration (TB 43-180)

Performance check (para. 2-5)

END OF TASK

4-19. REMOVE AND REPLACE AIRSPEED INDICATOR (Sheet I of 2)

Personnel Required: 35H TMDE Support Specialist

Tools/Test and Support Equipment: Tool kit (B2) or Shop Set (B4)

Materials/Parts: Altimeter, Sealube (D6)

References: TB 43-180

Equipment Conditions: Power disconnected, valve cover panel open, control panel open (para. 4-15)

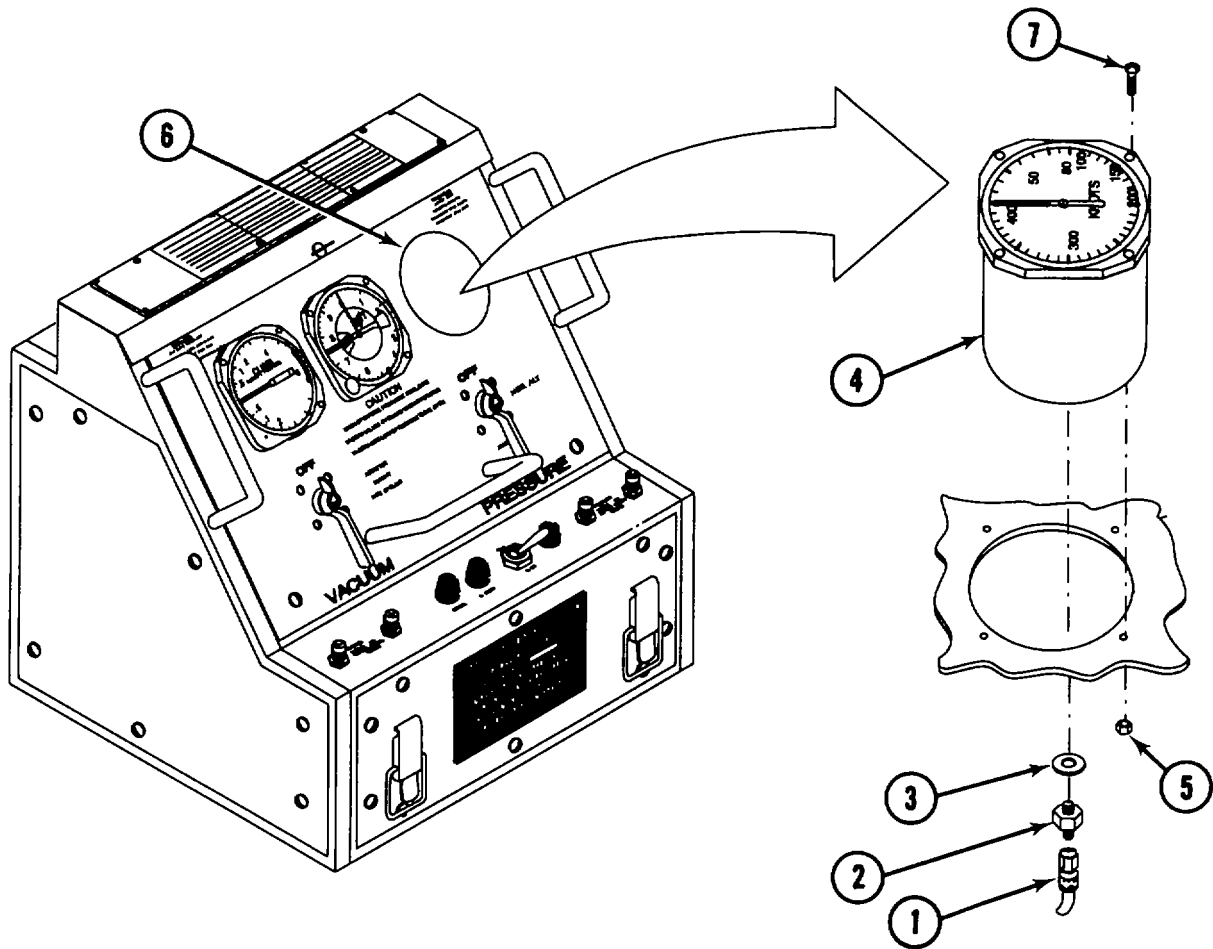

GO TO NEXT PAGE

4-19. REMOVE AND REPLACE AIRSPEED INDICATOR (Cont) (Sheet 2 of 2)

4-19.1. REMOVAL

- a. Disconnect hose (1) and remove fitting (2) with preformed packing (3) from end of airspeed indicator (4).
- b. Remove four nuts (5) from inside tester control panel (6).
- c. Remove four screws (7) securing airspeed indicator (4) from tester control panel (6).
- d. Remove airspeed indicator (4) from tester control panel (6).

4-19.2. INSTALLATION

- a. Install airspeed indicator (4) in tester control panel (6) and align mounting holes.
- b. Secure airspeed indicator (4) to tester control panel (6) with four screws (7) from outside tester control panel (6) and install four nuts (5).
- c. Install fitting (2) and connect hose (1) with preformed packing (3) to port at end of airspeed indicator (4).

4-19.3. FOLLOW ON MAINTENANCE

Calibration (TB 43-180)

Performance check (para. 2-5)

END OF TASK

4-20. REMOVE AND REPLACE PRESSURE THREE WAY SELECTOR VALVE (Sheet I of 2)

Personnel Required:

35H TMDE Support Specialist

Tools/Test and Support Equipment:

Tool Kit (B2) or Shop Set (B4)

Materials/Parts:

Selector valve, Sealube (D6)

Equipment Conditions:

Power disconnected, valve cover panel open, control panel open (para. 4-15)

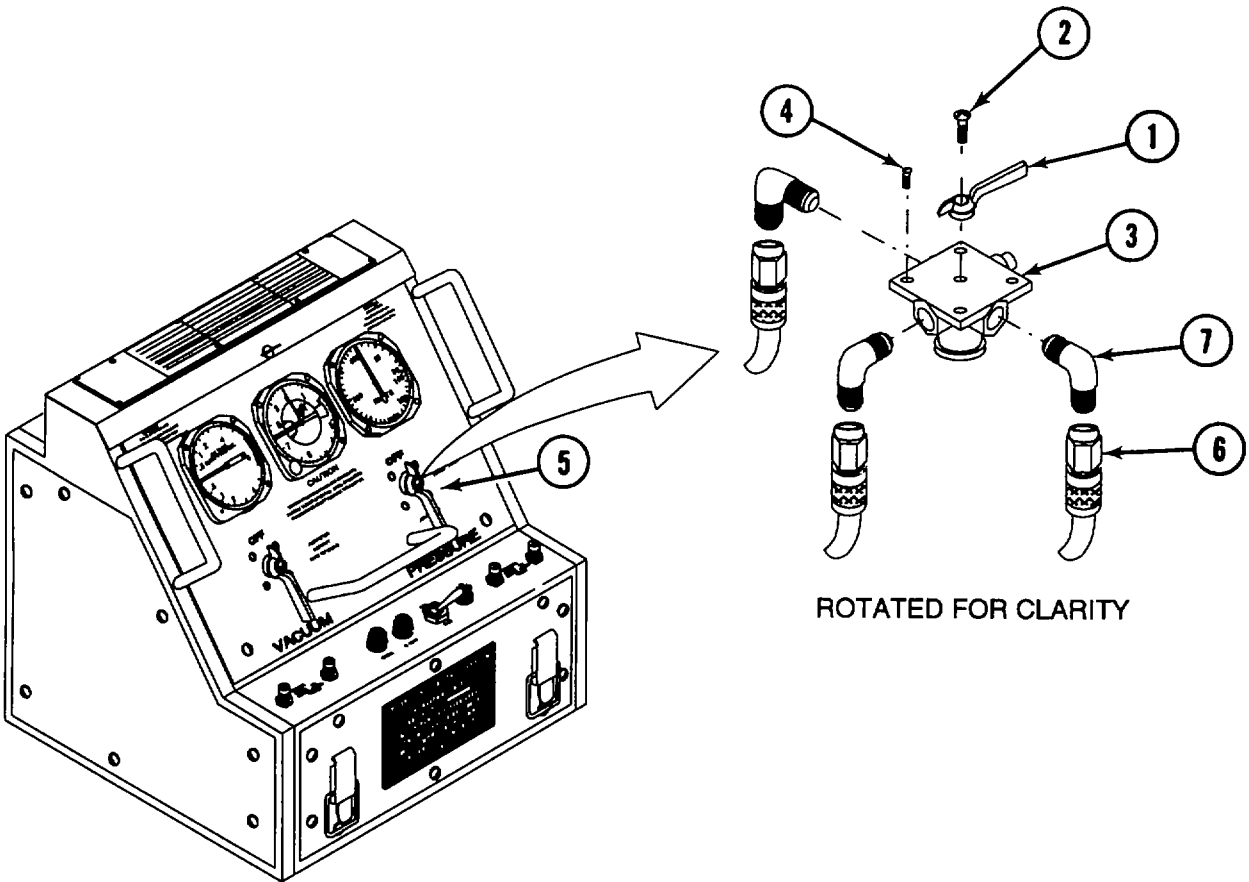

GO TO NEXT PAGE

4-20. REMOVE AND REPLACE PRESSURE THREE WAY SELECTOR VALVE (Cont) (Sheet 2 of 2)**4-20.1. REMOVAL**

- a. Position handle (1) to "OFF" position.
- b. Remove screw (2) from end of handle (1) and remove handle (1) from valve (3).

NOTE

Prior to removal of valve, note location of elbow fittings in relation to control panel.

- c. Remove four mounting screws (4) from tester control panel (5) and remove valve (3).
- d. Tag and disconnect three hoses (6) from elbow fittings (7).
- e. Remove three elbow fittings (7) from valve (3).

4-20.2. INSTALLATION

- a. Apply Sealube (D6) to three elbow fittings (7) before installing into valve (3).
- b. Install three elbow fittings (7) into valve (3).
- c. Connect three hoses (6) to elbow fittings (7) and remove tags.
- d. Position valve (3) into panel (5) and secure with four mounting screws (4).
- e. Place handle (1) on valve (3) and orient to "OFF" position.
- f. Install screw (2) through handle (1) to valve (3).

END OF TASK

4-21. REMOVE AND REPLACE RATE OF CLIMB TWO-WAY SHUT-OFF VALVE (Sheet 1 of 2)

Personnel Required:

35H TMDE Support Specialist

Tools/Test and Support Equipment:

Tool kit (B2) or Shop Set (B4)

Materials/Parts:

Shutoff valve, Sealube (D6)

Equipment Conditions:

Power disconnected, valve cover panel open, rear panel removed, control panel open (para. 4-15)

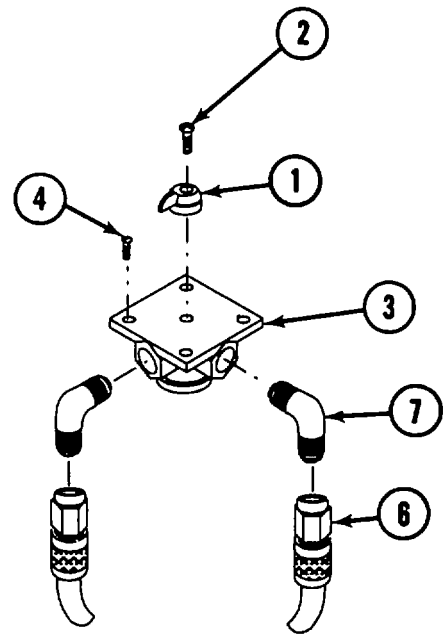
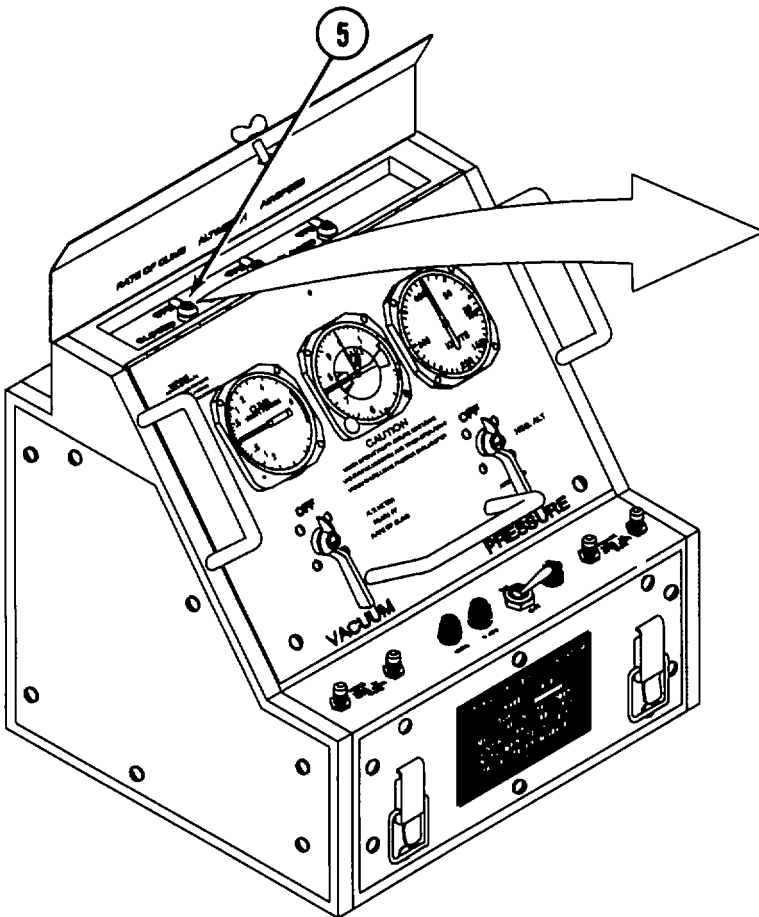

ROTATED FOR CLARITY

GO TO NEXT PAGE

4-21. REMOVE AND REPLACE RATE OF CLIMB TWO-WAY SHUT-OFF VALVE (Cont) (Sheet 2 of 2)

4-21.1. REMOVAL

- a. Position handle (1) to "OPEN" position.
- b. Remove screw (2) from end of handle (1) and remove handle (1) from valve (3).

NOTE

Prior to removal of valve, note location of elbow fittings in relation to control panel.

- c. Remove four mounting screws (4) from panel (5) and remove valve (3).
- d. Tag and disconnect two hoses (6) from fittings (7) on valve (3).
- e. Remove fittings (7) from valve (3).

4-21.2. INSTALLATION

- a. Apply Sealube (D6) to fittings (7) before installing into valve (3).
- b. Install fittings (7) on valve (3).
- c. Install two hoses (6) and remove tags.
- d. Position valve (3) into panel (5) and secure with four mounting screws (4).
- e. Place handle (1) on valve (3) and orient to "OPEN" position.
- f. Install screw (2) through handle (1) to valve (3).

4-21.3. FOLLOW ON MAINTENANCE

Performance check (para. 2-5)

END OF TASK

4-22. REMOVE AND REPLACE ALTIMETER SHUT-OFF VALVE (Sheet 1 of 2)

Personnel Required: 35H TMDE Support Specialist

Tools/Test and Support Equipment: Tool kit (B2) or Shop Set (B4)

Materials/Parts: Shut, off valve, Sealube (D6)

Equipment Conditions: Power disconnected, valve cover panel open, control panel open rear panel removed (para. 4-15)

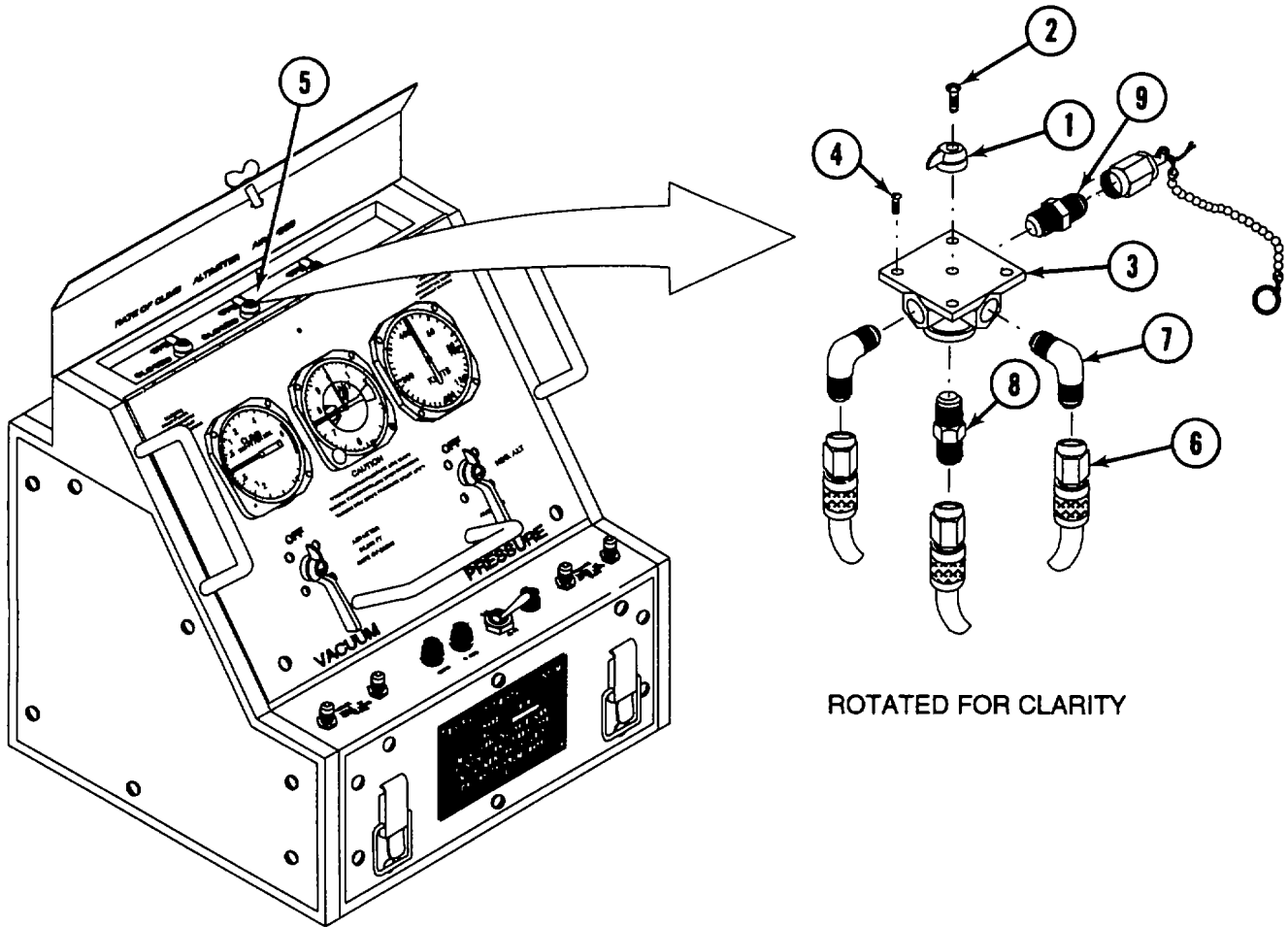

GO TO NEXT PAGE

4-22. REMOVE AND REPLACE ALTIMETER SHUT-OFF VALVE (Cont) (Sheet 2 of 2)**4-22.1. REMOVAL**

- a. Position handle (1) to "OPEN" position.
- b. Remove screw (2) from end of handle (1) and remove handle (1) from valve (3).

NOTE

Prior to removal of valve, note location of elbow fittings in relation to control panel.

- c. Remove four mounting screws (4) from panel (5) and remove valve (3) from panel (5).
- d. Tag and disconnect three hoses (6) from fittings (7 and 8).
- e. Remove four fittings (7, 8 and 9) from valve (3).

4-22.2. INSTALLATION

- a. Apply Sealube (D6) to four fittings (7, 8 and 9) before installing into valve (3).
- b. Install four fittings (7, 8 and 9) into valve (3).
- c. Install three hoses (6) to fittings (7 and 8) before mounting valve (3) and remove tags.
- d. Position valve (3) into panel (5) and secure with four mounting screws (4).
- e. Place handle (1) on valve (3) and orient to "OPEN" position.
- f. Install screw (2) through handle (1) to valve (3).

4-22.3. FOLLOW ON MAINTENANCE

Performance check (para. 2-5)

END OF TASK

4-23. REMOVE AND REPLACE AIRSPEED SHUT-OFF VALVE (Sheet 1 of 2)

Personnel Required:

35H, Calibration and Repair Specialist

Tools/Test and Support Equipment:

Tool Kit (B2) or Shop Set (B4)

Materials/Parts:

Airspeed shut-off valve, Sealube (D6)

Equipment Conditions:

Power disconnected, valve cover panel open, control panel open, rear panel removed (para. 4-15)

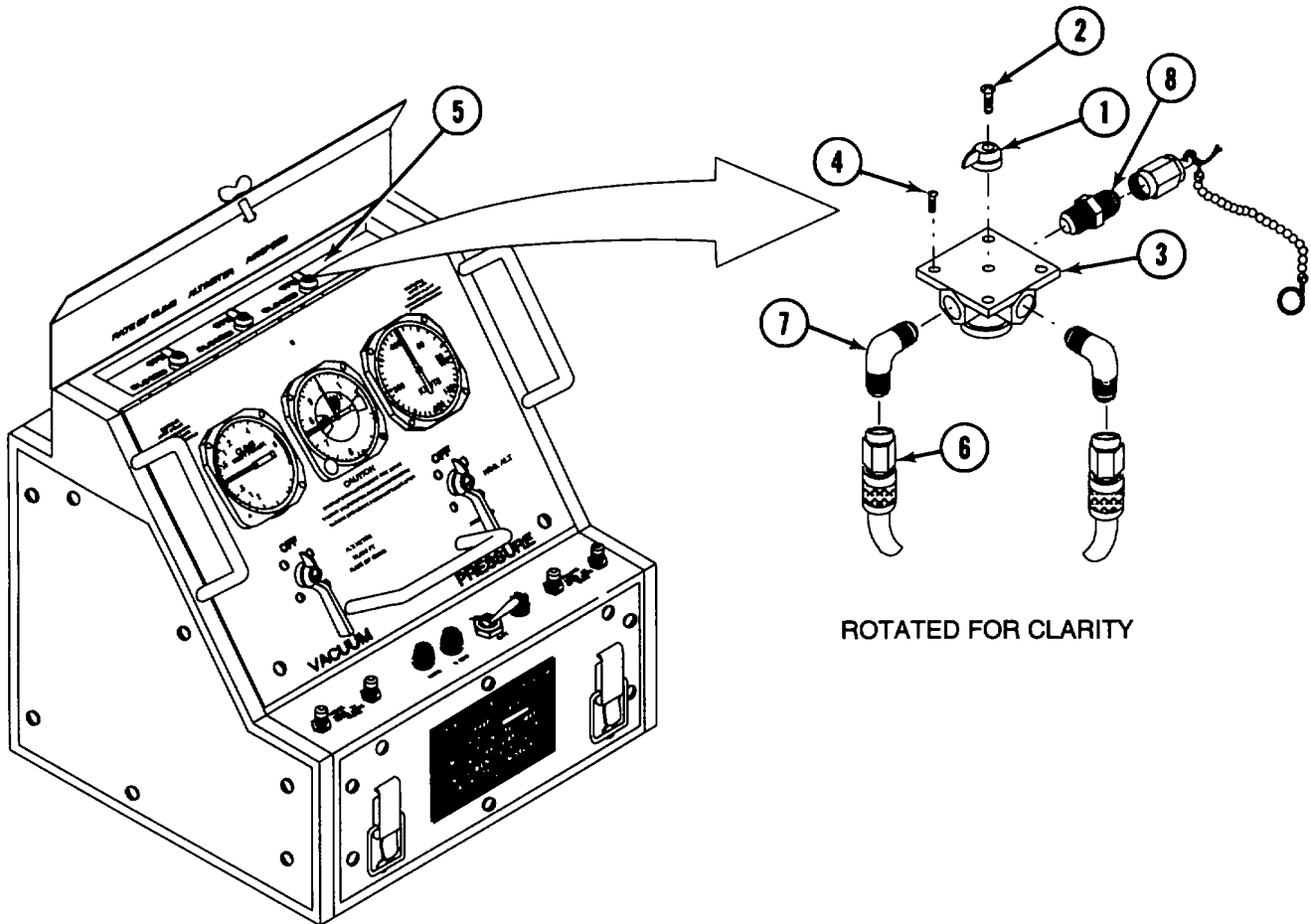

GO TO NEXT PAGE

**4-23. REMOVE AND REPLACE AIRSPEED SHUT-OFF VALVE (Cont)
(Sheet 2 of 2)****4-23.1. REMOVAL**

- a. Position handle (1) to "OPEN" position.
- b. Remove screw (2) from end of handle (1) and remove handle (1) from valve (3).

NOTE

Prior to removal of valve, note location of elbow fittings in relation to control panel.

- c. Remove four mounting screws (4) from panel (5) and remove valve (3).
- d. Tag and disconnect two hoses (6) from elbow fittings (7).
- e. Remove two elbow fittings (7) from valve (3).
- f. Remove fitting (8) from valve (3).

4-23.2. INSTALLATION

- a. Apply Sealube (D6) to three fittings (7 and 8) before installing into valve (3).
- b. Install two elbow fittings (7) and fitting (8) into valve (3).
- c. Install two hoses (6) to elbow fittings (7) and remove tags.
- d. Position valve (3) into panel (5) and secure with four mounting screws (4).
- e. Place handle (1) on valve (3) and orient to "OPEN" position.
- f. Install screw (2) through handle (1) to valve (3).

4-23.3. FOLLOW ON MAINTENANCE

Performance check (para. 2-5)

END OF TASK

4-24. REMOVE AND REPLACE VACUUM TWO-WAY SHUT-OFF VALVE
(Sheet 1 of 2)

Personnel Required:

Tools/Test and Support Equipment:

Materials/Parts:

Equipment Conditions:

35H TMDE Support Specialist

Tool Kit (B2) or Shop Set (B4)

Shut off valve, Sealube (D6)

Power disconnected, valve cover panel open (para. 4-15)

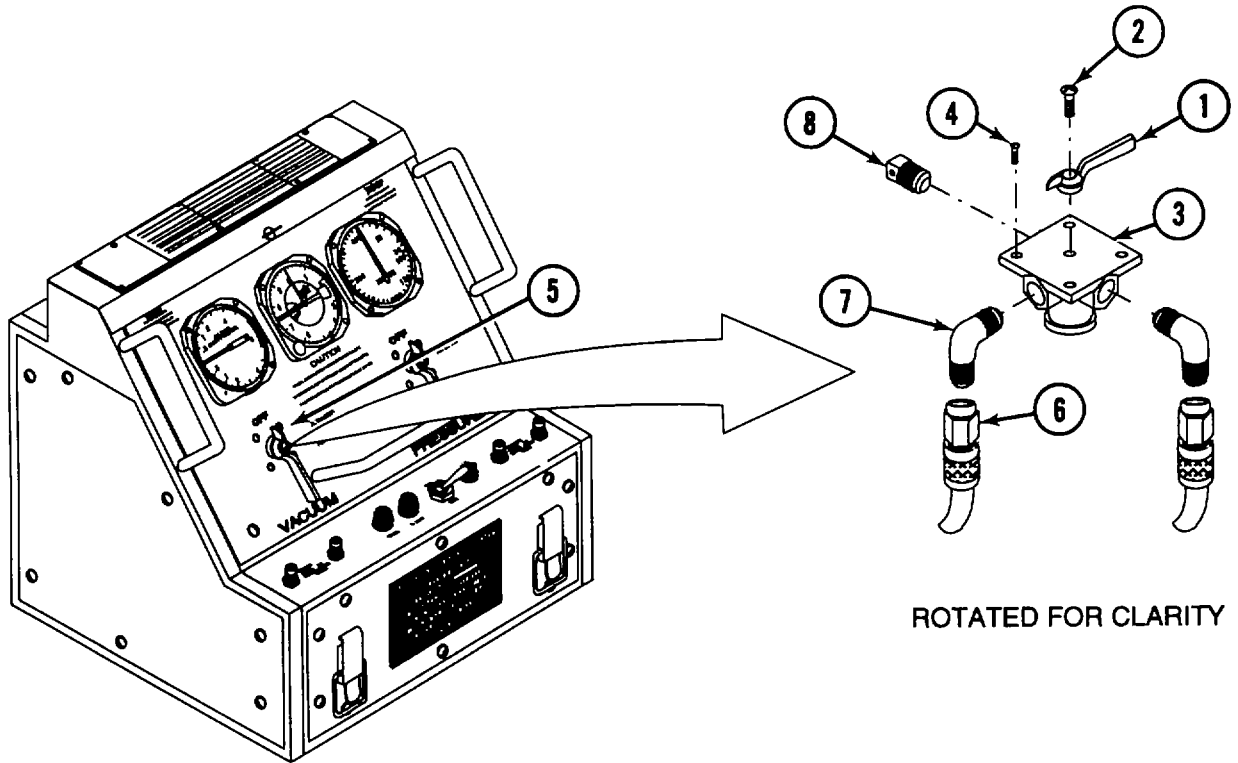

GO TO NEXT PAGE

4-24. REMOVE AND REPLACE VACUUM TWO-WAY SHUT-OFF VALVE (Cont)
(Sheet 2 of 2)**4-24.1. REMOVAL**

- a. Position handle (1) to "OFF" position.
- b. Remove screw (2) from end of handle (1) and remove handle (1) from valve (3).

NOTE

Prior to removal of valve, note location of elbow fittings in relation to control panel.

- c. Remove four mounting screws (4) from panel (5) and remove valve (3) from panel (5).
- d. Tag and disconnect two hoses (6) from fittings (7) on valve (3).
- e. Remove two fittings (7) and plug (8) from valve (3).

4-24.2. INSTALLATION

- a. Apply Sealube (D6) to fittings (7) and plug (8) before installing into valve (3).
- b. Install two fittings (7) and plug (8) to valve (3).
- c. Connect two hoses (6) to fittings (7) and remove tags.
- d. Position valve (3) into panel (5) and secure with four mounting screws (4).
- e. Place handle (1) on valve (3) and orient to "OFF" position.
- f. Install screw (2) through handle (1) to valve (3).

4-24.3. FOLLOW ON MAINTENANCE

Performance check (para. 2-5)

END OF TASK

4-25. REMOVE AND REPLACE METERING VALVES (TYPICAL)
(Sheet 1 of 2)

Personnel Required:

Tools/Test and Support Equipment:

Materials/Parts:

Equipment Conditions:

35H TMDE Support Specialist

Tool Kit (B2) or Shop Set (B4)

Metering valve, Sealube (D6)

Power disconnected, front panel and right
panel removed (para. 4-15)

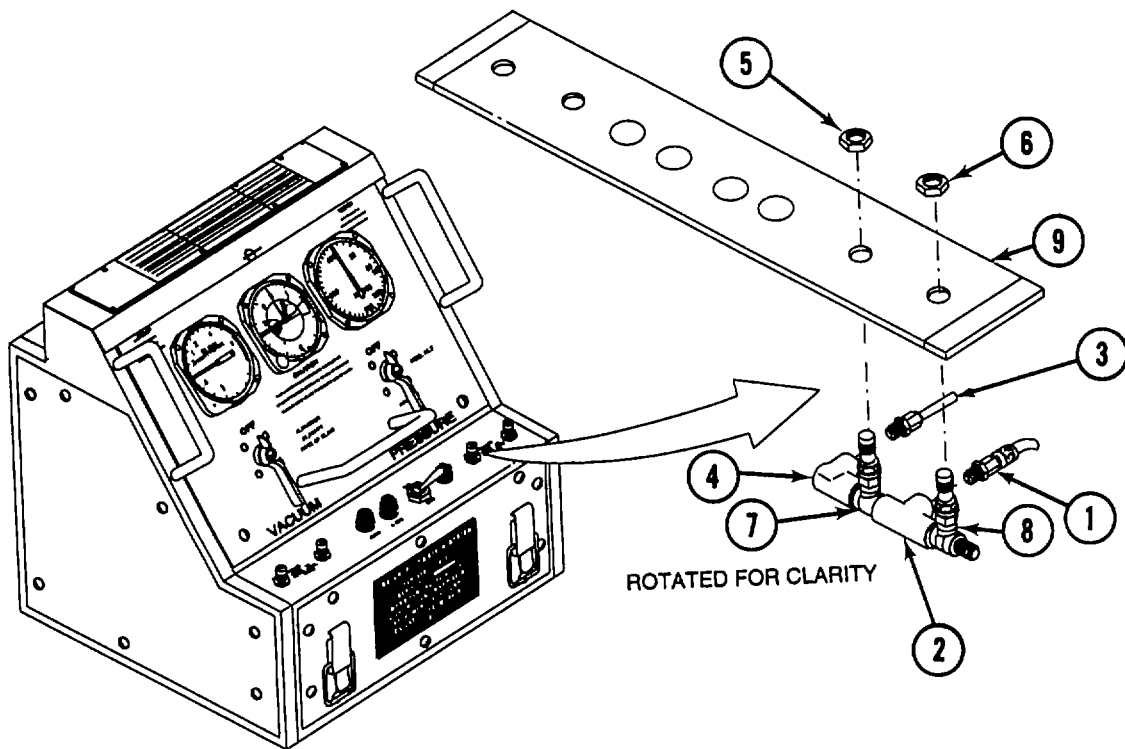

GO TO NEXT PAGE

4-25. REMOVE AND REPLACE METERING VALVES (TYPICAL) (Cont)
(Sheet 2 of 2)

4-25.1. REMOVAL

- a. Disconnect hose (1) from fitting (2) and rigid pipe (3) from fitting (4).
- b. Remove panel mounting nuts (5 and 6) and remove metering valves (7 and 8) from control panel (9).
- c. Remove fittings (2 and 4) from metering valves (7 and 8).

4-25.2. INSTALLATION

- a. Apply Sealube (D6) to fittings (2 and 4).
- b. Install fittings (2 and 4) to metering valves (7 and 8).
- c. Place metering valves in holes in control panel (9) and secure with panel mounting nuts (5 and 6).
- d. Attach hose (1) to fitting (2) and rigid pipe (3) to fitting (4).

4-25.3. FOLLOW ON MAINTENANCE

Performance check (para. 2-5)

END OF TASK

4-26. REMOVE AND REPLACE TOGGLE SWITCH
(Sheet 1 of 2)

Personnel Required:

Tools/Test and Support Equipment:

Materials/Parts:

Equipment Conditions:

35H TMDE Support Specialist

Tool Kit (B2) or Shop Set (B4)

Toggle Switch

Power disconnected, front panel removed
(para. 4-15)

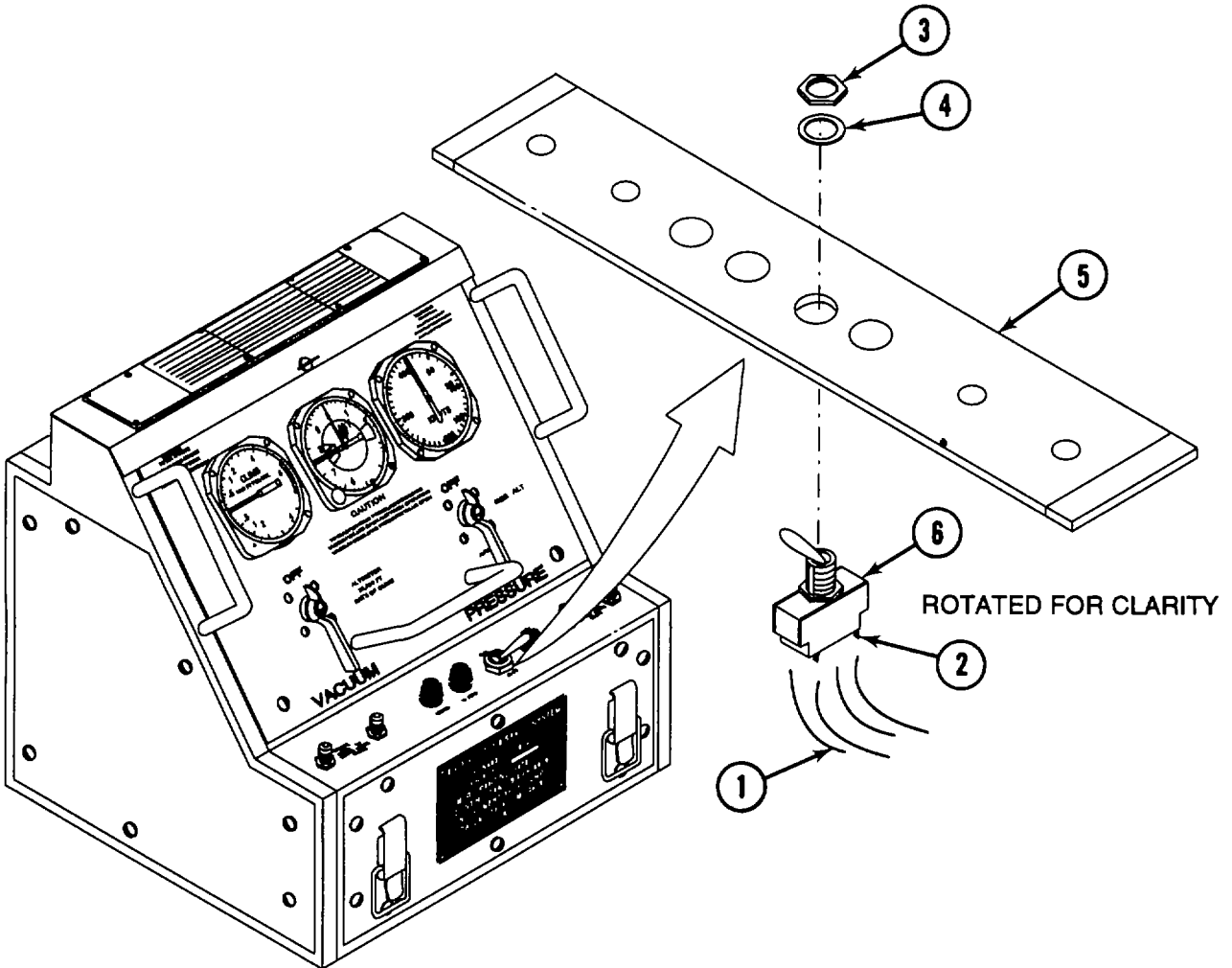

GO TO NEXT PAGE

4-26. REMOVE AND REPLACE TOGGLE SWITCH (Cont)
(Sheet 2 of 2)

4-26.1. REMOVAL

- a. Tag and remove four wires (1) from switch leads (2).
- b. Remove mounting nut (3) and washer (4) from top of operator panel (5).
- c. Remove switch (6) from the bottom of the operator panel (5).

4-26.2. INSTALLATION

- a. Mount switch (6) into operator panel (5) from the bottom up using mounting nut (3) and washer (4).
- b. Attach four wires (1) to switch leads (2) and remove tags.

4-26.3. FOLLOW ON MAINTENANCE

Performance check (para. 2-5)

END OF TASK

4-27. REMOVE AND REPLACE FUSE HOLDER
(Sheet 1 of 2)

Personnel Required:

Tools/Test and Support Equipment:

Materials/Parts:

Equipment Conditions:

35H TMDE Support Specialist

Tool kit (B2) or Shop Set (B4)

Fuse holder, solder (D5)

Power disconnected, front panel removed
(para. 4-15)

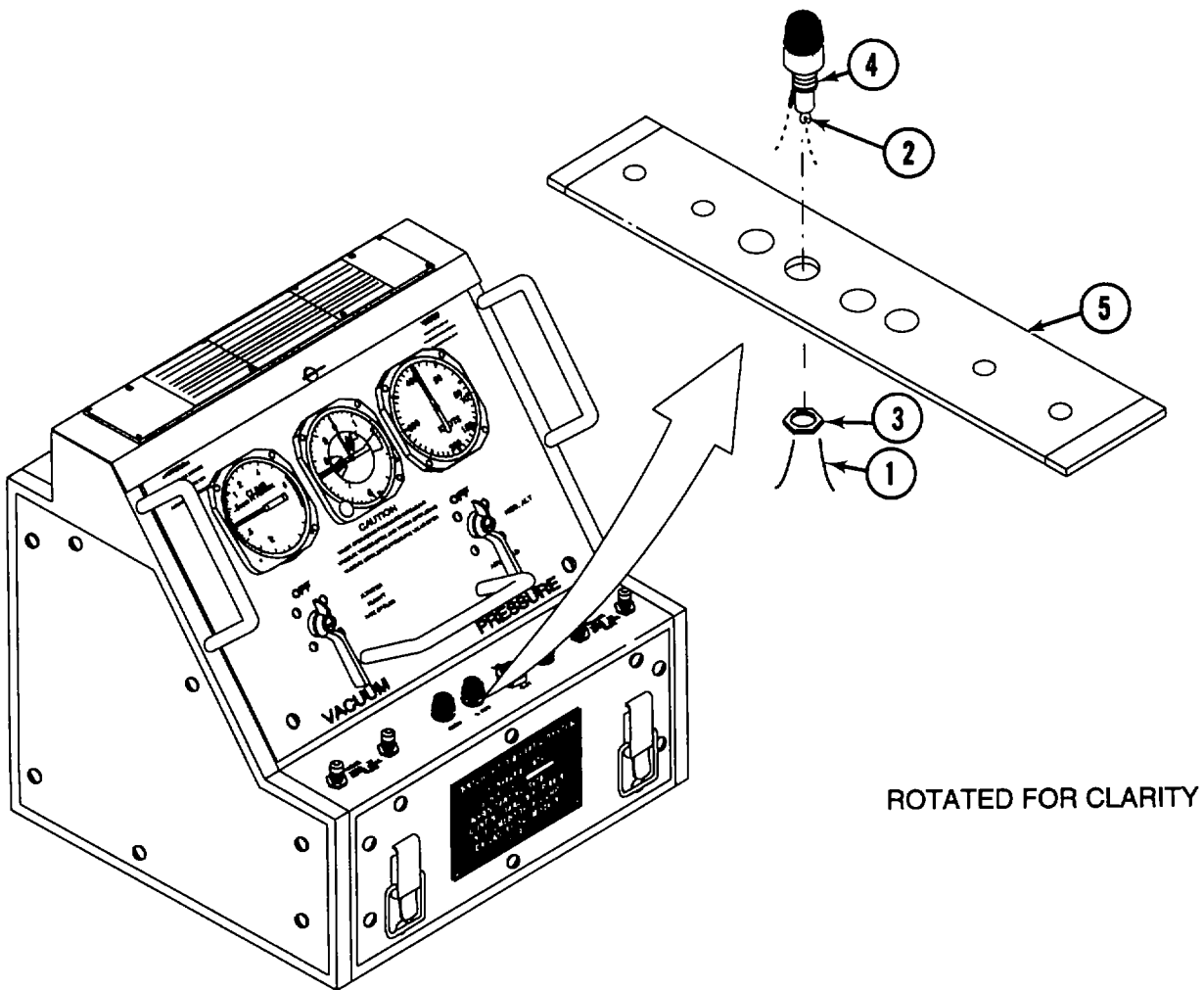

ROTATED FOR CLARITY

GO TO NEXT PAGE

4-27. REMOVE AND REPLACE FUSE HOLDER (Cont)
(Sheet 2 of 2)

4-27.1. REMOVAL

- a. Unsolder two wires (1) from fuse holder leads (2).
- b. Remove mounting nut (3) from fuse holder (4) on bottom side of operator panel (5).
- c. Remove fuse holder (4) from top of operator panel (5).

4-27.2. INSTALLATION

- a. Mount fuse holder (4) from top of operator panel (5).
- b. Secure fuse holder (4) to operator panel (5) by installing mounting nut (3) on bottom side of operator panel (5).
- c. Solder two wires (1) to fuse holder leads (2) using solder (D5).

4-27.3. FOLLOW ON MAINTENANCE

Performance check (para. 2-5)

END OF TASK

4-28. REMOVE AND REPLACE LIGHT ASSEMBLY
(Sheet 1 of 2)

Personnel Required:

Tools/Test and Support Equipment:

Materials/Parts:

Equipment Conditions:

35H TMDE Support Specialist

Tool kit (B2) or Shop Set (B4)

Light assembly, Pilot lamp bulb,

Solder (D5)

Power disconnected, front panel removed

(para. 4-15)

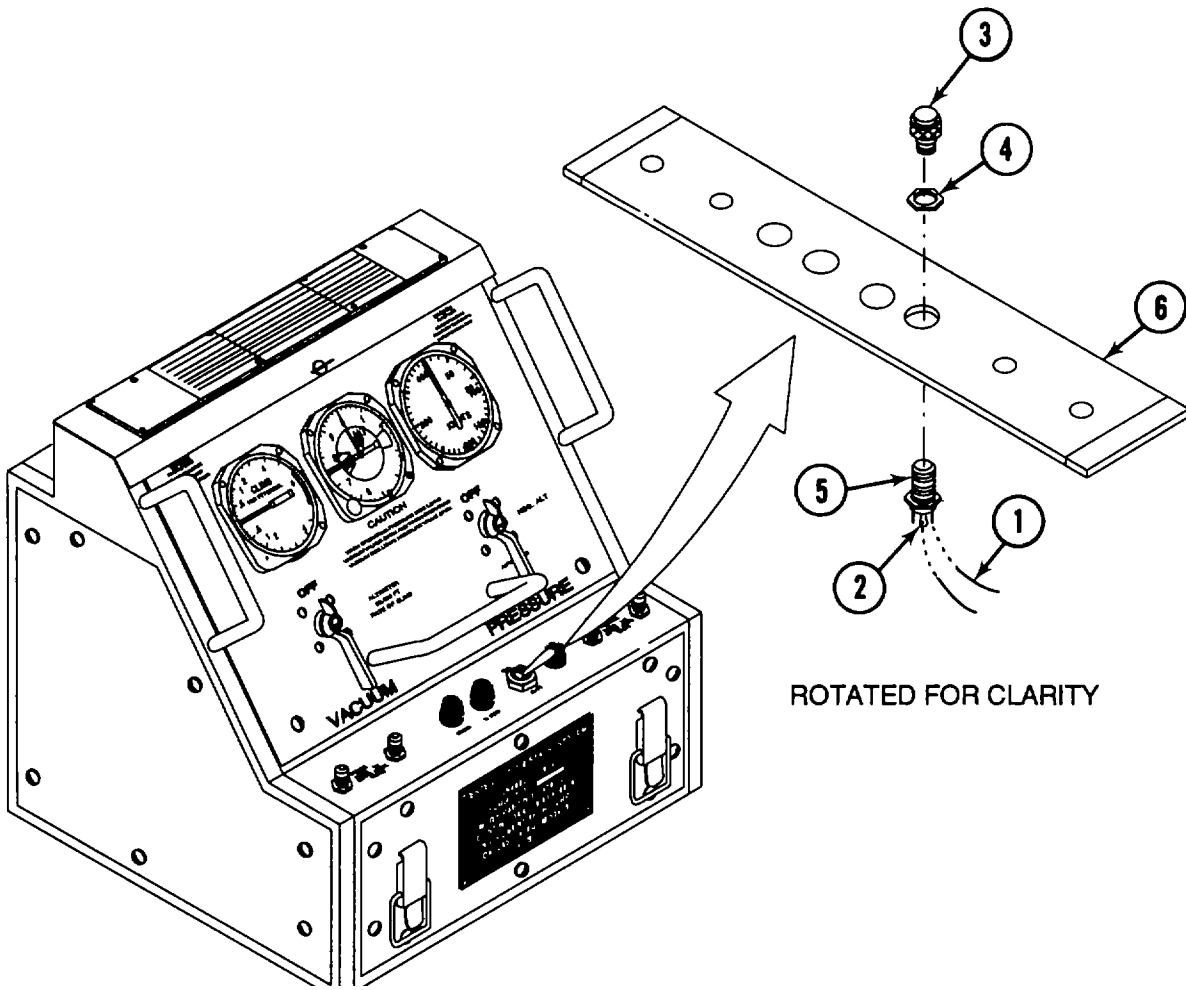

4-28. REMOVE AND REPLACE LIGHT ASSEMBLY (Cont)
(Sheet 2 of 2)

4-28.1. REMOVAL

- a. Tag and unsolder two wires (1) from light assembly leads (2).
- b. Remove pilot lamp (3) by turning it counterclockwise.
- c. Remove mounting nuts (4) from light assembly (5) and remove light assembly (5) from operator panel (6).

4-28.2. INSTALLATION

- a. Turn pilot lamp (3) clockwise into light assembly (5) and hand tighten.
- b. Install light assembly (5) into operator panel (6) and secure with mounting nuts (4).
- c. Solder two wires (1) to light assembly leads (2) using solder (D5).

4-28.3. FOLLOW ON MAINTENANCE

Performance check (para. 2-5)

END OF TASK

4-29. REMOVE AND REPLACE OVER PRESSURE RELIEF VALVE
(Sheet 1 of 2)

Personnel Required:

Tools/Test and Support Equipment:

Materials/Parts:

Equipment Conditions:

35H TMDE Support Specialist

Tool kit (B2) or Shop Set (B4)

Filter, Sealube (D6)

Power disconnected, back panel removed,
right panel removed (para. 4-15)

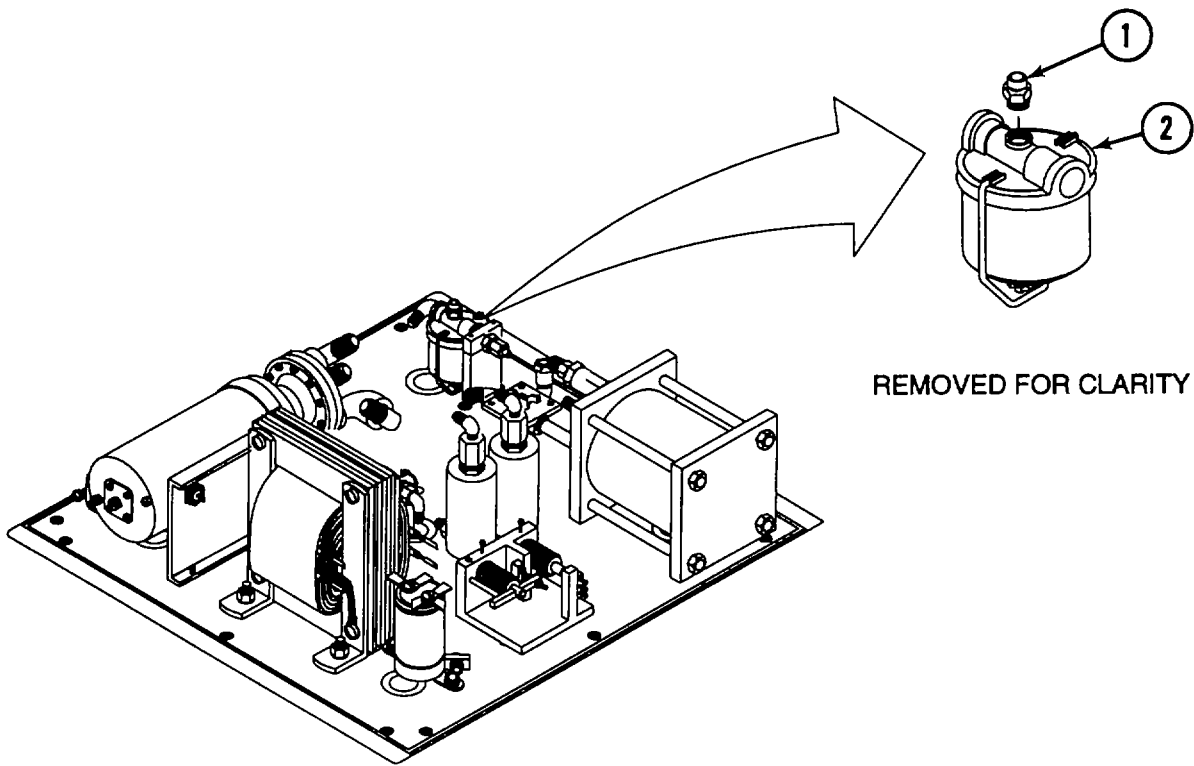

GO TO NEXT PAGE

4-29. REMOVE AND REPLACE OVER PRESSURE RELIEF VALVE (Cont)
(Sheet 2 of 2)

4-29.1. REMOVAL

Remove over pressure relief valve (1) from oil sump (2), by turning over pressure relief valve (1) counterclockwise.

4-29.2. INSTALLATION

- a. Apply Sealube (D6) to over pressure relief valve (1).
- b. Install over pressure relief valve (1) onto oil sump (2) by turning over pressure relief valve (1) clockwise.

4-29.3. FOLLOW ON MAINTENANCE

Performance check (para. 2-5)

END OF TASK

4-30. REMOVE AND REPLACE HOSES AND FITTINGS (TYPICAL)
(Sheet 1 of 2)

Personnel Required:

Tools/Test and Support Equipment:

Materials/Parts:

Equipment Conditions:

35H TMDE Support Specialist

Tool Kit (B2) or Shop Set (B4)

Hoses and fittings, Sealube (D6)

Power disconnected, valve cover panel open, control panel open, back panel, right and left panel removed (para 4-15)

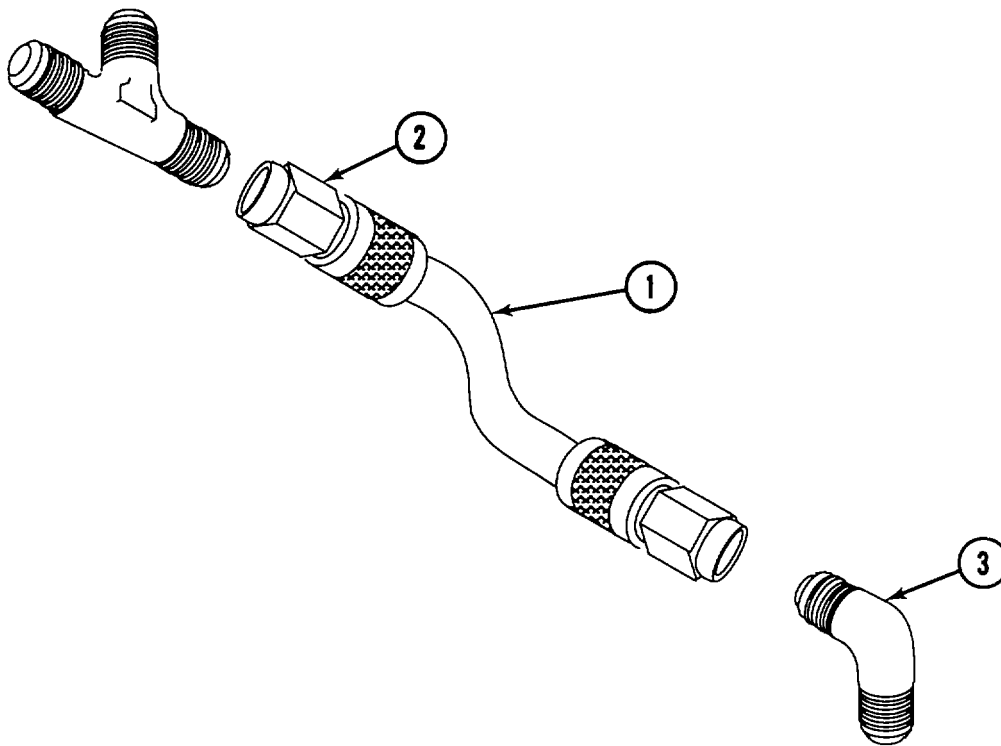

GO TO NEXT PAGE

4-30. REMOVE AND REPLACE HOSES AND FITTINGS (TYPICAL) (Cont)
(Sheet 2 of 2)

4-30.1. REMOVAL

- a. Tag and remove hoses (1) by turning swivel nut (2) on each end counter-clockwise.
- b. Remove fittings (3) by turning counterclockwise.

4-30.2. INSTALLATION



Ensure hoses and fittings are clean and free of foreign material to avoid contamination to the instrument indicating system.

- a. Install fittings (3) by turning clockwise.
- b. Install hoses (1) by turning swivel nut (2) on both ends of hose clockwise.

4-30.3. FOLLOW ON MAINTENANCE

Performance check (para 2-5)

END OF TASK

4-31. REMOVE AND REPLACE OIL SUMP (TYPICAL)
 (Sheet 1 of 2)

Personnel Required:

Tools/Test and Support Equipment:

Materials/Parts:

Equipment Conditions:

35H TMDE Support Specialist

Tool Kit (B2) or Shop Set (B4)

Oil Sump, Sealube (D6)

Power disconnected, valve cover panel open, control panel open, and left, right, and rear panel removed (para. 4-15)

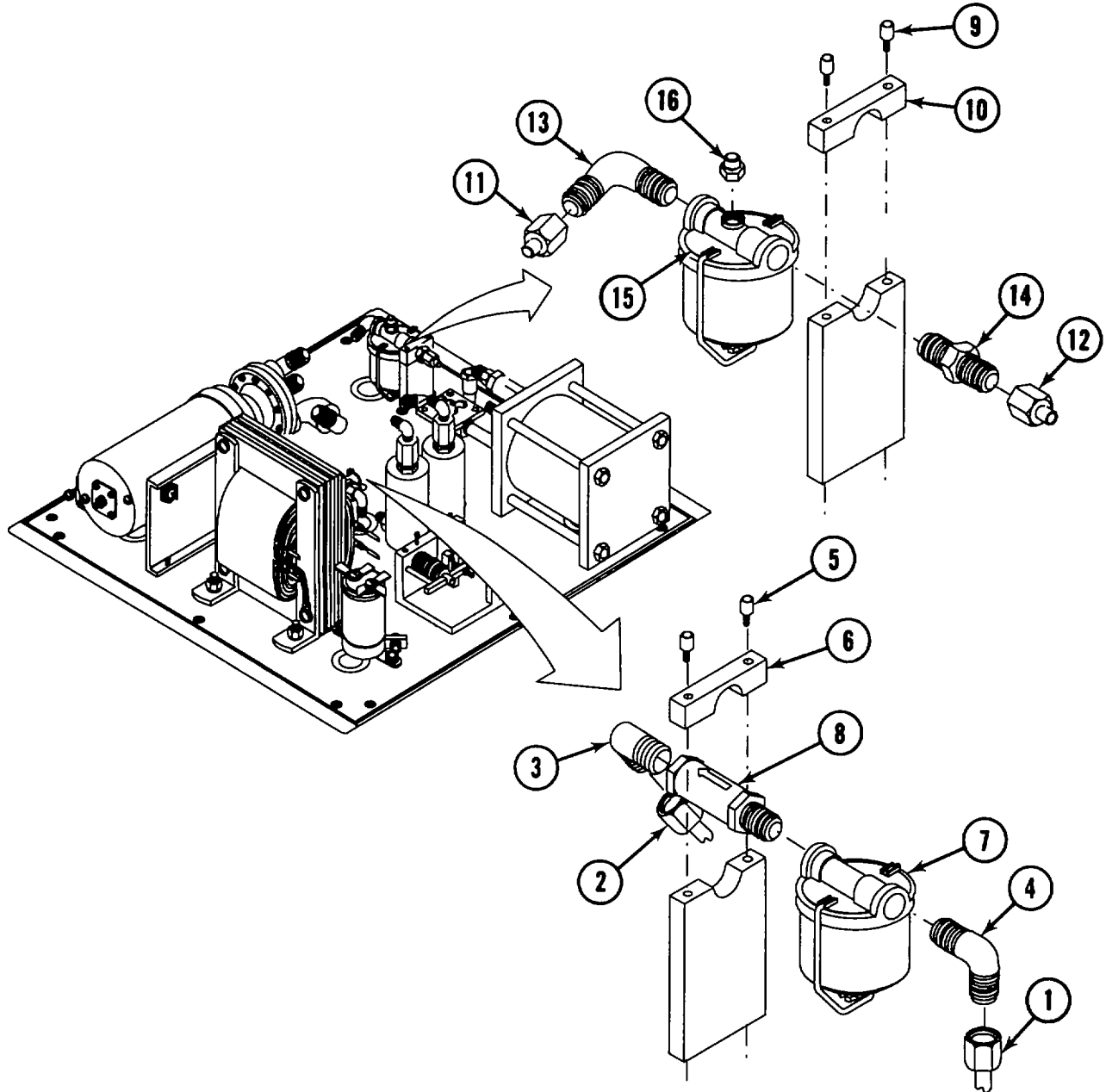

GO TO NEXT PAGE

4-31. REMOVE AND REPLACE OIL SUMP (TYPICAL) (Cont)
(Sheet 2 of 2)

4-31.1. REMOVAL

- a. Disconnect rigid pressure lines (1 and 2) from fittings (3 and 4).
- b. Remove two screws (5) from support bracket (6) and remove bracket (6).
- c. Remove oil sump (7) and remove elbow fitting (4) and check valve (8).
- d. Remove two screws (9) from support bracket (10) and remove bracket (10).
- e. Disconnect rigid pressure lines (11 and 12) from fittings (13 and 14).
- f. Remove oil sump (7) and remove elbow fitting (13) and fitting (14).
- g. Remove pressure relief valve (16) from oil sump (15).

4-31.2. INSTALLATION

- a. Apply Sealube (D6) to all fitting threads and install pressure relief valve (16) and elbow fitting (13) to inlet, and fitting (14) to outlet on oil sump (15).
- b. Connect rigid pressure lines (11 and 12) on fittings (13 and 14).
- c. Install oil sump (15) with bracket (10) using two screws (9).
- d. Install elbow fitting (4) to outlet on oil sump (7).

NOTE

Ensure check valve arrow is pointed to rear of test set when installed.

- e. Install elbow fitting (3) and check valve (8) on oil sump (7).
- f. Install oil sump (7) with support bracket (6) and secure with two screws (5).
- g. Connect rigid pressure lines (1 and 2) to fittings (3 and 4).

4-31.3. FOLLOW ON MAINTENANCE

Performance check (para. 2-5)

END OF TASK

4-32. REMOVE AND REPLACE OIL FILTER
(Sheet 1 of 2)

Personnel Required:

Tools/Test and Support Equipment:

Materials/Parts:

Equipment Conditions:

35H TMDE Support Specialist

Tool Kit (B2) or Shop Set (B4)

Filter

Power disconnected, valve cover panel open, control panel open, back panel, left and right panel removed (para. 4-15)

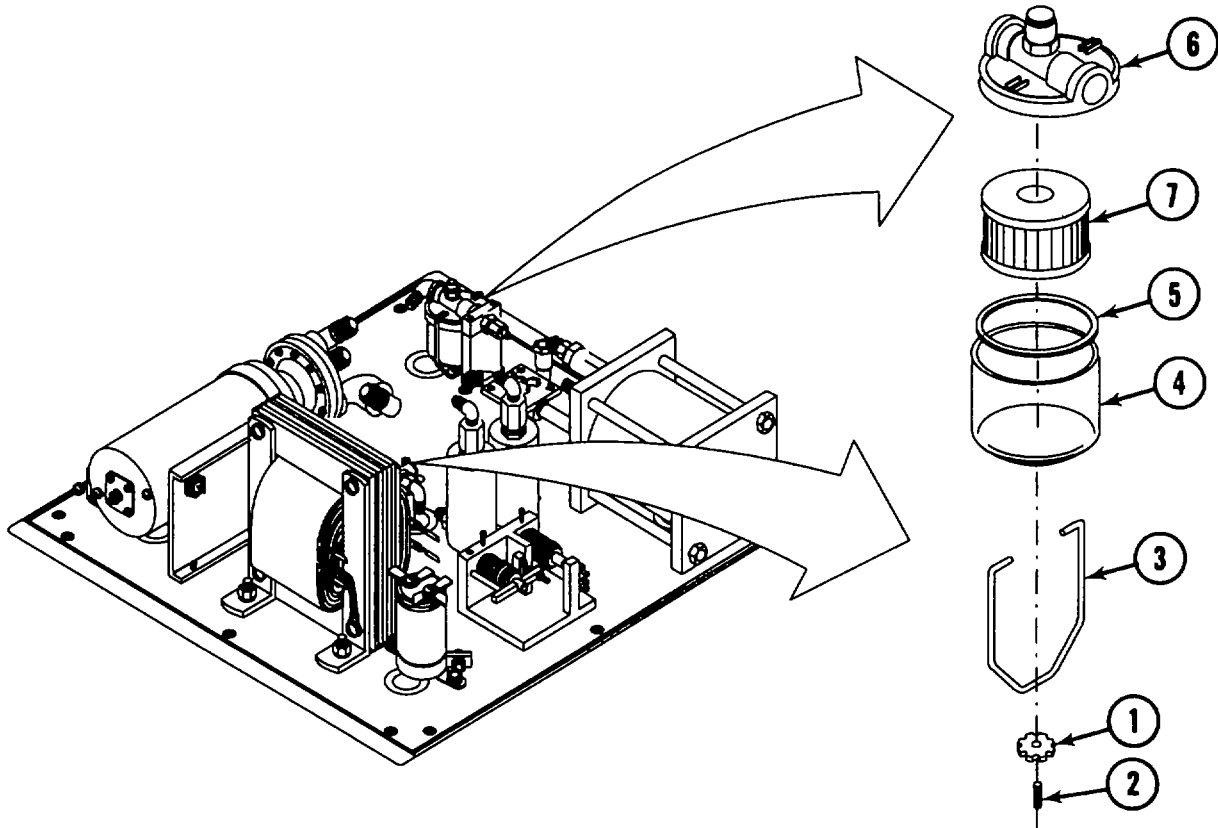

TYPICAL 2 PLACES

GO TO NEXT PAGE

4-32. REMOVE AND REPLACE OIL FILTER (Cont)
(Sheet 2 of 2)

4-32.1. REMOVAL

- a. Remove oil sump (task 4-31).
- b. Loosen star nut (1) and screw (2) by turning counterclockwise.
- c. Swing retainer wire (3) away from bowl (4).
- d. Remove bowl (4) and rubber gasket (5) from housing (6).
- e. Remove filter (7) from housing (6).

4-32.2. INSTALLATION

- a. Install filter (7) into housing (6).
- b. Install rubber gasket (5) on housing (6).
- c. Install bowl (4) on housing (6).
- d. Swing retainer wire (3) under bowl (4) and adjust star nut (1) and screw (2) to tighten.
- e. Install oil sump per task 4-31.

4-32.3. FOLLOW ON MAINTENANCE

Performance check (para. 2-5)

END OF TASK

**4-33. REMOVE AND REPLACE MOTOR/PUMP
(Sheet 1 of 2)**

Personnel Required:

Tools/Test and Support Equipment:

Materials/Parts:

Equipment Conditions:

35H TMDE Support Specialist

Tool Kit (B2) or Shop Set (B4)

Motor/Pump, Sealube (D6)

Power disconnected, back panel removed
(para. 4-15)

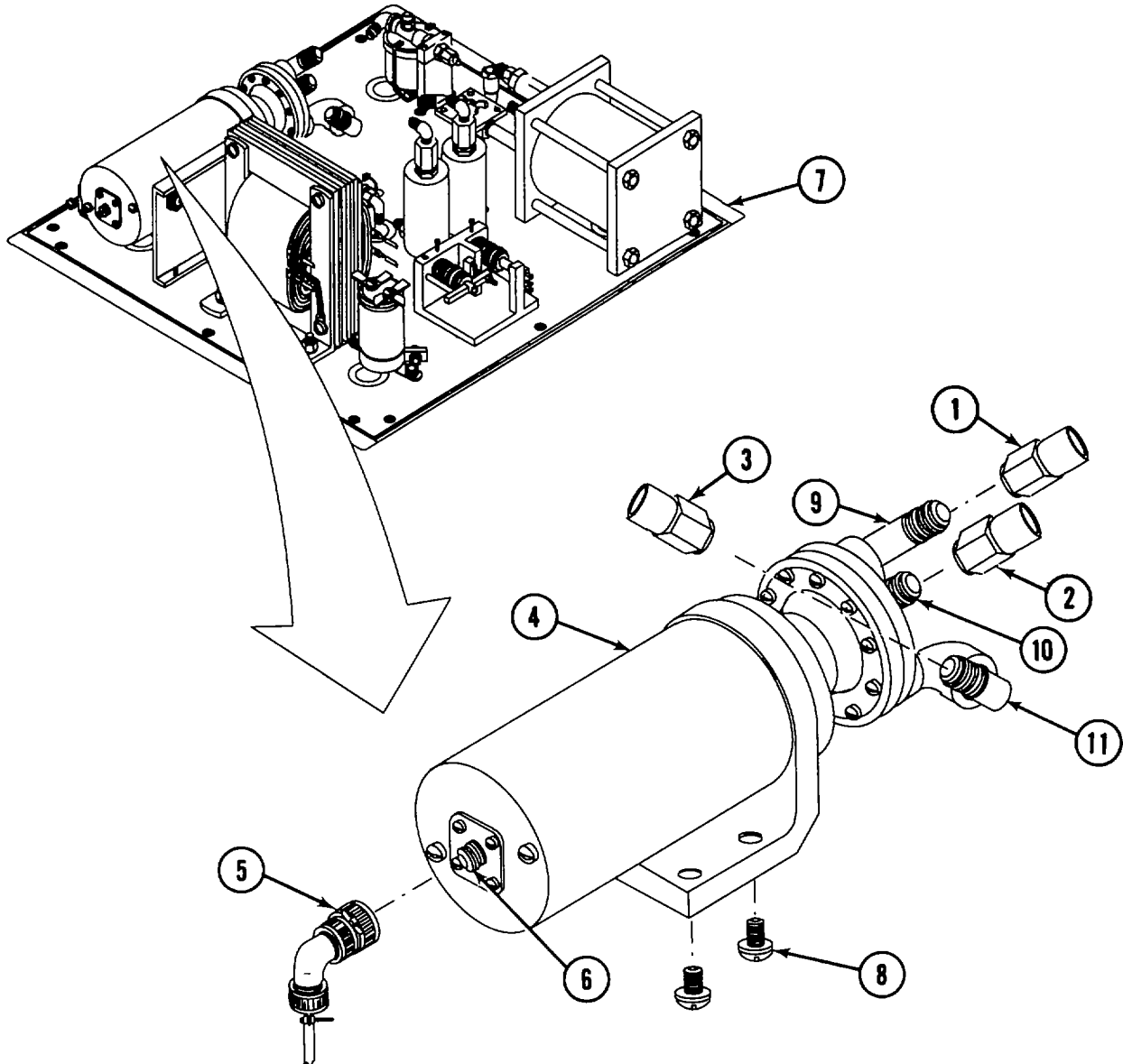

GO TO NEXT PAGE

**4-33. REMOVE AND REPLACE MOTOR/PUMP (Cont)
(Sheet 2 of 2)****4-33.1. REMOVAL**

- a. Disconnect rigid pressure lines (1,2, & 3) from motor/pump (4).
- b. Disconnect connector (5) from motor receptacle (6) by turning counter-clockwise.
- c. Tip chassis (7) forward and remove four screws (8) from bottom chassis (7).
- d. Remove motor/pump (4).
- e. Remove fittings (9, 10 and 11)) from motor/pump (4).

4-33.2. INSTALLATION

- a. Apply Sealube (D6) on all threads of fittings (9, 10 and 11).
- b. Install fittings (9, 10 and 11) on motor/pump (4).
- c. Position motor/pump (4) over mounting holes in chassis (7) and secure with four screws (8) through bottom of chassis (7).
- d. Connect the connector (5) to the motor receptacle (6) by rotating clockwise until connector (5) is hand tight.
- e. Reconnect rigid pressure lines (1,2, & 3) to their respective ports.

4-33.3. FOLLOW ON MAINTENANCE

Performance check (para. 2-5)

END OF TASK

4-34. REMOVE AND REPLACE PUMP AND/OR MOTOR ASSEMBLY
(Sheet 1 of 2)

Personnel Required:

Tools/Test and Support Equipment:

Materials/Parts:

Equipment Conditions:

35H TMDE Support Specialist

Tool Kit (B2 or Shop Set (B4)

Pump Assembly

Power disconnected, hoses and fittings removed (para. 4-33), and back panel removed (para. 4-15)

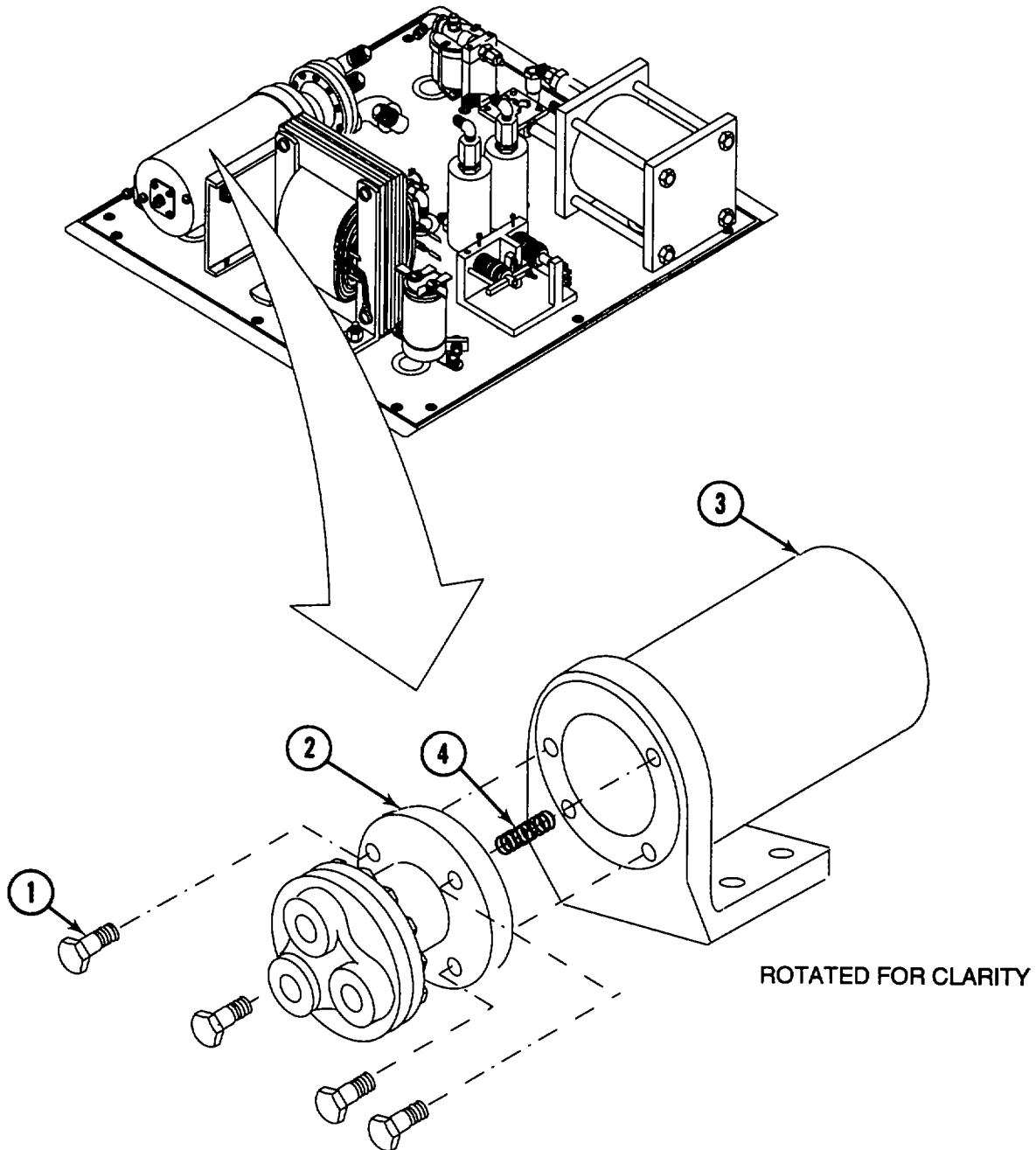

GO TO NEXT PAGE

4-34. REMOVE AND REPLACE PUMP AND/OR MOTOR ASSEMBLY (Cont)
(Sheet 2 of 2)

4-34.1. REMOVAL

- a. Remove four screws (1) from pump assembly (2).
- b. Remove pump assembly (2) from electric motor (3).

4-34.2. INSTALLATION

NOTE

Spring (4) must be installed in pump (2) before assembly.

- a. Install pump assembly (2) on electric motor (3) with oil and air outlets at bottom.
- b. Install four screws (1).

4-34.3. FOLLOW ON MAINTENANCE

Performance check (para. 2-5)

END OF TASK

4-35. REMOVE AND REPLACE CAPACITOR
(Sheet 1 of 2)

Personnel Required:

Tools/Test and Support Equipment:

Materials/Parts:

Equipment Conditions:

35H TMDE Support Specialist

Tool kit (B2) or Shop set (B4)

Capacitor

Power disconnected, valve cover panel open, front and left panels removed, control panel open (para. 4-15)

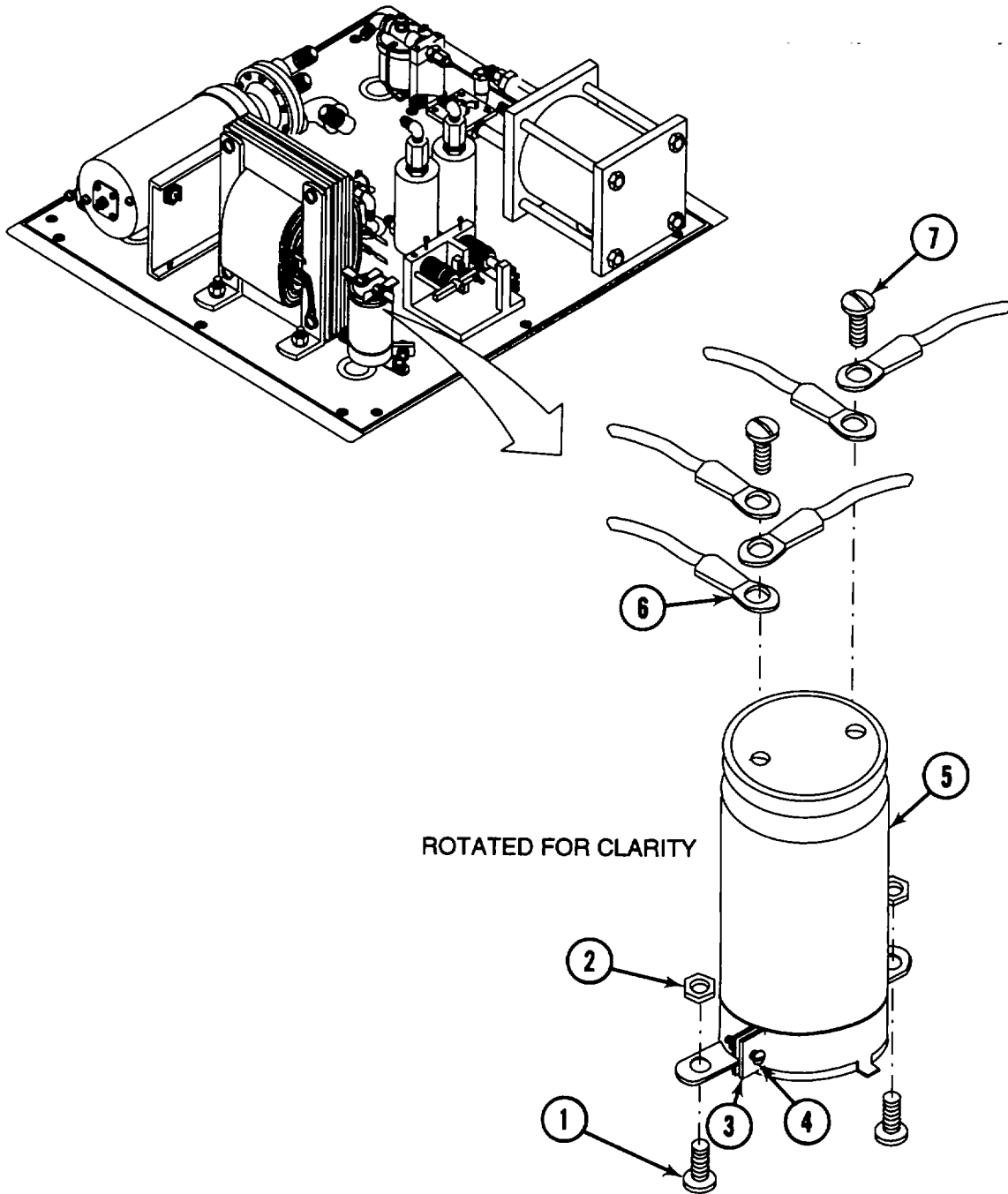

GO TO NEXT PAGE

4-35. REMOVE AND REPLACE CAPACITOR (Cont)
(Sheet 2 of 2)

4-35.1. REMOVAL

- a. Remove front screw (1) and nut (2) from front of capacitor clamp (3).
- b. Rotate capacitor clamp (3) to access capacitor clamp screw (4).
- c. Loosen capacitor clamp screw (4) from capacitor clamp (3) and remove capacitor (5) from clamp (3).
- d. Tag and remove five wire connectors (6) from capacitor (5) by removing two screws (7). Install screws (7) back into capacitor (5).
- e. Remove capacitor (5).

4-35.2. INSTALLATION

- a. Remove two screws (7) from new capacitor (5), and connect five wire connectors (6) to capacitor (5).
- b. Install capacitor (5) into capacitor clamp (3) and tighten clamp screw (4) to hold capacitor (5).
- c. Remove tags from five wire connectors (6).
- d. Rotate clamp (3) and align.
- e. Install screw (1) with nut (2).

4-35.3. FOLLOW ON MAINTENANCE

Performance check (para. 2-5)

END OF TASK

4-36. REMOVE AND REPLACE TRANSFORMER
(Sheet 1 of 2)

Personnel Required:

Tools/Test and Support Equipment:

Materials/Parts:

Equipment Conditions:

35H TMDE Support Specialist

Tool Kit (B2) or Shop Set (B4)

Transformer, Solder (D5)

Power disconnected, left side removed,
front panel removed (para. 4-15)

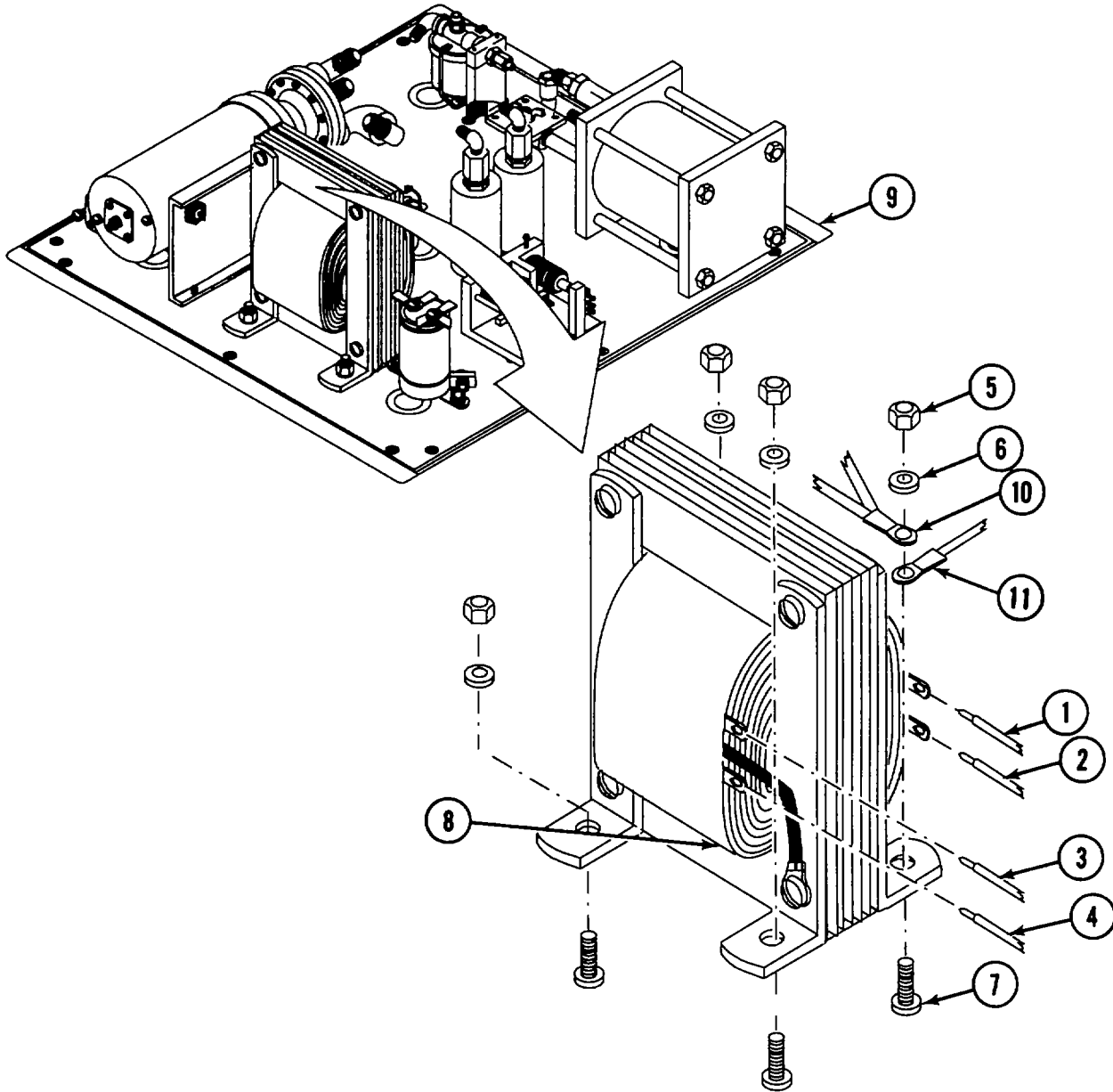

GO TO NEXT PAGE

**4-36. REMOVE AND REPLACE TRANSFORMER (Cont)
(Sheet 2 of 2)**

4-36.1. REMOVAL

- a. Tag and unsolder wires (1, 2, 3 and 4) from transformer leads.
- b. Remove four nuts (5) and four flat washers (6) from screws (7) holding transformer (8) to the base of chassis (9).
- c. Remove two wire connectors (10 and 11).
- d. Remove transformer (8) from base of chassis (9).

4-36.2. INSTALLATION

- a. Install transformer (8) on screws (7).
- b. Install two wire connectors (10 and 11).
- c. Secure transformer (8) to base of chassis (9) with four flat washers (6) and four nuts (5) on screws (7).
- d. Solder four wires (1, 2, 3 and 4) to leads of transformer (8) using solder (D5) and remove tags.

4-36.3. FOLLOW ON MAINTENANCE

Performance check (para. 2-5)

END OF TASK

4-37. REMOVE AND REPLACE EMI FILTER
 (Sheet 1 of 2)

Personnel Required:

Tools/Test and Support Equipment:

Materials/Parts:

Equipment Conditions:

35H TMDE Support Specialist

Tool kit (B2) or Shop Set (B4)

EMI Filter, Heat Shrink (D2), Solder (D5)

Power disconnected, valve cover panel open, left & rear panels removed (para. 4-15)

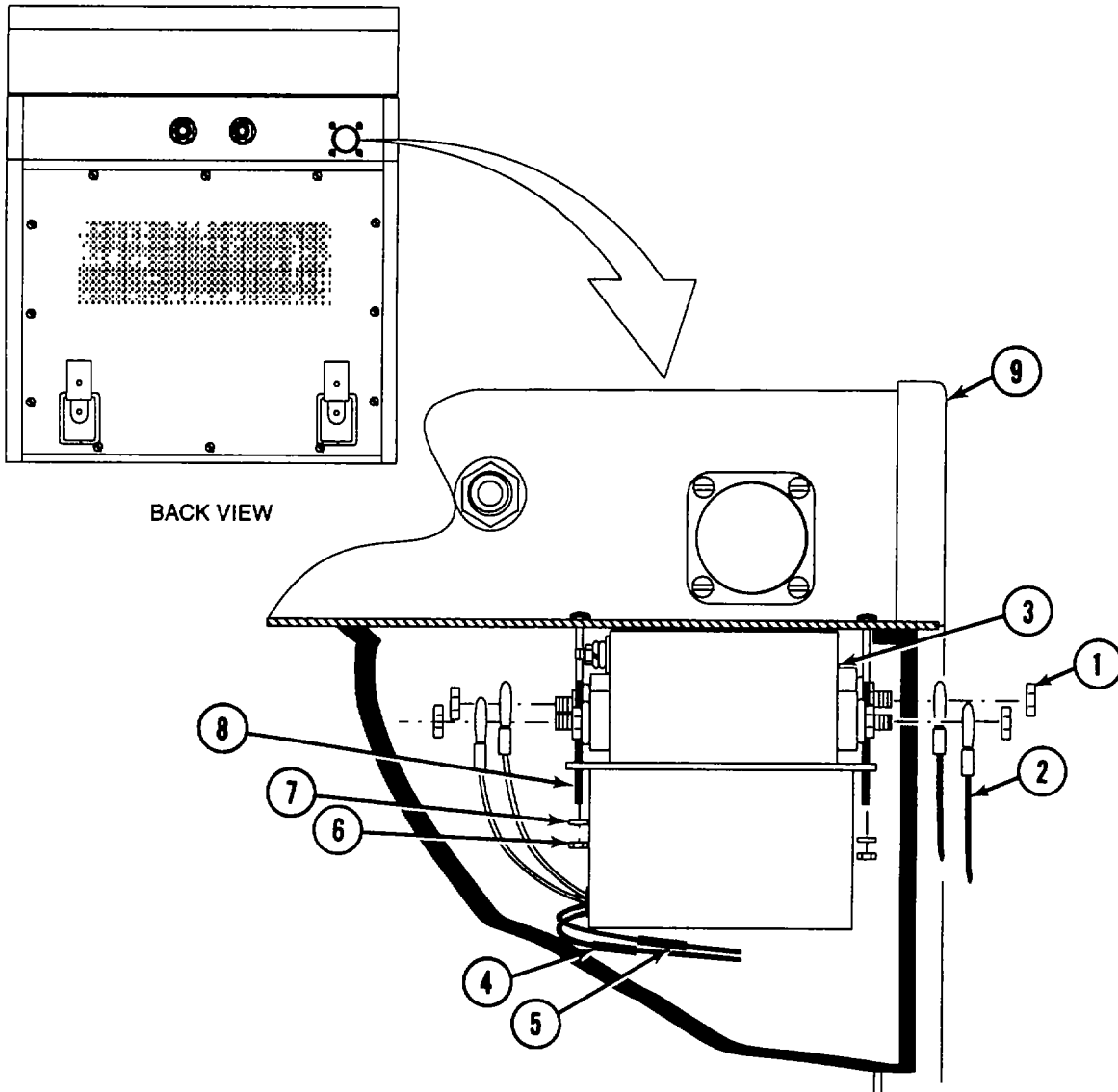

BACK VIEW

GO TO NEXT PAGE

4-37. REMOVE AND REPLACE EMI FILTER (Cont)
(Sheet 2 of 2)**4-37.1. REMOVAL**

- a. Remove four nuts (1) securing wires (2) to EMI filter (3).
- b. Tag & remove wires (2).
- c. Remove sleeving on wires (4 and 5).
- d. Tag and unsolder wires (4 and 5).
- e. Remove two mounting nuts (6) and two washers (7) from two mounting screws (8).
- f. Remove EMI filter (3) from chassis (9).

4-37.2. INSTALLATION

- a. Install EMI filter (3) on mounting screws (8) in chassis (9).
- b. Secure EMI filter (3) to chassis (9) by installing two washers (7) and two mounting nuts (6) to two mounting screws (8).
- c. Position wires (2) on EMI filter (3) and secure with four nuts (1).
- d. Install sleeving (D2) to two wires (4 and 5).
- e. Using solder (D5), remove tags and solder two wires (4 and 5).
- f. Slide sleeving over solder joints and shrink in place.

4-37.3. FOLLOW ON MAINTENANCE

Performance check (para. 2-5)

END OF TASK

4-38. REMOVE AND REPLACE POWER CONNECTOR
(Sheet 1 of 2)

Personnel Required:

Tools/Test and Support Equipment:

Materials/Parts:

Equipment Conditions:

35H TMDE Support Specialist

Tool kit (B2) or Shop Set (B4)

Connector, Heat Shrink (D2), Solder (D5)

Power disconnected, left side panel and rear panel removed (para. 4-15)

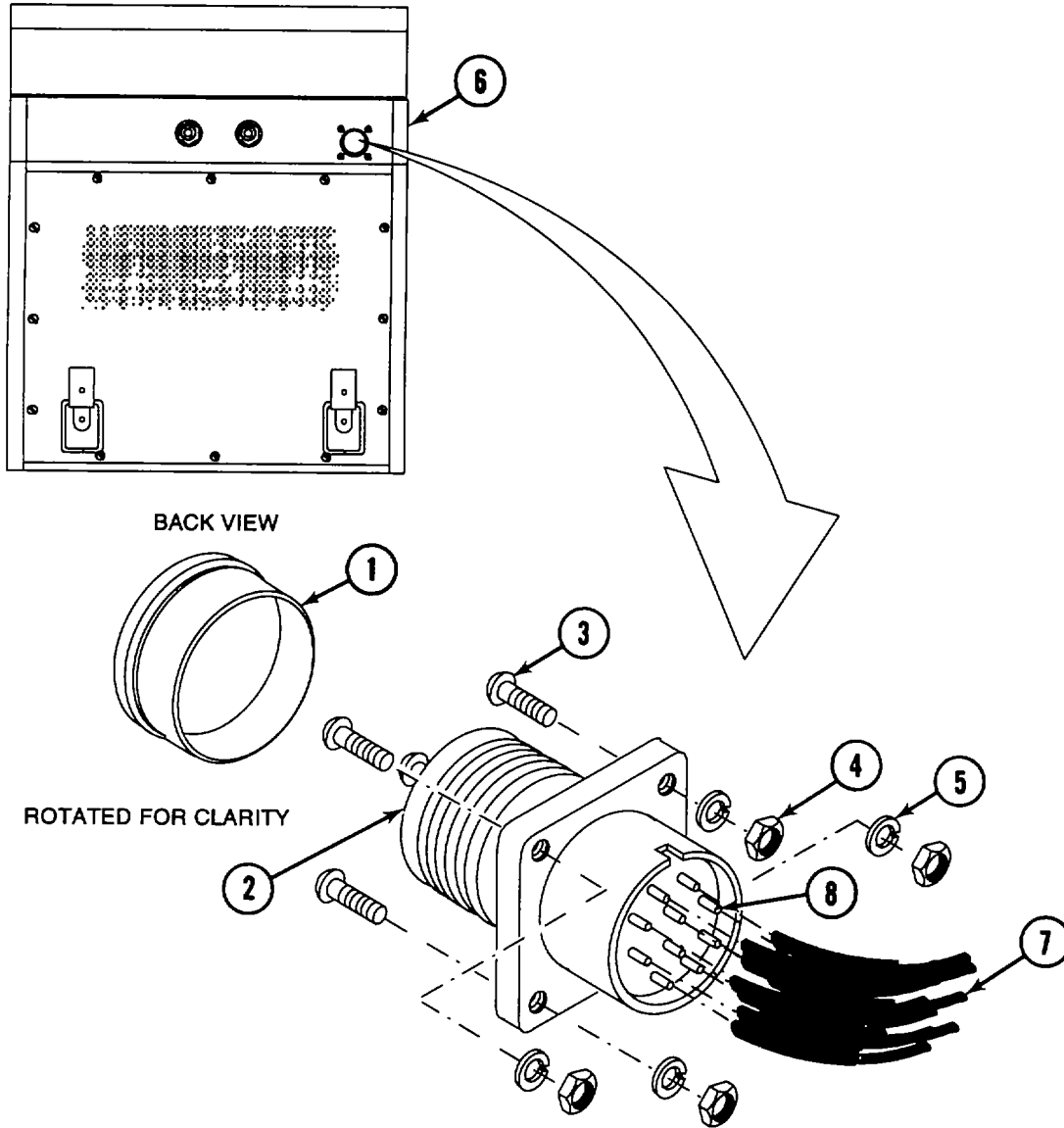

GO TO NEXT PAGE

**4-38. REMOVE AND REPLACE POWER CONNECTOR (Cont)
(Sheet 2 of 2)****4-38.1. REMOVAL**

- a. Remove connector cap (1) from power connector (2).
- b. Remove four mounting screws (3) four nuts (4) and four lock washers (5) from power connector (2).
- c. Remove power connector (2) from chassis (6) to access wires (7).
- d. Tag wires (7) and remove heat shrink (D2).
- e. Unsolder wires (7) from connector solder cups (8) and remove power connector (2).

4-38.2. INSTALLATION

- a. Slide heat shrink (D2) onto wires (7).
- b. Using solder (D5), solder wires (7) to connector solder cups (8) and place heat shrink (D2) over connector solder cups (8).
- c. Install heat shrink (D2).
- d. Install power connector (2) in chassis (6) with key way pointing up, and secure with four mounting screws (3), four lockwashers (5) and four nuts (4).
- e. Install cap (1) on power connector (2).

4-38.3. FOLLOW ON MAINTENANCE

Performance check (para. 2-5)

END OF TASK

4-39. REMOVE AND REPLACE DIODE PLATE
 (Sheet 1 of 2)

Personnel Required:

Tools/Test and Support Equipment:

Materials/Parts:

Equipment Conditions:

35H TMDE Support Specialist

Tool kit (B2) or Shop Set (B4)

Diode plate, solder (D5)

Power disconnected, left side and rear panels removed, (para. 4-15)

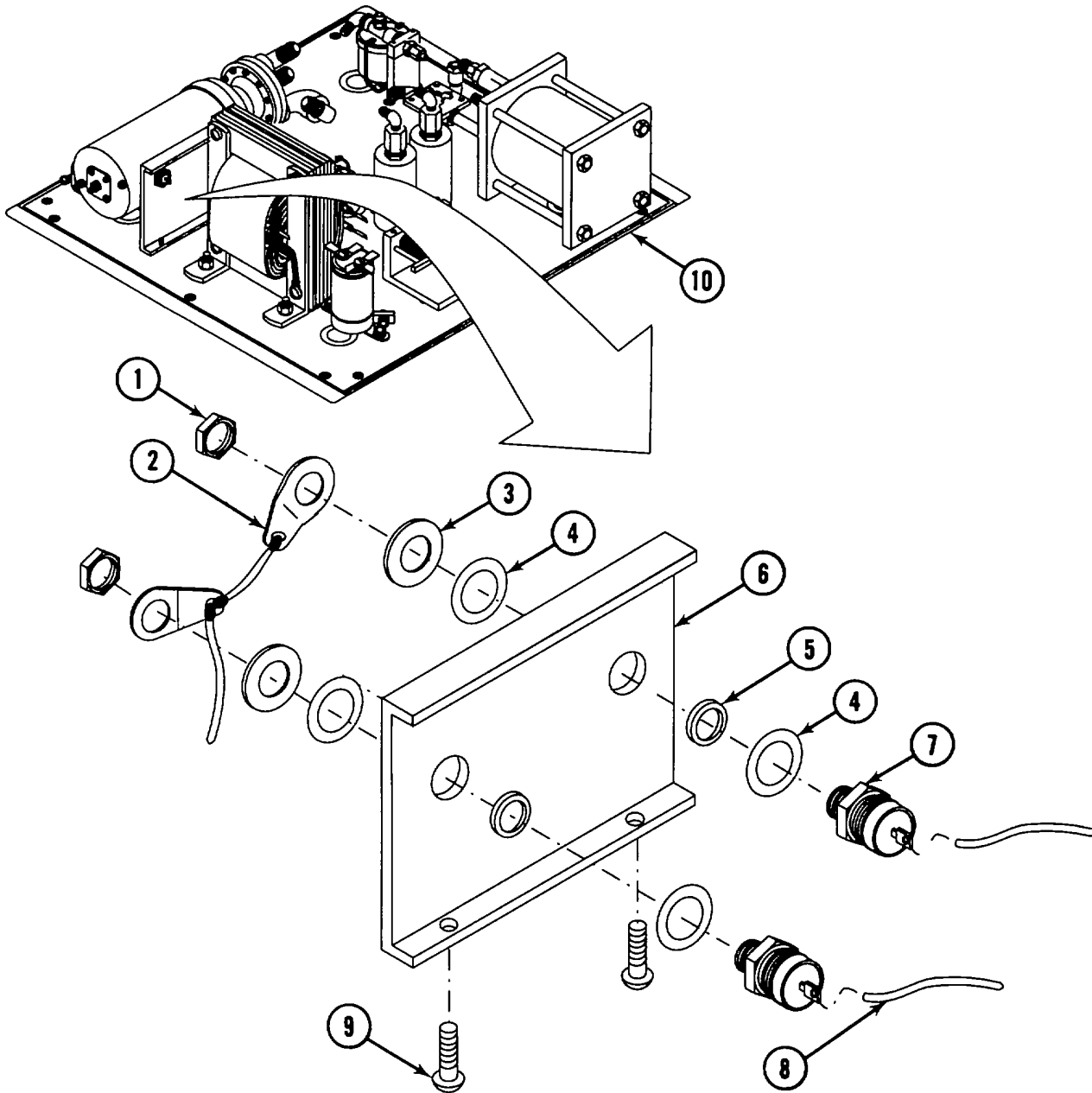

GO TO NEXT PAGE

4-39. REMOVE AND REPLACE DIODE PLATE (Cont) (Sheet 2 of 2)

4-39.1. REMOVAL

CAUTION

Holes in diode plate have plastic washers for insulation to prevent short.

- a. Remove two nuts (1), two connectors (2), two washers (3) four insulators (4) and two washers (5) from diode plate (6) and two diodes (7).
- b. Desolder and remove two wires (8) from anode end of diode eyelet.
- c. Remove two screws (9) from bottom of chassis (10).
- d. Remove diode plate (6) from chassis (10).

4-39.2. INSTALLATION

- a. Mount diode plate (6) to chassis (10) using two screws (9) through bottom of chassis (10).
- b. Using solder (D5) solder wires (8) to anode end of diode eyelet.
- c. Install two diodes (7) through diode plate (6) using two washers (5), four insulators (4), two washers (3), two connectors (2), and two nuts (1).

4-39.3. FOLLOW ON MAINTENANCE

Performance check (para. 2-5)

END OF TASK

4-40. REPAIR WIRING HARNESS
(Sheet 1 of 2)

Personnel Required:

Tools/Test and Support Equipment:

Materials/Parts:

Equipment Conditions:

35H TMDE Support Specialist

Tool kit (B2) or Shop Set (B4)

Heat Shrink (D2), Solder (D5), Cable
Ties (D1)

Power disconnected, control panel open,
all panels removed (para. 4-15)

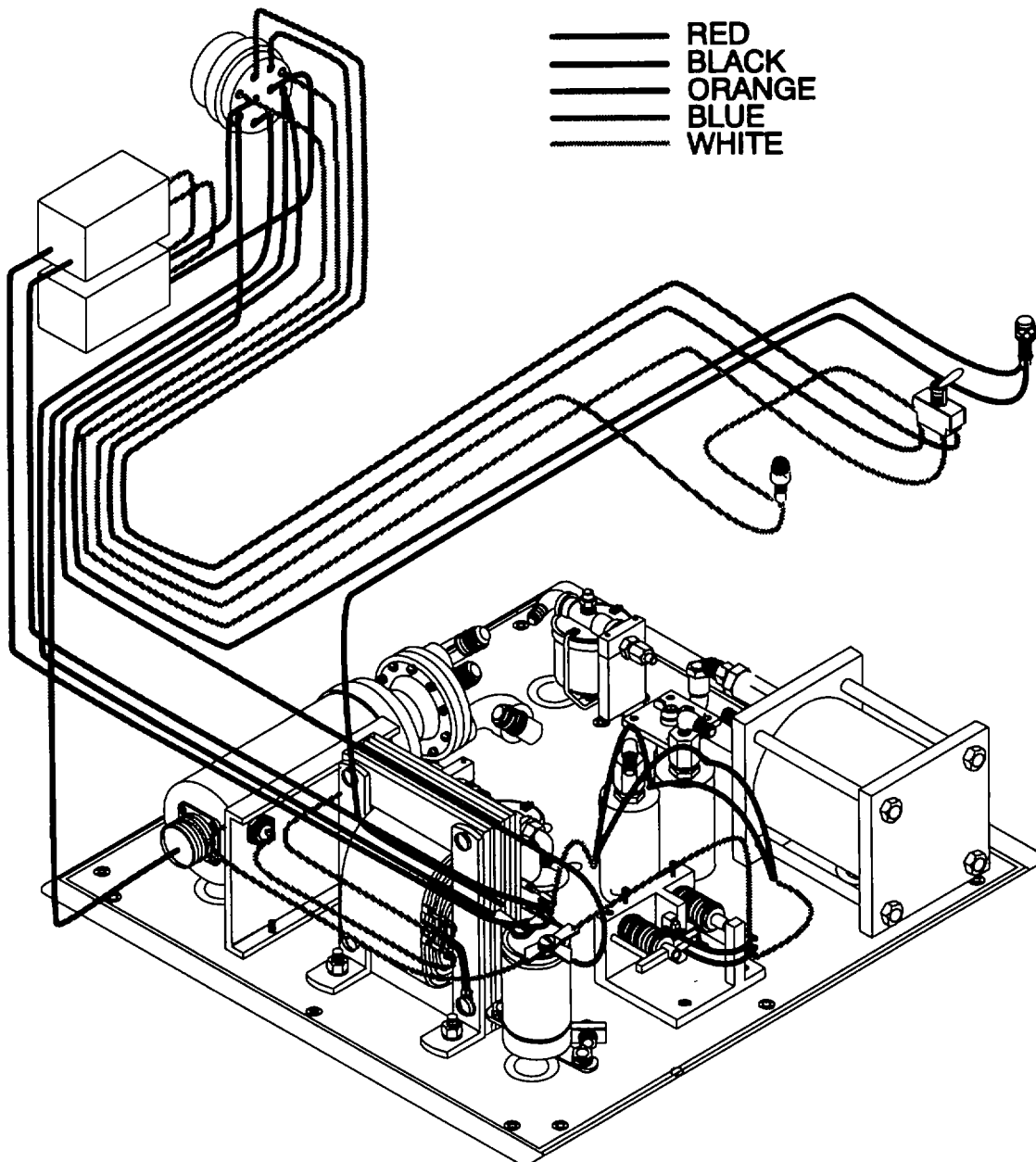

— RED
— BLACK
— ORANGE
— BLUE
— WHITE

GO TO NEXT PAGE

4-40. REPAIR WIRING HARNESS (Cont)
(Sheet 2 of 2)

4-40.1. REMOVAL

- a. Tag and unsolder and pull wires from solder connections.
- b. Tag and disconnect mechanically fastened wire leads by removing associated hardware (nuts, washers, screws etc.) or by pulling outward.

4-40.2. INSTALLATION

- a. Install wires (See G-1 & G-2).
- b. Solder wire to component leads, using solder (D5) and cover solder connections with heat shrink tubing (D2).
- c. Connect mechanically fastened wire leads and secure by installing associated hardware (nuts, washers, screws, etc.) or by pushing inward.

4-40.3. FOLLOW ON MAINTENANCE

Performance check (para. 2-5)

END OF TASK

4-41. REMOVE AND REPLACE OIL RESERVOIR AND/OR FILL & RUN SELECTOR VALVE
(Sheet 1 of 2)

Personnel Required:

Tools/Test and Support Equipment:

Materials/Parts:

Equipment Conditions:

35H TMDE Support Specialist

Tool kit (B2) or Shop Set (B4)

Oil Reservoir, Sealube (D6)

Power disconnected, valve cover panel open, control panel open, right side and front panels removed (para. 4-15)

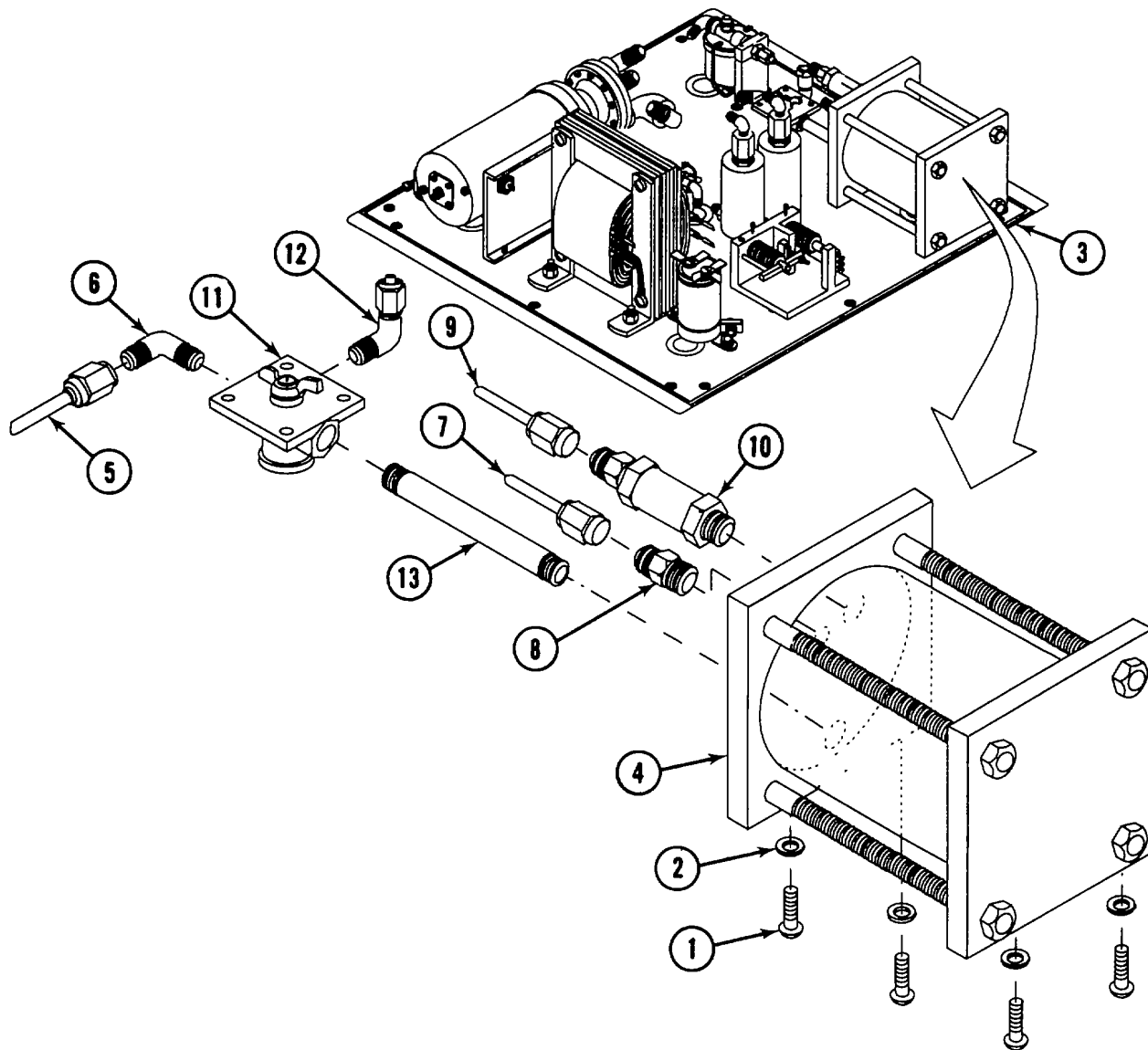

GO TO NEXT PAGE

**4-41. REMOVE AND REPLACE OIL RESERVOIR AND/OR FILL & RUN SELECTOR VALVE (Cont)
(Sheet 2 of 2)**

4-41.1. REMOVAL

NOTE

Do not tip tester with oil in the reservoir to avoid flooding check valve.

- a. Remove four screws (1) and four lockwashers (2) from bottom of chassis (3) securing oil reservoir (4).
- b. Disconnect rigid pressure line (5) from fitting (6) and disconnect rigid pressure line (7) from fitting (8).
- c. Disconnect rigid pressure line (9) from check valve assembly (10) and remove oil reservoir (4).
- d. Remove check valve assembly (10) and pour oil from reservoir (4).
- e. Remove fill and run selector valve assembly (11) and remove fittings (6, 8, 12 and 13).

4-41.2. INSTALLATION

- a. Apply Sealube (D6) to threads of all fittings.
- b. Install fittings (6, 8, 12 and 13).
- c. Install fill and run selector valve assembly (11) to reservoir (4).

NOTE

Ensure check valve arrow is pointed to rear of test set when installed.

- d. Install check valve assembly (10) to reservoir (4).
- e. Position reservoir (4) on chassis (3) and secure from bottom of chassis (3) with four screws (1) and four lockwashers (2).
- f. Connect rigid pressure line (9) to check valve assembly (10).
9. Connect rigid pressure line (7) to fitting (8) and connect rigid pressure line (5) to fitting (6).

4-41.3. FOLLOW ON MAINTENANCE

Service reservoir (Chapter 3)

Performance check (para. 2-5)

END OF TASK

4-42. REMOVE AND REPLACE RIGID PRESSURE LINES (TYPICAL)
(Sheet 1 of 2)

Personnel Required:

Tools/Test and Support Equipment:

Materials/Parts:

Equipment Conditions:

35H TMDE Support Specialist

Tool kit (B2) or Shop Set (B4)

Rigid Pressure lines

Power disconnected, valve cover panel open, control panel open, all panels removed (para. 4-15)

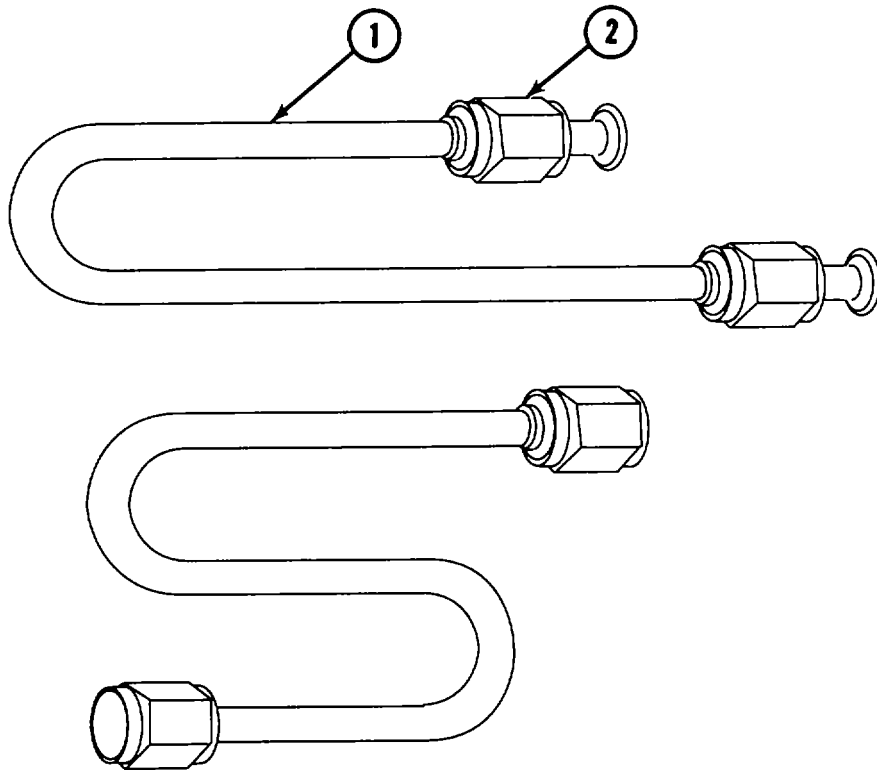

GO TO NEXT PAGE

4-42. REMOVE AND REPLACE RIGID PRESSURE LINES (TYPICAL) (Cont)
(Sheet 2 of 2)

4-42.1. REMOVAL

Disconnect pressure line (1) by turning end fitting (2) counterclockwise until disconnected. Repeat the same process for opposite end.

4-42.2. INSTALLATION

Install pressure line (1) by turning end fitting (2) clockwise. Repeat same process for opposite end.

4-42.3. FOLLOW ON MAINTENANCE

Performance check (para. 2-5)

END OF TASK

4-43. REMOVE AND REPLACE CHECK VALVES
(Sheet 1 of 2)

Personnel Required:

Tools/Test and Support Equipment:

Materials/Parts:

Equipment Conditions:

35H TMDE Support Specialist

Tool kit (B2) or Shop Set (B4)

Check Valve, Sealube (D6)

Power disconnected, side and rear panels removed (para. 4-15)

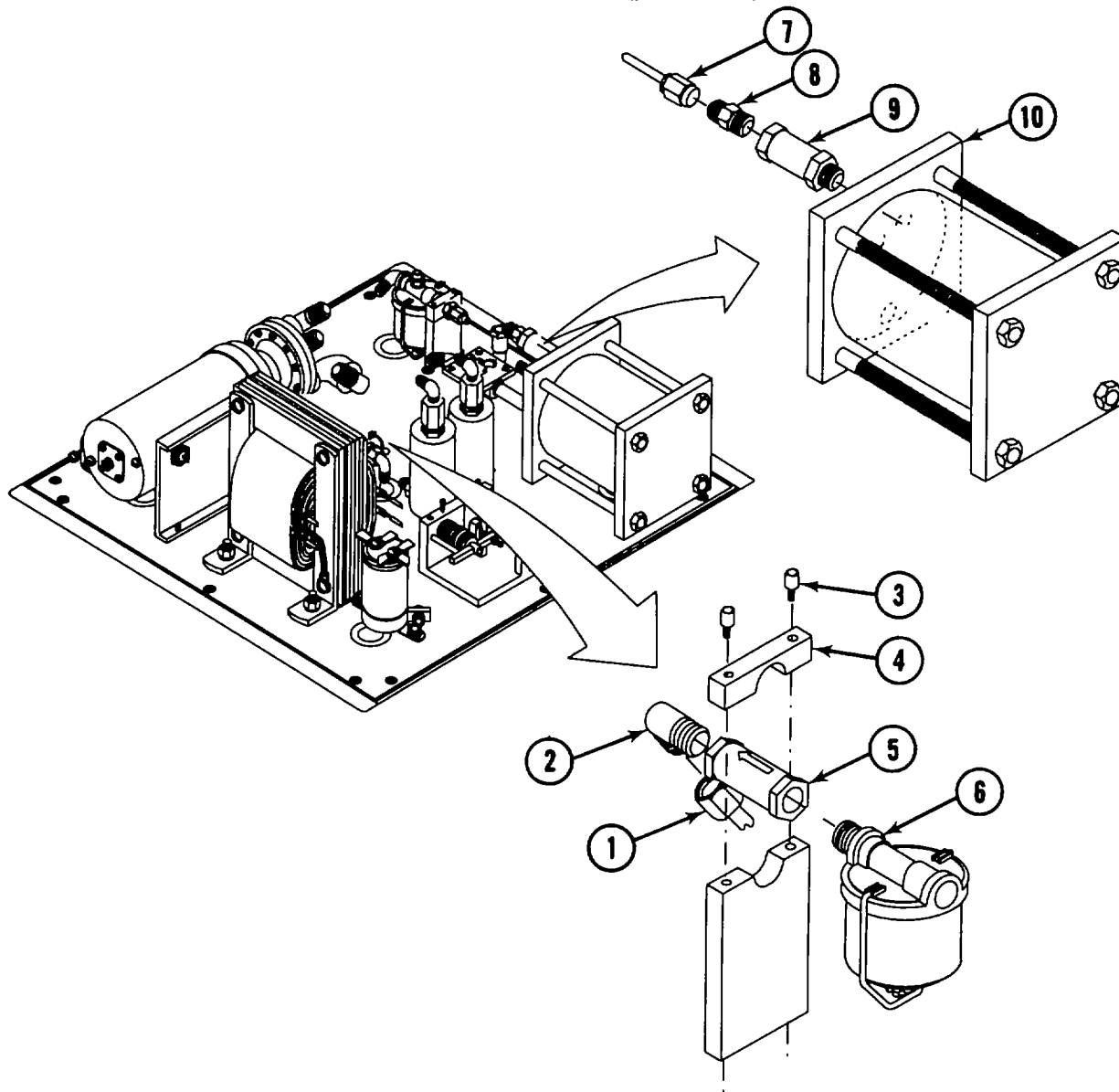

GO TO NEXT PAGE

**4-43. REMOVE AND REPLACE CHECK VALVES (Cont)
(Sheet 2 of 2)**

4-43.1. REMOVAL

- a. Remove rigid pressure line (1) from elbow fitting (2).
- b. Remove two screws (3) and bracket (4).
- c. Remove check valve (5), with elbow fitting (2) attached, from oil sump (6).
- d. Remove elbow fitting (2) from check valve (5).
- e. Remove rigid pressure line (7) from fitting (8).
- f. Remove check valve (9) from oil reservoir (10).
- g. Remove fitting (8) from check valve (9).

4-43.2. INSTALLATION

- a. Apply Sealube (D6) to threads of fittings (2 and 8) and threads of check valves (5 and 9).
- b. Install fitting (8) on check valve (9).

NOTE

Ensure check valve arrow is pointed to rear of test set when installed.

- c. Install check valve (9), with fitting (8) attached, to oil reservoir (10).
- d. Install rigid pressure line (7) to fitting (8).
- e. Install elbow fitting (2) to check valve (5).
- f. Install check valve (5), with elbow fitting (2) attached, to oil sump (6).
- g. Install two screws (3) and bracket (4).
- h. Install rigid pressure line (1) to elbow fitting (2).

4-43.3. FOLLOW ON MAINTENANCE

Performance check (para. 2-5)

END OF TASK

4-44. REMOVAL AND REPLACEMENT OF SOLENOID VALVES
 (Sheet 1 of 2)

Personnel Required:

35H TMDE Support Specialist

Tools/Test and Support Equipment:

Tool kit (B2) or Shop Set (B4)

Materials/Parts:

Solenoids, Solder (D5), Sealube (D6)

Heat Shrink (D2)

Equipment Conditions:

Power disconnected, valve cover panel open, right side front and rear panels removed, control panel open (para. 4-15)

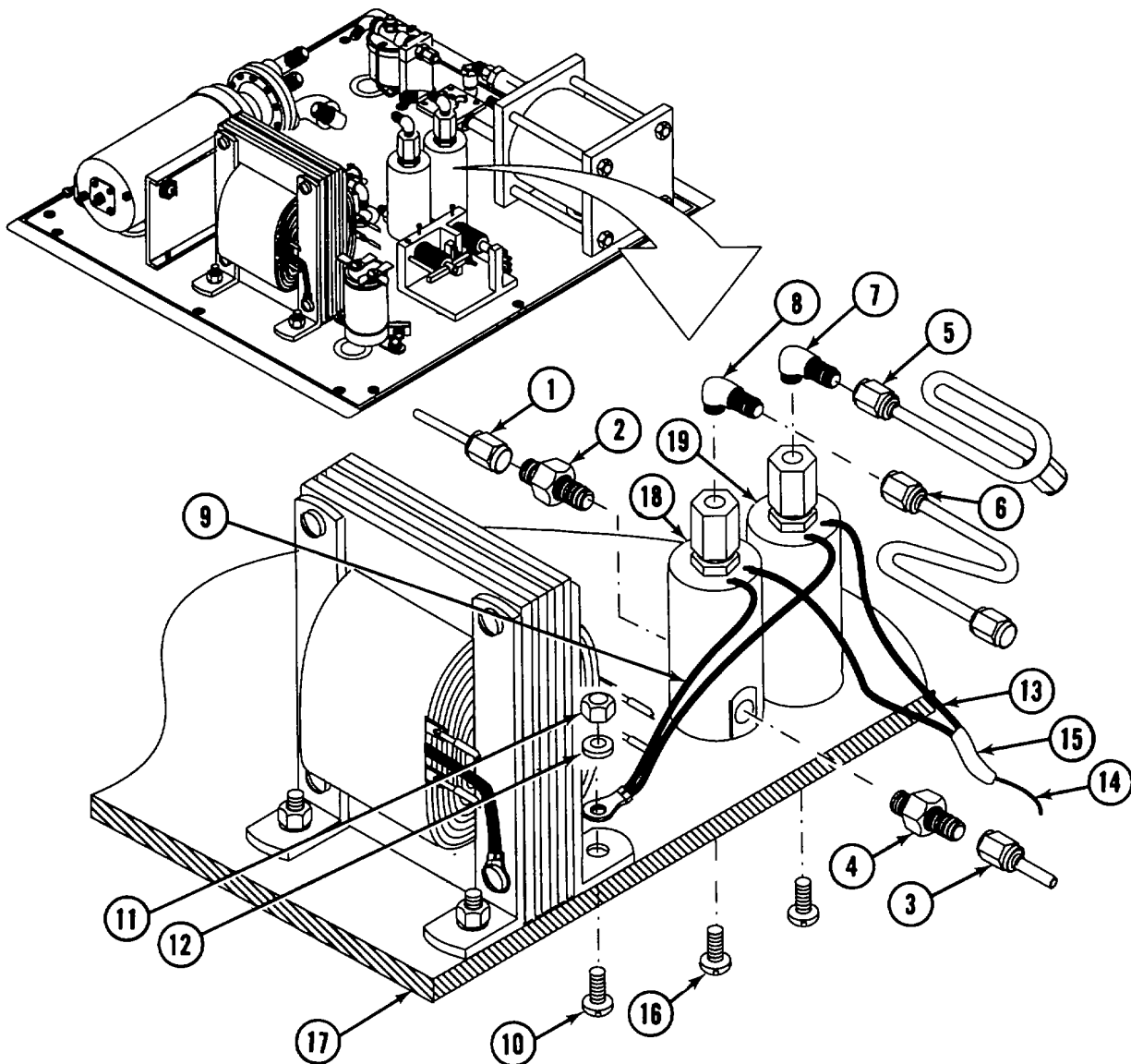

GO TO NEXT PAGE

**4-44. REMOVAL AND REPLACEMENT OF SOLENOID VALVES (Cont)
(Sheet 2 of 2)****4-44.1. REMOVAL**

- a. Disconnect rigid tubing (1) from fitting (2).
- b. Disconnect rigid tubing (3) from fitting (4).
- c. Disconnect rigid tubing (5 and 6) from elbow fittings (7 and 8).
- d. Disconnect wires (9) from mounting stud (10) by removing nut (11) and washer (12).
- e. Disconnect wires (13) from wire (14) at splice (15).
- f. Remove four screws (16) from bottom of chassis plate (17) and remove solenoid valves (18 and 19).
- g. Remove fittings (2, 4, 7 and 8) from solenoid valves (18 and 19).

4-44.2. INSTALLATION

- a. Apply sealube (D6) to threads on fittings (2, 4, 7 and 8).
- b. Attach fittings (2, 4, 7 and 8) to solenoid valves (18 and 19).
- c. Secure solenoid valves (18 and 19) to chassis bottom plate (17), using four screws (16).
- d. Splice wires (13) to wire (14) using solder (D5), and cover with heat shrink (D2).
- e. Connect wires (9) to mounting stud (10) and secure with nut (11) washer (12).
- f. Connect rigid tubing (5 and 6) to elbow fittings (7 and 8).
- g. Connect rigid tubing (1 and 3) to fittings (2 and 4).

END OF TASK

4-45. REMOVAL AND REPLACEMENT OF BELLOWS
(Sheet 1 of 2)

Personnel Required:

Tools/Test and Support Equipment:

Materials/Parts:

Equipment Conditions:

35H TMDE Support Specialist

Tool kit (B2) or Shop Set (B4)

Bellows, Solder (D5), Sealube (D6)

Control panel open, valve cover panel open, front panel removed (para. 4-15)

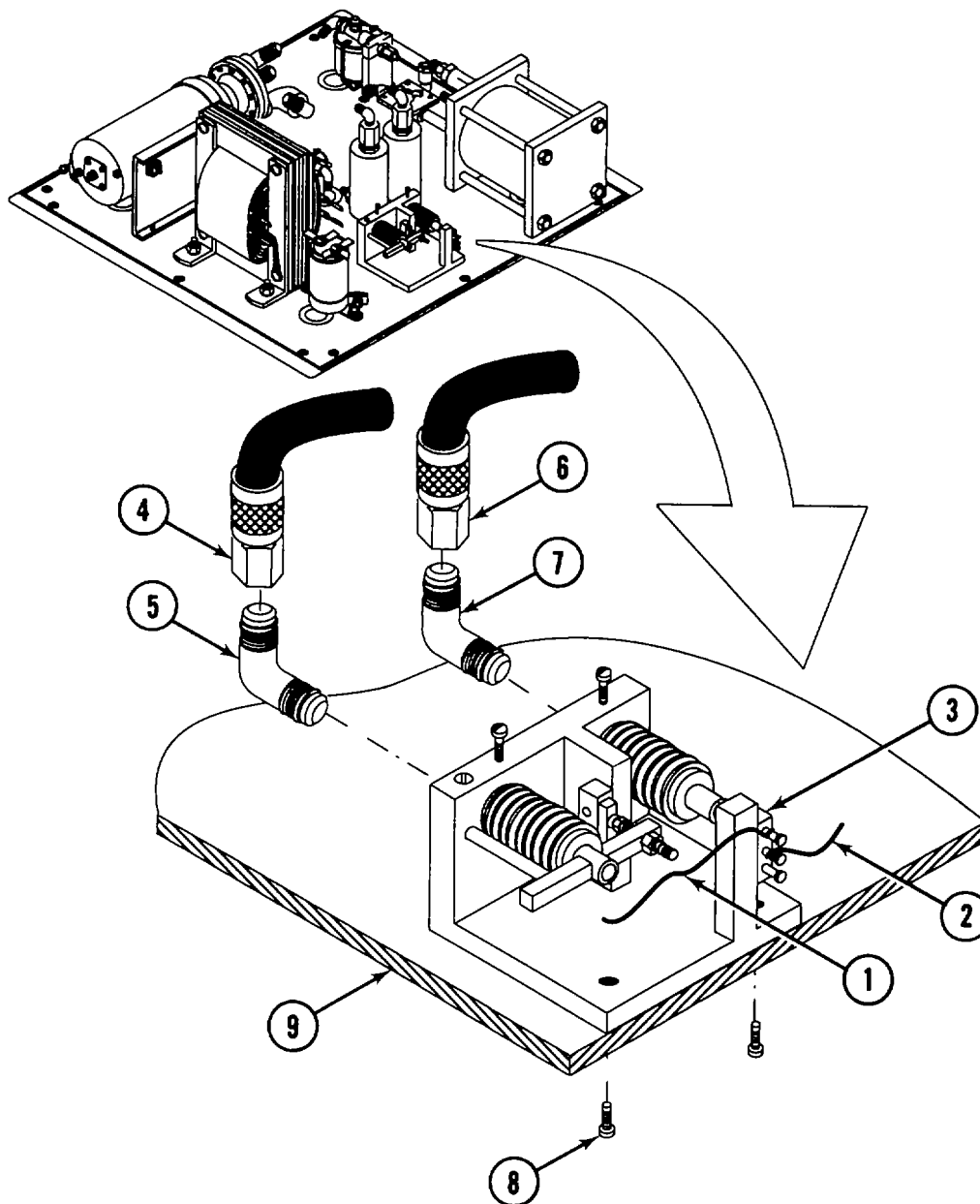

GO TO NEXT PAGE

**4-45. REMOVAL AND REPLACEMENT OF BELLOWS
(Sheet 2 of 2)**

4-45.1. REMOVAL

- a. Unsolder and remove two wires (1 and 2) from bellows (3).
- b. Tag and remove flex hose (4) from elbow fitting (5).
- c. Tag and remove flex hose (6) from elbow fitting (7).
- d. Remove two screws (8) from bottom of chassis plate (9) and remove bellows (3).
- e. Remove elbow fittings (5 and 7).

4-45.2. INSTALLATION

- a. Apply sealube (D6) to elbow fittings (5 and 7) and install.
- b. Secure bellows (3) to chassis plate (9) with two screws (8) through bottom of chassis plate (9).
- c. Attach flex hose (6) to elbow fitting (7) and remove tag.
- d. Attach flex hose (4) to elbow fitting (5) and remove tag.
- e. Using solder (D5), attach two wires (1 and 2) to bellows (3).

END OF TASK

APPENDIX A**REFERENCES****A-1. DICTIONARIES OF TERMS AND ABBREVIATIONS**

AR 310-25 Dictionary of United States Army Terms
 AR 310-50 Authorized Abbreviations and Brevity Codes

A-2. PUBLICATION INDEXES

DA PAM 25-30 Consolidated Index of Army Publications and Blank
 Forms

A-3. LOGISTICS AND STORAGE

TM 1-1500-204-23 (Series) General Aircraft Maintenance Manual

TM 743-200-1 Storage and Materials Handling

A-4. MAINTENANCE OF SUPPLIES AND EQUIPMENT

AR 750-1 Army Material Maintenance Concepts and Policies and
 Retain Maintenance Operations

DA PAM 738-751 Functional Users manual for the Army Maintenance
 Management System-Aviation (TAMMS-A)

TM 43-0139 Painting Operations Instructions for Field Use

TB 43-180 Calibration and Repair Requirements for the
 Maintenance of Army Material

A-5. OTHER PUBLICATIONS

AR 420-90 Fire Protection

AR 55-38 Reporting of Transportation Discrepancies in
 Shipments

AR 700-58 Packaging Improvement Report

DA PAM 310-13 Posting and Filing Publications

FM 21-11 First Aid for Soldiers

TM 750-244-1-4 Procedures for the Destruction of Aviation
 Ground Support Equipment (FSC 4920) to Prevent
 Enemy Use

APPENDIX B

MAINTENANCE ALLOCATION CHART

SECTION I. Introduction

B-1. GENERAL

- a. This section provides a general explanation of all maintenance and repair functions authorized at various maintenance categories.
- b. The Maintenance Allocation Chart (MAC) in Section II designates overall authority and responsibility for the performance of maintenance functions on the identified end item or component. The application of the maintenance functions to the end item or component will be consistent with the capacities and capabilities of the designated maintenance categories.
- c. Section III lists the tools and test equipment (both special tools and common tool sets) required for each maintenance function as referenced from Section II.
- d. Section IV contains supplemental instructions and explanatory notes for a particular maintenance function.

B-2. MAINTENANCE FUNCTIONS

- a. Inspect - to determine the serviceability of an item by comparing its physical, mechanical, an/or electrical characteristics with established standards through examination (e.g. - by sight, sound or feel).
- b. Replace - to remove an unserviceable item and install a serviceable counterpart in its place "Replace" is authorized by the MAC and is shown as the 3rd position code of the SMR code.
- c. Repair - the application of maintenance services, including fault location/ troubleshooting, removal/installation, and disassembly/assembly procedures, and maintenance actions to identify troubles and restore serviceability to an item by correcting specific damage, fault, malfunction, or failure in a part, subassembly, module (component or assembly), end item, or system.
- d. Calibrate - to determine and cause corrections to be made or to be adjusted on instruments or test, measuring, and diagnostic equipment used in precision measurement. Consists of comparisons of two instruments, one of which is a certified standard of known accuracy, to detect and adjust any discrepancy in the accuracy of the instrument being compared.

- e. Test - to verify serviceability by measuring the mechanical, pneumatic, hydraulic, or electrical characteristics of an item and comparing those characteristics with prescribed standards.

B-3. EXPLANATION OF COLUMNS IN THE MAC, SECTION II

- a. Column 1, Group Number - Column 1 lists functional group code numbers, the purpose of which is to identify maintenance significant components, assemblies, subassemblies, and modules with the next higher assembly. End item group number shall be "00".
- b. Column 2, Component/Assembly - Column 2 contains the names of components assemblies, subassemblies, and modules for which maintenance is authorized.
- c. Column 3, Maintenance Function - Column 3 lists the functions to be performed on the item listed in Column 2. (For detailed explanation of these functions, see paragraph B-2).
- d. Column 4, Maintenance Category-
 - (1)AVUM - Aviation Unit Maintenance. AVUM activities will be staffed and equipped to perform high frequency "On-Equipment" maintenance tasks required to retain or return equipment to a serviceable condition.
 - (2)AVIM - Aviation Intermediate Maintenance. AVIM provides mobile, responsive "one-stop" maintenance support. Authorized maintenance includes replacement and repair of module/components and end items which can be accomplished efficiently with available skills, tools, and equipment. AVIM inspects, troubleshoots, tests, diagnoses, repairs, adjusts, calibrates, and aligns system modules and components.
- e. Column 5, tools and Equipment - Column 5 specifies, by code, those common tool sets (not individual tools) and special tools, TMDE, and support equipment required to perform the designated function.
- f. Column 6, Remarks - This column shall, when applicable, contain a letter code, in alphabetic order, which shall be keyed to the remarks contained in Section IV.

**SECTION II. Maintenance Allocation Chart
for
Tester, Pitot and Static Systems**

Section II. MAINTENANCE ALLOCATION CHART						
(1) GROUP NUMBER	(2) COMPONENT ASSEMBLY	(3) MAINTENANCE FUNCTION	(4) MAINTENANCE CATEGORY		(5) TOOLS AND EQUIPMENT	(6) REMARKS
			AVUM	AVIM		
00	Pitot and Static Systems Tester	Inspect	.5	-.-	1, 2, 3, 4 1, 2	A
		Replace		.5		B, C
		Repair		-.-		
		Calibrate		1.0*		
01	Tester, Pitot and Static Systems	Inspect	.5	-.-	1, 2, 3, 4 1, 2	A
		Replace	.5	-.-		B, C
		Repair		-.-		
		Calibrate		-.-		
0101	Clamp Assy, Static	Inspect	.1	-.-	4	A
		Replace		.5		
0102	Connector, Pitot Assembly	Inspect	.1		2, 4	A, B
		Replace		.3		
0103	Power Cord Assy	Inspect	.5		2, 4	A, B
		Replace		.5		
0104	Power Cord Assy	Inspect	.5		2, 4	A, B
		Replace		.5		
0105	Power Cord Assy	Inspect	.5		2, 4	A, B
		Replace		.5		
0106	Power Adapter Assy	Inspect	.5		2	A, B
		Replace		.5		
0107	Cover Assy	Inspect	.2			
		Replace		.5		

*US Army Test, Measurement and Diagnostic Equipment Support Group (USATSG)

**SECTION II. Maintenance Allocation Chart
for
Tester, Pitot and Static Systems**

Section II. MAINTENANCE ALLOCATION CHART						
(1) GROUP NUMBER	(2) COMPONENT ASSEMBLY	(3) MAINTENANCE FUNCTION	(4) MAINTENANCE CATEGORY		(5) TOOLS AND EQUIPMENT	(6) REMARKS
			AVUM	AVIM		
0108	Chassis Assy	Inspect Replace Repair Calibrate	.5		1, 2, 3, 4 1, 2, 3, 4 1, 3	A B, C
010801	Door Assy, Front Replace	Inspect	.1	.5	2	A
010802	Door Assy, Right	Inspect Replace	.1	.5	2	A
010803	Door Assy, Left	Inspect Replace	.1	.5	2	A
010804	Plate Assy, Back	Inspect Replace Repair	.1	.5 1.0	2 2	A C
010805	Pressure Selector	Inspect Replace Repair	.1	.5 .5	3, 4 3, 4	A C
010806	Vacuum Selector	Inspect Replace Repair	.1	.5 .5	3, 4 3, 4	A C
010807	Airspeed Valve	Inspect Replace Repair	.1	.5 .5	3, 4 3, 4	A C
010808	Altimeter Selector	Inspect Replace Repair	.1	.5 .5	3, 4 3, 4	A C

**SECTION II. Maintenance Allocation Chart
for
Tester, Pitot and Static Systems**

Section II. MAINTENANCE ALLOCATION CHART						
(1) GROUP NUMBER	(2) COMPONENT ASSEMBLY	(3) MAINTENANCE FUNCTION	(4) MAINTENANCE CATEGORY		(5) TOOLS AND EQUIPMENT	(6) REMARKS
			AVUM	AVIM		
010809	Rate of Climb	Inspect	.1			A
		Replace		.5	3, 4	
		Repair		.5	3, 4	C
010810	Airspeed Indicator	Inspect	.1			A
		Replace		.5	1, 3	
		Repair		2.0	1, 3	C
010811	Altimeter Indicator	Calibrate		-.*		C
		Inspect	.1			A
		Replace		.5	1, 3	
010812	Rate of Climb Indicator	Repair		2.0	1, 3	C
		Calibrate		-.*	1, 3	C
		Inspect	.1			A
010813	Harness Assembly	Replace		.5	1, 3	
		Repair		2.0	1, 3	C
		Calibrate		-.*	1, 3	C
010814	Bottom Plate Assy	Inspect	.1			A
		Replace		.5	4	
		Repair		2.0	4	C
010814 01	Reservoir Assembly	Inspect	.1			A
		Replace		.5	4	
		Repair				
010814 02	Pump And Motor Assy	Inspect	.1			A
		Replace		.5	4	
		Repair		1.5	4	C
010804 03	Diode Plate Assy	Inspect		.1		A
		Replace		.5	4	B, C
		Repair		.5	4	C

*US Army Test, Measurement and Diagnostic Equipment Support Group (USATSG)

**SECTION II. Maintenance Allocation Chart
for
Tester, Pitot and Static Systems**

Section II. MAINTENANCE ALLOCATION CHART							
(1) GROUP NUMBER	(2) COMPONENT ASSEMBLY	(3) MAINTENANCE FUNCTION	(4) MAINTENANCE CATEGORY		(5) TOOLS AND EQUIPMENT	(6) REMARKS	
			AVUM	AVIM			
010814 04	Bellows Block Assy	Inspect	.1		4	A	
		Replace		.5		B, C	
		Repair		.5		C	
010814 05	Filter Assembly	Inspect			4	A	
		Replace	.5			4	C
		Repair	.5			4	
010814 06	Solenoid Valve	Inspect		.1	3, 4	A	
		Replace		.5			
010814 07	Solenoid Valve	Inspect		.1	3, 4	A	
		Replace		.5			
010814 08	Metering Valve	Inspect		.1	1, 3	A	
		Replace		.5			
010814 09	Metering Valve	Inspect		.1	4	A	
		Replace		.5			

SECTION III. Tools and Test Equipment Requirements

REFERENCE CODE	MAINTENANCE CATEGORY	NOMENCLATURE	NATIONAL STOCK NUMBER	TOOL NUMBER
1	F	AN/GSM-286/287	6695-01-081-0960	-----
2	F	Tool Kit Electrical or equivalent	5180-00-323-4915	SC5180-99-A06
3	F	Tool Kit, Airframe Repair	5180-00-323-4876	SC5180-99-A02
4	F	Shop Set AVIM, Electric/Instrument	4920-00-165-1453	SC4920-99-A80

SECTION IV. MAC Reference Code and Remarks

MAINTENANCE ALLOCATION CHART	
REFERENCE CODE	REMARKS
A	Visual inspection only
B	Continuity test
C	Replace components

APPENDIX C

REPAIR PARTS AND SPECIAL TOOLS LIST

SECTION I. Introduction

C-1. SCOPE

This RPSTL lists and authorizes spares and repair parts; special tools; special test, measurement, and diagnostic equipment (TMDE); and other special support equipment required for performance of AVIM/AVUM maintenance of the pitot & static systems tester. It authorizes the requisitioning, issue, and disposition of spares, repair parts and special tools as indicated by the source, maintenance and recoverability (SMR) codes.

C-2. GENERAL

In addition to Section I, Introduction, this Repair Parts and special Tools List is divided into the following sections:

- a. Section II. Repair Parts List - A list of spares and repair parts authorized by the RPSTL for use in the performance of removed for replacement of the authorized parts. Parts lists are composed of functional groups in ascending alphanumeric sequence, with the parts in each group listed in ascending in item name sequence. Repair parts kits are listed separately in their own functional group within Section II. Repair parts for repairable special tools are also listed in this illustration(s)/figure(s).
- b. Section III. Special Tools List - a list of special tools, special TMDE, and other special support equipment authorized by this RPSTL (as indicated by Basis of Issue (BOI) information in DESCRIPTION AND USABLE ON CODE column) for the performance of maintenance.
- c. Section IV. National Stock Number and Part Number Index - A list, in National Item Identification Number (NIIN) sequence of all National stock numbered items appearing in the listing, followed by a list in alphanumeric sequence of all part numbers appearing in the listings. National stock numbers and part numbers are cross-referenced to each illustration figure and item number appearance.

C-3. EXPLANATION OF COLUMNS (SECTIONS II AND III).

- a. ITEM NO. (Column (1)) - Indicates the number used to identify items called out in the illustration.
- b. SMR CODE (Column (2)) - The Source, Maintenance, and Recoverability (SMR) code is a 5-position code containing supply/ requisitioning information, maintenance category authorization criteria, and disposition instruction, as shown in the following breakout:

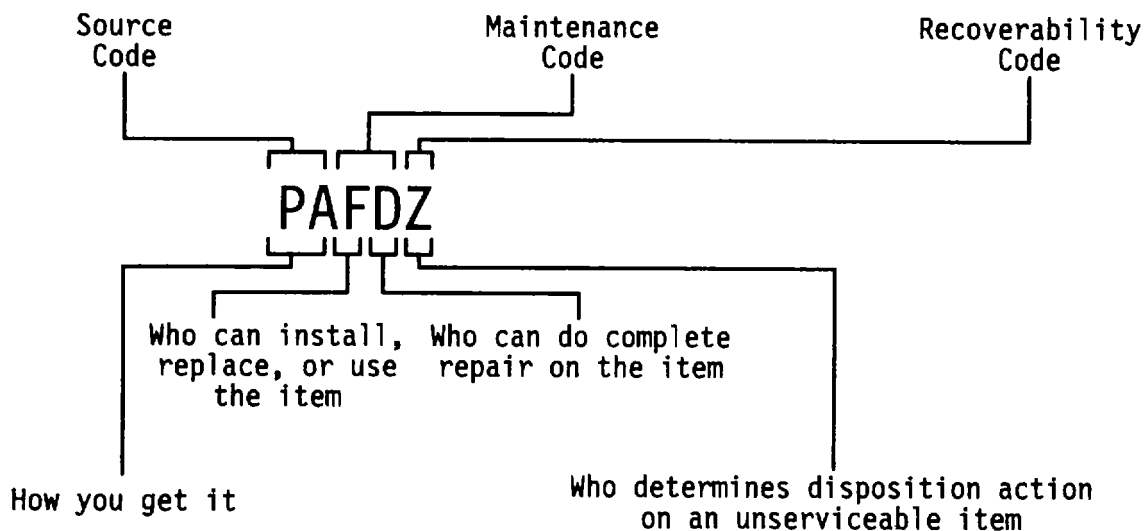

*Complete Repair: maintenance capacity, capability, and authority to perform all corrective maintenance tasks of the "Repair" function in a use/user environment in order to restore serviceability to a failed item.

(1) Source Code. The source code tells you how to get an item needed for maintenance, repair, or overhaul of an end item/equipment. Explanations of source codes follows:

Code	Explanation
PA	Stocked items; use the applicable NSN to request/requisition items with these source codes. They are authorized to the category indicated by the code entered in the 3rd position of the SMR code. **NOTE: Items coded PC are subject to deterioration
PB	
PC**	
PD	
PE	
PF	
PG	

Code	Explanation
KD KF KB	Items with these codes are not to be requested/requisitioned individually. They are part of a kit which is authorized to the maintenance category indicated in the 3rd position of the SMR code. The complete kit must be requisitioned and applied.
KO (made at Org/AVUM level) MF (made at DS/AVIM level) MH (made at GS level) ML (made at Specialized Repair Activity (SRA) MD (made at Depot)	Items with these codes are not to be requested/requisitioned individually. They must be made from bulk material which is identified by part number in the DESCRIPTION AND USABLE ON CODE (UOC) column and listed in the Bulk Material group of the repair parts list in this RPSTL. If the item is authorized to you by the 3rd position of the SMR code, but the source code indicates it is made at a higher level, order the item from the higher level of maintenance.
AO (assembled at Org/AVUM level) AF (assembled at DS/AVIM level) AH (assembled at GS level) AL (assembled by SRA) AD (assembled at Depot)	Items with those codes are not to be requested/requisitioned individually. The parts that make up the assembled item must be requisitioned or fabricated at the level of maintenance indicated by the source code. If the 3rd position authorizes you to replace the item, but the source code indicates the item is assembled at a higher level, order the item from the higher level of maintenance.
XA	Do not requisition an "XA"-coded item. Order its next higher assembly. (Also, refer to the NOTE below.
XB	If an "XB" item is not available for salvage, order it using the CAGE and part number given.
XC	Installation drawing, diagram, instruction sheet, field service drawing, that is identified by manufacturer's part number.

NOTE: Cannibalization or controlled exchange, when authorized, may be used as a source of supply for items with the above source codes, except for those source coded "XA" or those aircraft support items restricted by requirements of AR 700-42.

(2) Maintenance Code - maintenance code tells you the level(s) of maintenance authorized to USE and REPAIR support items. The maintenance codes are entered in the third and fourth positions of the SMR Code as follows:

- a. The maintenance code entered in the third position tells you the lowest maintenance level authorized to remove, replace, and use an item. The maintenance code entered in the third position will indicate authorization to one of the following levels of maintenance.

Code	Application/Explanation
C	Crew or operator maintenance done within organizational or aviation unit maintenance.
0	Organizational or aviation unit category can remove, replace, or use the item.
F	Direct support or aviation intermediate level can remove, replace, or use the item.
H	General support level can remove, replace, or use the item.
L	Specialized repair activity can remove, replace, or use the item.
D	Depot level can remove, replace, or use the item.

- b. The maintenance code entered in the fourth position tells whether or not the item is to be repaired and identifies the lowest maintenance level with the capability to do complete repair (i.e., perform all authorized repair functions.)

NOTE: Some limited repair may be done on the item at a lower level of maintenance, if authorized by the maintenance allocation Chart (MAC) and SMR codes.

This portion will contain one of the following maintenance codes.

Code	Application/Explanation
0	Organizational (or aviation unit) is the lowest level that can do complete repair on the item.
F	Direct support or aviation intermediate is the lowest level that can do complete repair on the item.
H	General support is the lowest level that can do complete repair on the item.
L	Specialized repair activity (designates the specialized repair activity) is the lowest level that can do complete repair on the item.
D	Depot is the lowest level that can do complete repair on the item.
Z	Nonrepairable. No repair is authorized.
B	No repair is authorized. (No parts or special tools are authorized for the maintenance of a "B"-coded item.) However, the item may be reconditioned by adjusting, lubricating, etc., at the user level.

(3) Recoverability Code Recoverability codes are assigned to items to indicate the disposition action on unserviceable items. The recoverability code is entered in the fifty position of the SMR Code as follows:

Code	Application/Explanation
Z	Nonrepairable Item. When unserviceable, condemn and dispose of item at the level of maintenance shown in the 3rd position of the SMR code.
0	Repairable Item. When uneconomically repairable, condemn and dispose of item at organizational or aviation unit level.
F	Repairable Item. When unserviceable, condemn and dispose of item at the direct support level.
H	Repairable Item. When uneconomically repairable, condemn and dispose of item at general support level.
D	Repairable Item. When beyond lower level repair capability, return to depot. Condemnation and disposal of item not authorized below depot level.
L	Repairable Item. Condemnation and disposal not authorized below specialized repair activity.
A	Item requires special handling or condemnation procedures because of specific reasons (e.g., precious metal content, high dollar value, critical material, or hazardous material). Refer to appropriate manuals/directives for specific instructions.

- c. CAGE (Column (3)). The Commercial and Government Entity Code (CAGE) is a 5-digit alphanumeric code which is used to identify the manufacturer, distributor, or Government agency, etc., that supplies the item.
- d. PART NUMBER (Column (4)). Indicates the primary number used by the manufacturer (individual, company, firm, corporation, or Government activity), which controls the design and characteristics of the item by means of its engineering drawings, specifications standards, and inspection requirements to identify an item or range of items.

NOTE: When you use an NSN to requisition an item, the item you receive may have a different part number from the part ordered.

- e. DESCRIPTION AND USABLE ON CODE (UOC) (Column (5)). This column includes the following information:
 - (1). The Federal item name and, when required, a minimum description to identify the item.
 - (2) The physical security classification of the item is indicated by the parenthetical entry (insert applicable physical security classification abbreviation, e., Phy Sec C1 (C) confidential, Phy Sec Ca (S) Secret, Phy Sec C1 (T Top Secret).

- (3). Items that are included in kits and sets are listed below the name of the kit or set.
 - (4). Spare/repair parts that make up an assembled item are listed immediately following the assembled item line entry.
 - (5). Part numbers for bulk materials are referenced in this column in the line item entry for the Item to be manufactured/fabricated.
 - (6). When the item is not used with all serial numbers of the same model, the effective serial numbers are shown on the last line of the description (before UOC).
 - (7). The usable on code, when applicable (see paragraph C-5, Special Information).
 - (8). In the Special Tools List section, the basis of issue (BOI) appears as the last line(s) in the entry for each special tool, special TMDE, and other special support equipment. When density of equipments supported exceeds density spread indicated in the basis of issue, the total authorization is increased proportionately.
 - (9). The statement "END OF FIGURE" appears just below the last item description in Column 5 for given figure in both Section II and Section III.
- f. QTY (Column (6)). The QTY (quantity per figure column) indicated the quantity of the item used in the breakout shown on the illustration figure, which is prepared for a functional group, subfunctional group, or an assembly. A "V" appearing in this column in lieu of a quantity indicates that the quantity is variable and the quantity may vary from application to application.

C-4. EXPLANATION OF COLUMNS (SECTION IV)**a. NATIONAL STOCK NUMBER (NSN) INDEX**

- (1). **STOCK NUMBER COLUMN** This column lists the NSN by National Item Identification Number (NIIN) sequence. The NIIN consists of the last nine digits of the NSN.

example: 5305-01-674-1467 - NIIN

When using this column to locate an item, ignore the first 4 digits of the NSN. However, the complete NSN should be used when ordering items by stock number.

- (2). **FIG.** Column this column lists the number of the figure where the item is identified/located. The figures are in numerical order in Section II and Section III.
- (3). **ITEM** Column The item number identifies the item associated with the figure listed in the adjacent FIG. column. This item is also identified by the NSN listed on the same line.

b. PART NUMBER INDEX Part numbers in this index are listed by part number in ascending alphanumeric sequence (i.e., vertical arrangement of letter and number combination which places the first letter of digit of each group in order A through Z, followed by the numbers 0 through 9 and each following letter or digit in like order).

- (1). **CAGE** Column Commercial and Government Entity Code (CAGE) is a 5-digit alphanumeric code used to identify the manufacturer, distributor, or Government agency, etc. that supplies the item.
- (2). **PART NUMBER** Column Indicates the primary number used by the manufacturer (individual, firm, corporation, or Government activity), which controls the design and characteristics of the item by means of its engineering drawings, specifications standards, and inspection requirements to identify an item or range of items.
- (3). **STOCK NUMBER** Column This column lists the NSN for the associated part number and manufacturer identified in the PART NUMBER and CAGE columns to the left.
- (4). **FIGURE.** Column This column lists the number of the figure where the item is identified/located in Section II and III.
- (5). **ITEM** Column The item number is that number assigned to the item as it appears in the figure referenced in the adjacent figure number column.

C-5. SPECIAL INFORMATION - Use the following subparagraphs as applicable:

- a. **USABLE ON CODE** The usable on code appears in the lower left corner of the Description column heading. Usable on codes are shown as "UOC:" in the Description Column (justified left) on the first line applicable item description/nomenclature. Uncoded items are applicable to all models. Identification of the usable on codes used in the RPSTL are:

Code	Used On
N/A	N/A

- b. **FABRICATION INSTRUCTIONS** Bulk materials required to manufacture items are listed in the Bulk Materials functional Group of the RPSTL. Part number of bulk materials are also referenced in the description column of the line item entry for the item to be manufactured/fabricated.
- c. **ASSEMBLY INSTRUCTION - N/A**
- d. **KITS -** Line item entries for repair parts kits appear in a group in Section II.
- e. **INDEX NUMBERS** Items which have the work BULK in the figure column will have an index number shown in the item number column. This index number is a cross-reference between the National Stock Number/Part Number Index and the bulk material list in Section II.
- f. **ASSOCIATED PUBLICATIONS - N/A**

C-6. HOW TO LOCATE REPAIR PARTS

A. When National Stock Number or Part Number is not known:

- STEP 1 Using the table of contents, determine the assembly group or subassembly group to which the item belongs. This is necessary since figures are prepared for assembly and subassembly groups, and listings are divided into the same groups.
- STEP 2 Find the figure covering the assembly group or subassembly group to which the item belongs.
- STEP 3 Identify the item on the figure and note the item number.
- STEP 4 Refer to the Repair Parts List for the figure to find the part number for the item number noted on the figure.
- STEP 5 Refer to the Part Number Index to find the NSN, if assigned.

B. When National Stock Number or Part Number is known:

STEP 1 Using the Index of National Stock Numbers and Part Numbers, find the pertinent National Stock Number or Part Number. the NSN index is in National Item Identification Number (NIIN) sequence (see C-4.1 (a)). The part numbers in the Part Number Index are listed in ascending alphanumeric sequence (see C-4.B). Both indexes cross-reference you to the illustration figure and Item Number of the item you are looking for.

STEP 2 After finding the figure and item number, verify that the item is the one you are looking for, then locate the item number in the repair parts list for the figure.

This Page Intentionally Left Blank

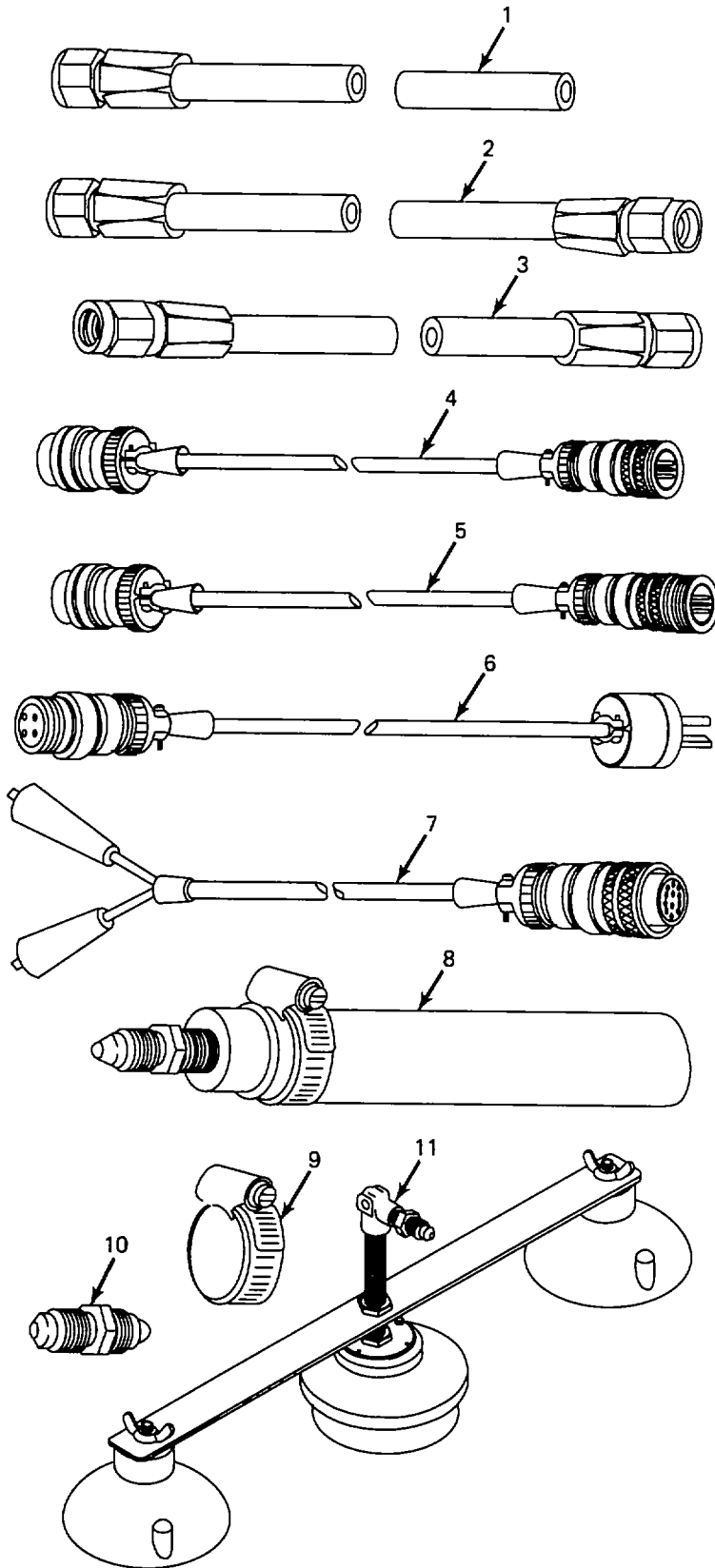

FIGURE C-1. ACCESSORIES

(1) ITEM NO	(2) SMR CODE	(3) CAGE	(4) PART NUMBER	(5) DESCRIPTION AND USABLE ON CODES(UOC) QTY	(6)
GROUP: 02 FIG. C-1 ACCESSORIES					
1	XBOZZ	59413	92-10114-6	HOSE, SUBASSEMBLY	1
2	PAOZZ	88044	AN6270-4D0060	HOSE, SUBASSEMBLY	2
3	PAOZZ	88044	AN6270-4D0072	HOSE, SUBASSEMBLY	1
4	XBOFF	59413	80-10111	POWER ADAPTER ASSY (SEE FIGURE C-14).....	1
5	XBOFF	59413	80-IOI11A	POWER CORD ASSEMBLY(SEE FIGURE C-13)	1
6	XBOFF	59413	80-10113A	POWER CORD ASSEMBLY(SEE FIGURE C-12)	1
7	XBOFF	59413	80-10112A	POWER CORD ASSEMBLY(SEE FIGURE C-11).....	1
8	XBOFF	59413	92-10118	CONNECTOR, PITOT ..(SEE FIGURE C-10)	1
9	PAOZZ	88044	AN737TW-48	CLAMP, HOSE	1
10	PAOZZ	88044	AN815-4D	UNION, FLARED TUBE	2
11	XBOFF	59413	92-10113	STATIC CLAMP ASSY (SEE FIGURE C-9).....	1

END OF FIGURE

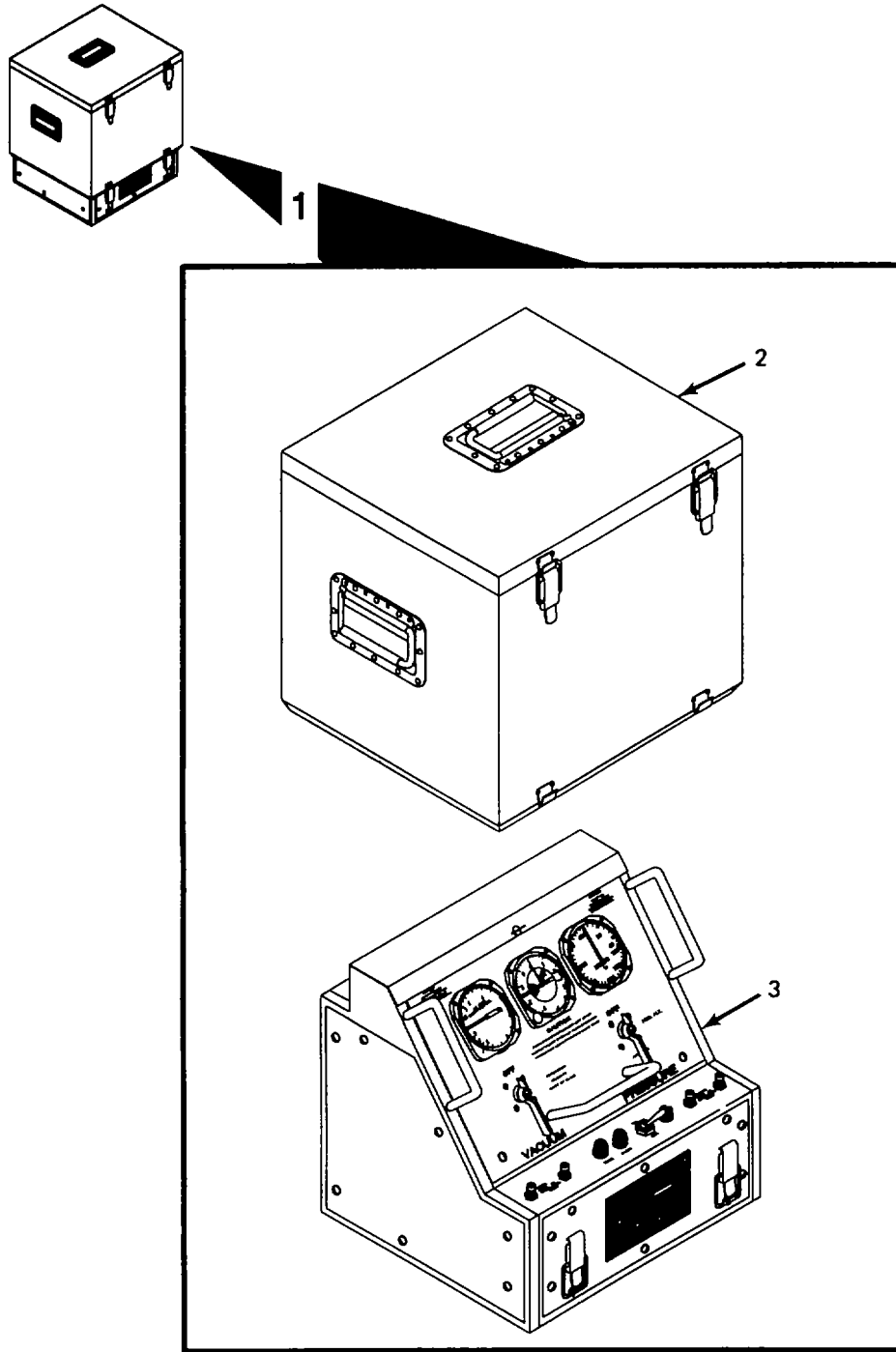

FIGURE C-2. TESTER, PITOT, AND STATIC ASSEMBLY (3400-003)

(1) ITEM NO	(2) SMR CODE	(3) CAGE	(4) PART NUMBER	(5) DESCRIPTION AND USABLE ON CODES(UOC) QTY	(6)
GROUP: 00 FIGURE C-2. PITOT, STATIC AND SYSTEMS TESTER (3400-0003)					
1	XBOFF	59413	92-10131	TESTER, PITOT AND STATIC SYSTEMS.....	1
2	XBFFF	59413	62-10058	COVER ASSEMBLY (SEE FIGURE C-3).....	1
3	XBFFF	59413	90-50025	PITOT STATIC ASSY (SEE FIGURE C-4).....	1

END OF FIGURE

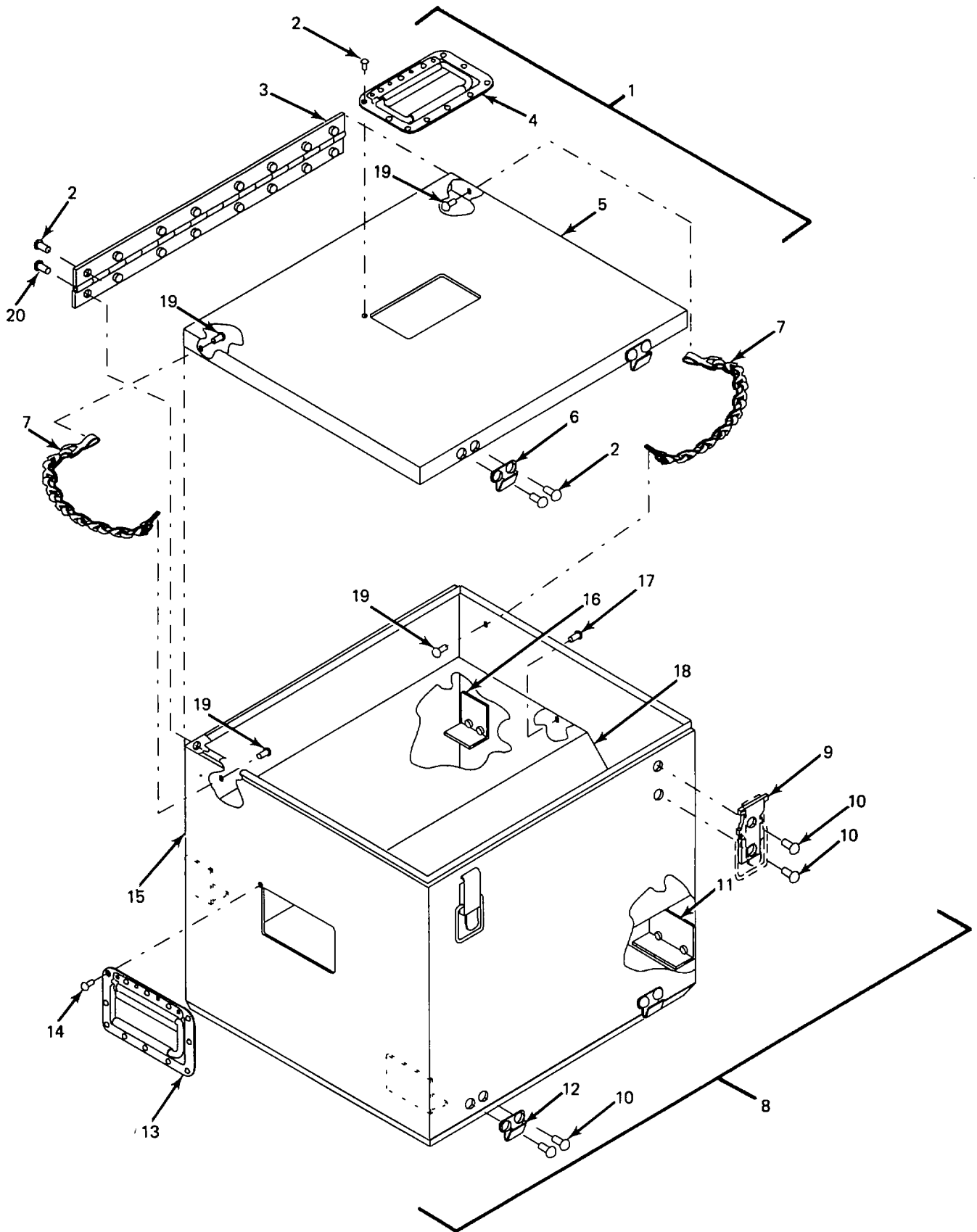

FIGURE C-3. COVER ASSEMBLY (62-1058)

(1) ITEM NO	(2) SMR CODE	(3) CAGE	(4) PART NUMBER	(5) DESCRIPTION AND USABLE ON CODES(UOC) QTY	(6)
GROUP: 0107 FIGURE C-3. COVER ASSEMBLY (62-10058)					
1	XBFFF	59413	62-10064	LID, SUBASSEMBLY	1
2	PAFZZ	96906	MS20470-A6-7	.RIVET	20
3	XBFZZ	59413	61-10015	.HINGE	1
4	XBFZZ	59413	32-10003	.HANDLE	2
5	XBFZZ	59413	35-10067	.LID, FORMED	1
6	XBFZZ	59413	51-10017	.STRIKE	2
7	XBFZZ	59413	61-10016	CHAIN, CUT	2
8	XBFFF	59413	62-10065	COVER, SUBASSEMBLY	1
9	XBFZZ	59413	51-10016	.CATCH	2
10	PAFZZ	96906	MS20470-A4-6	.RIVET	12
11	XBFZZ	59413	35-10061	.SEAT	2
12	XBFZZ	59413	51-10017	.STRIKE	4
13	XBFZZ	59413	32-10003	.HANDLE	2
14	PAFZZ	96906	MS20470-A6-7	.RIVET	24
15	XBFZZ	59413	62-10062	.COVER, TESTER	1
16	XBFZZ	59413	35-10062	.SEAT	2
17	PAFZZ	96906	MS20426A4-3	.RIVET, SOLID	44
18	XBFZZ	59413	35-10063	.PLATE SEPARATOR	1
19	PAFZZ	96906	MS20470-A4-6	RIVET	4
20	PAFZZ	96906	MS20470-A6-7	RIVET	8

END OF FIGURE

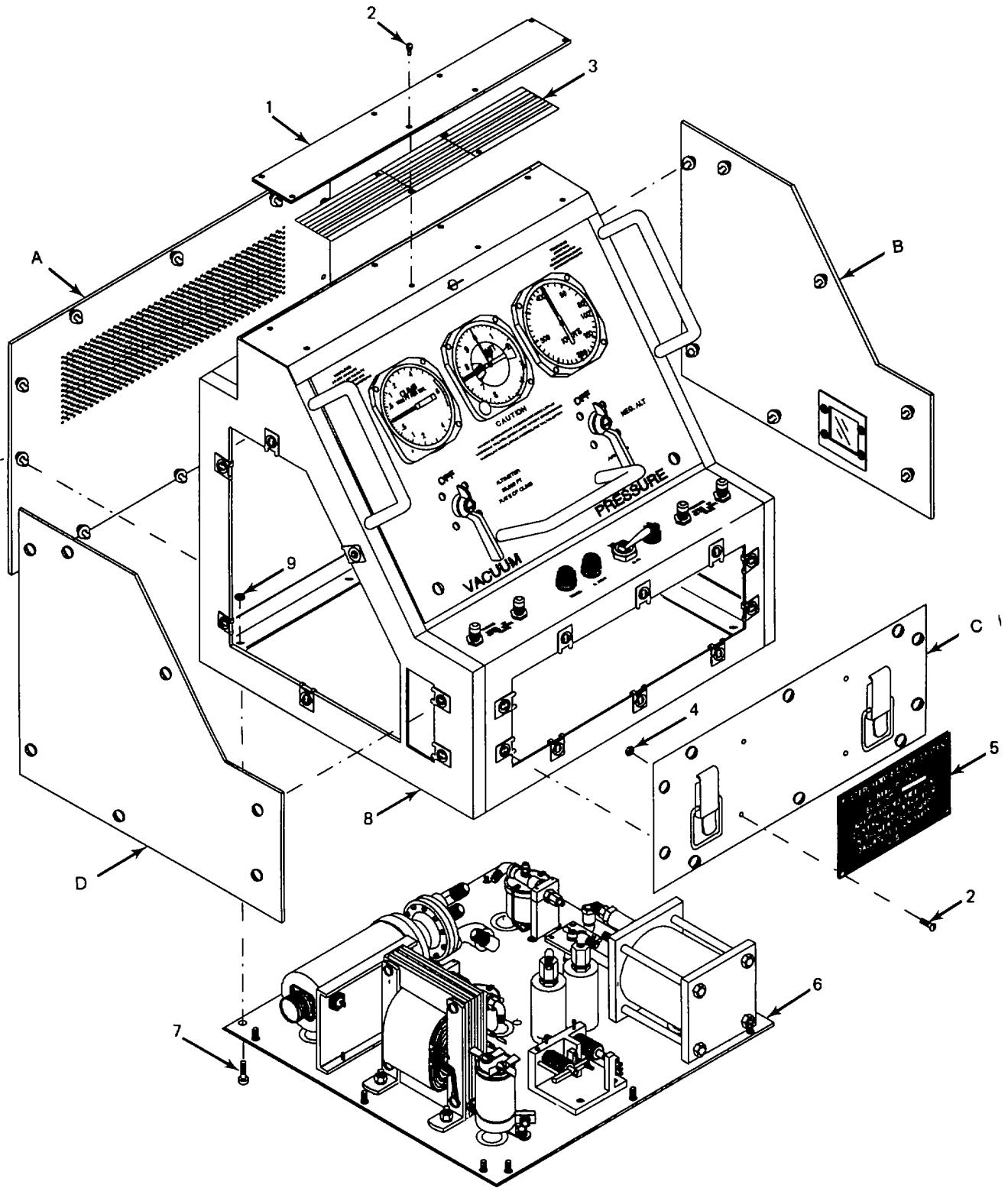

FIGURE C-4. CHASSIS ASSEMBLY (90-50025) (SHEET 1 OF 8)

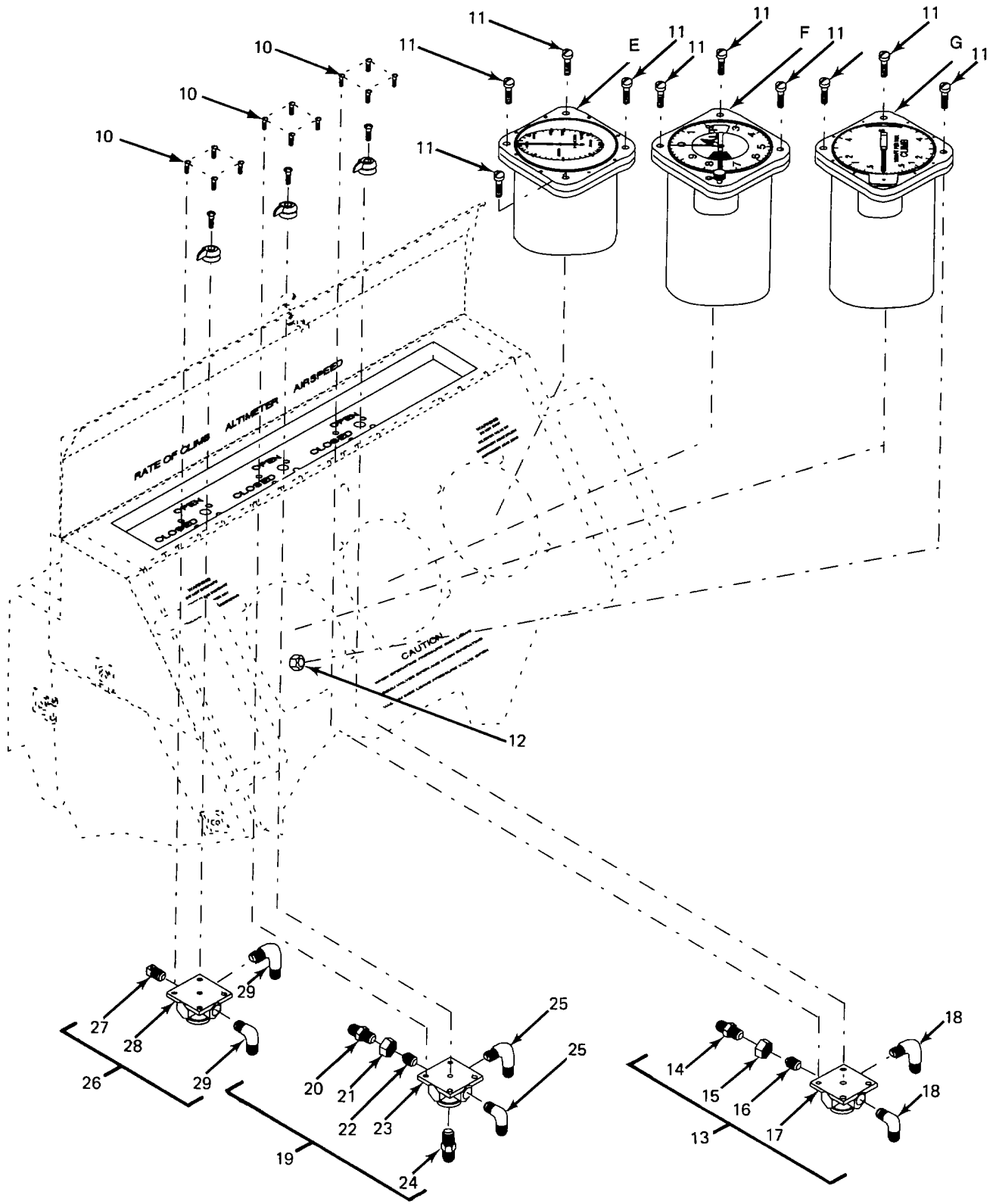
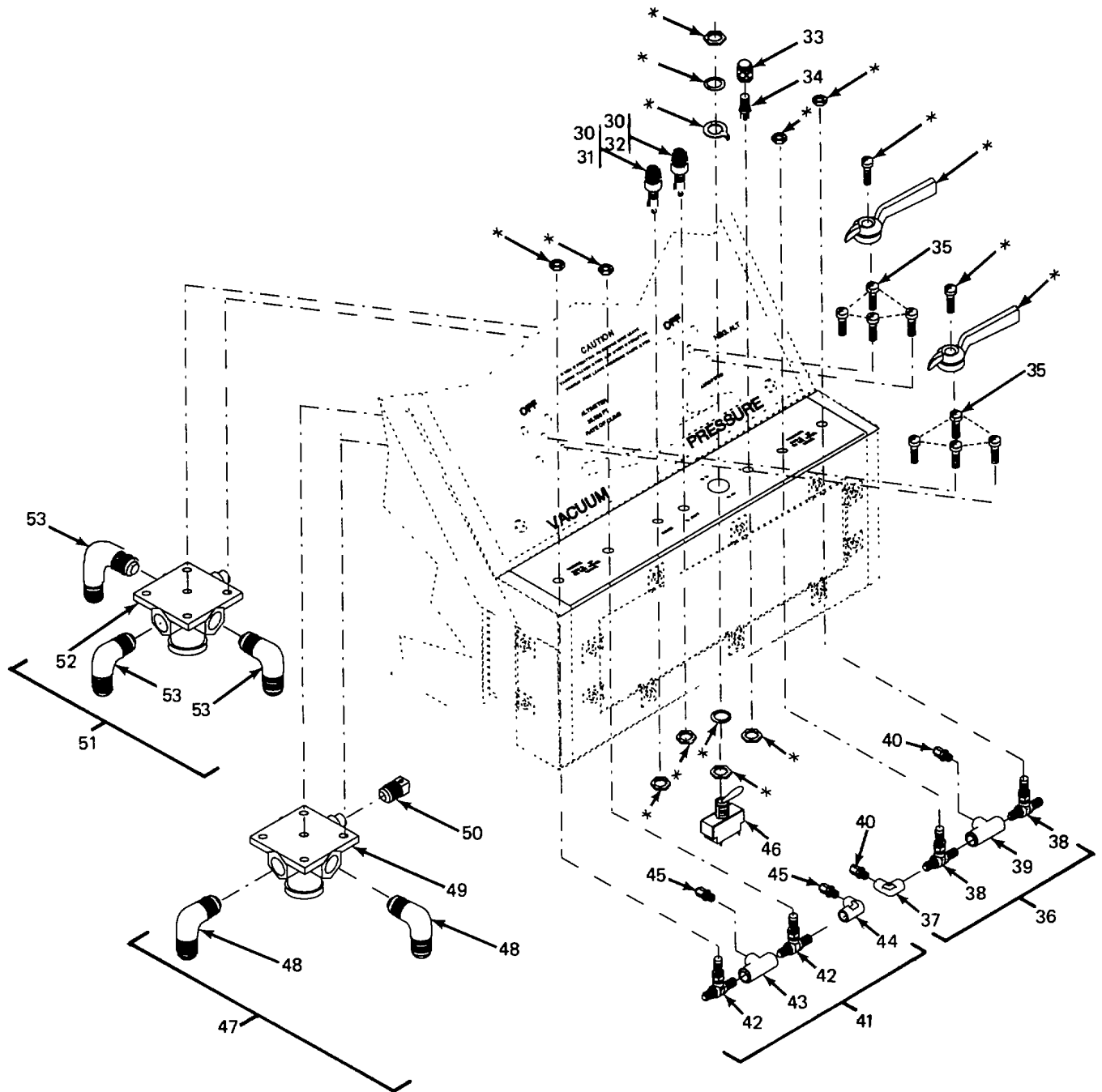

FIGURE C-4. CHASSIS ASSEMBLY (90-50025) (SHEET 2 OF 8)
C-19



*Furnished with associated item

FIGURE C-4. CHASSIS ASSEMBLY (90-50025) (SHEET 3 OF 8)

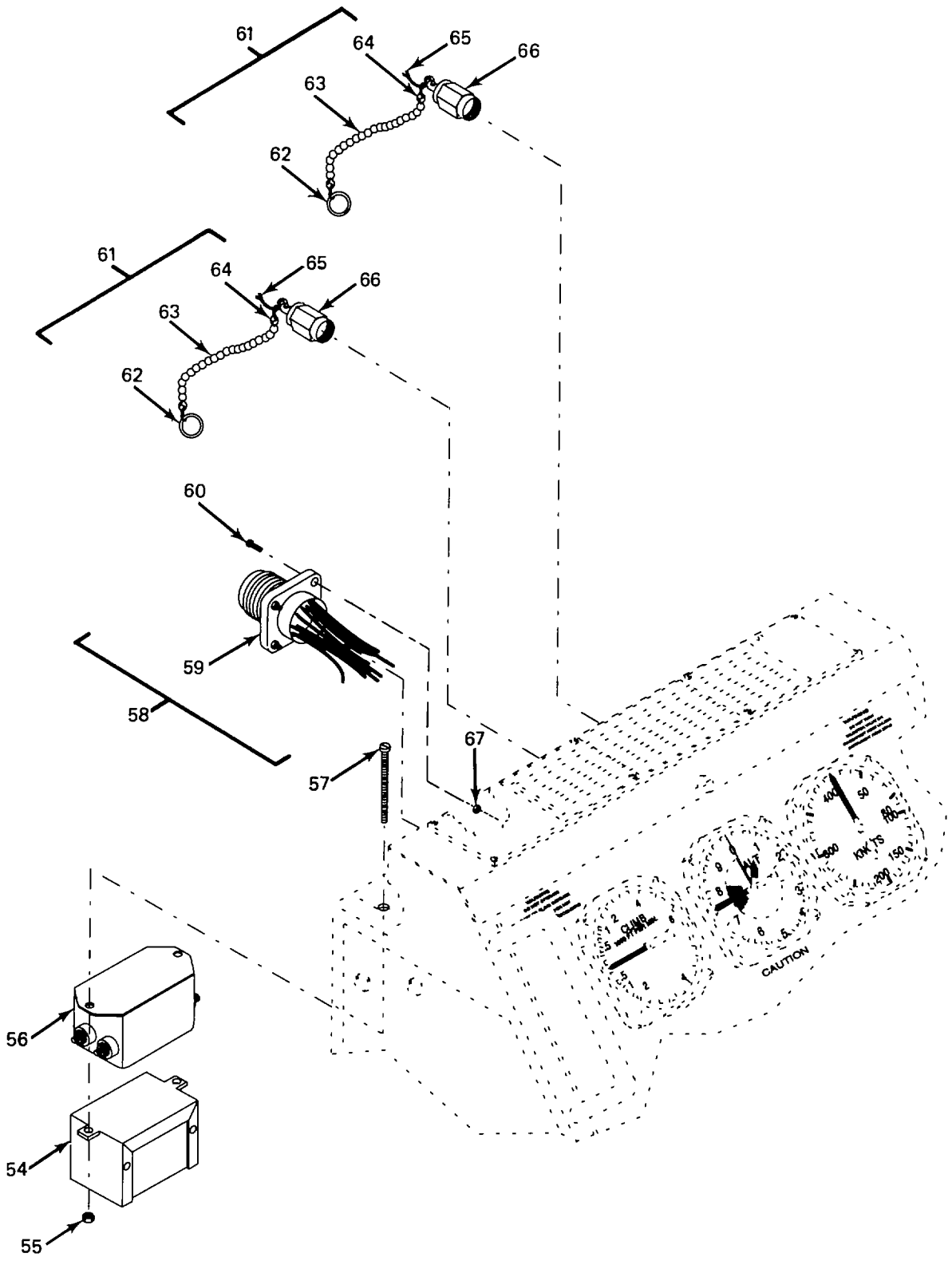

FIGURE C-4. CHASSIS ASSEMBLY (90-50025) (SHEET 4 OF 8)

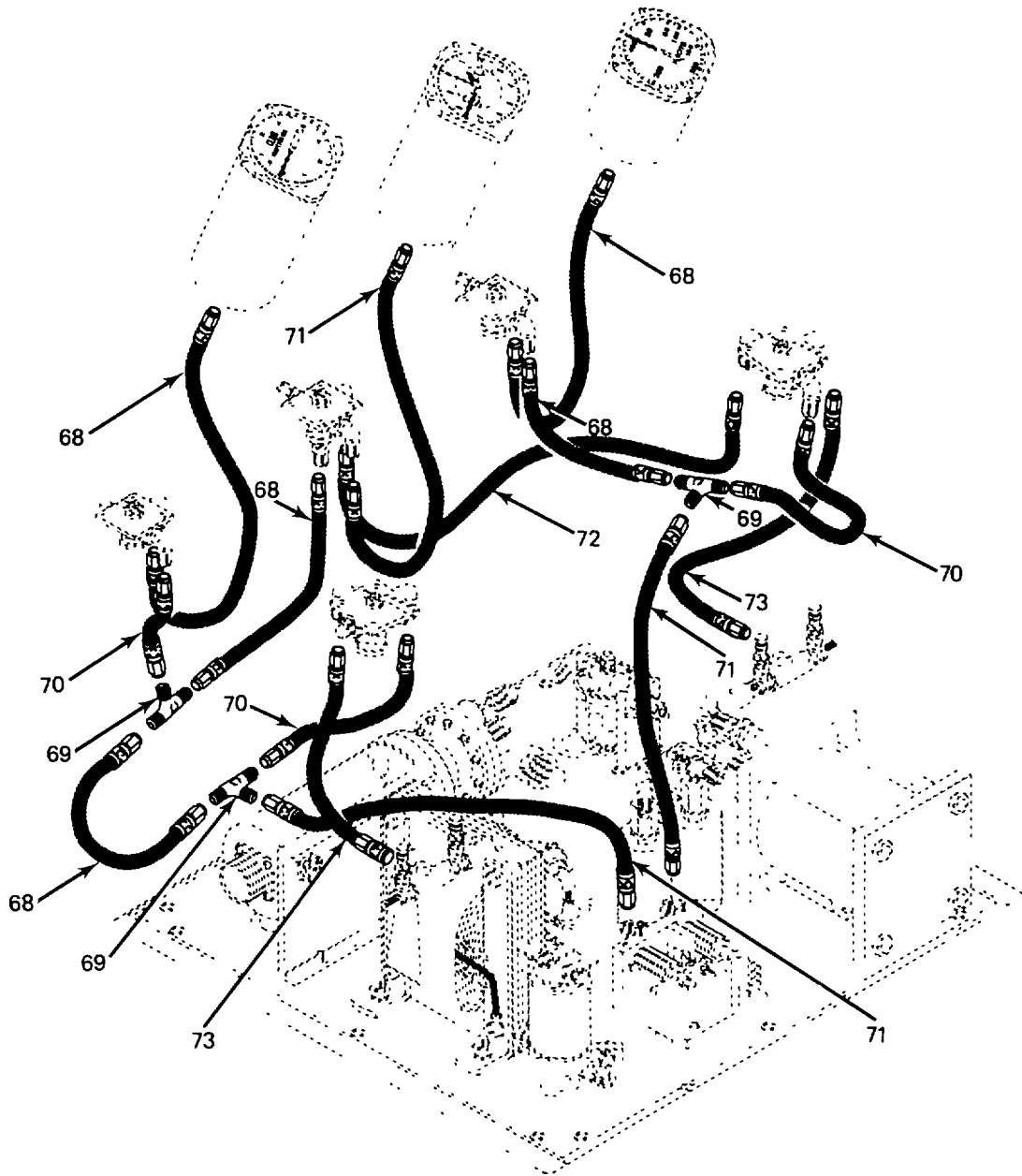

FIGURE C-4. CHASSIS ASSEMBLY (90-50025) (SHEET 5 OF 8)

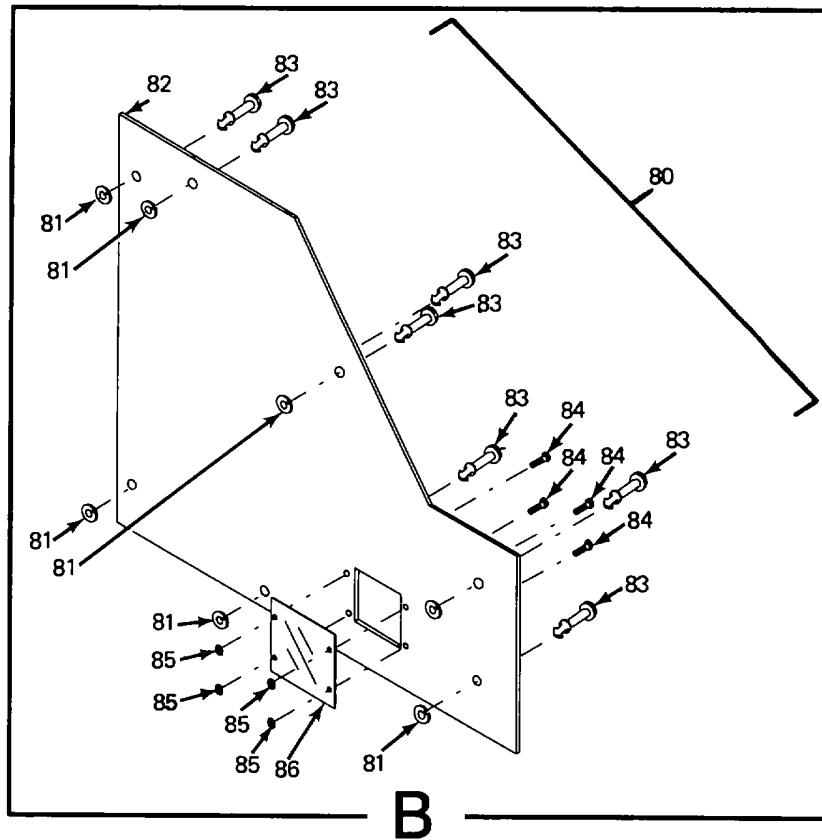
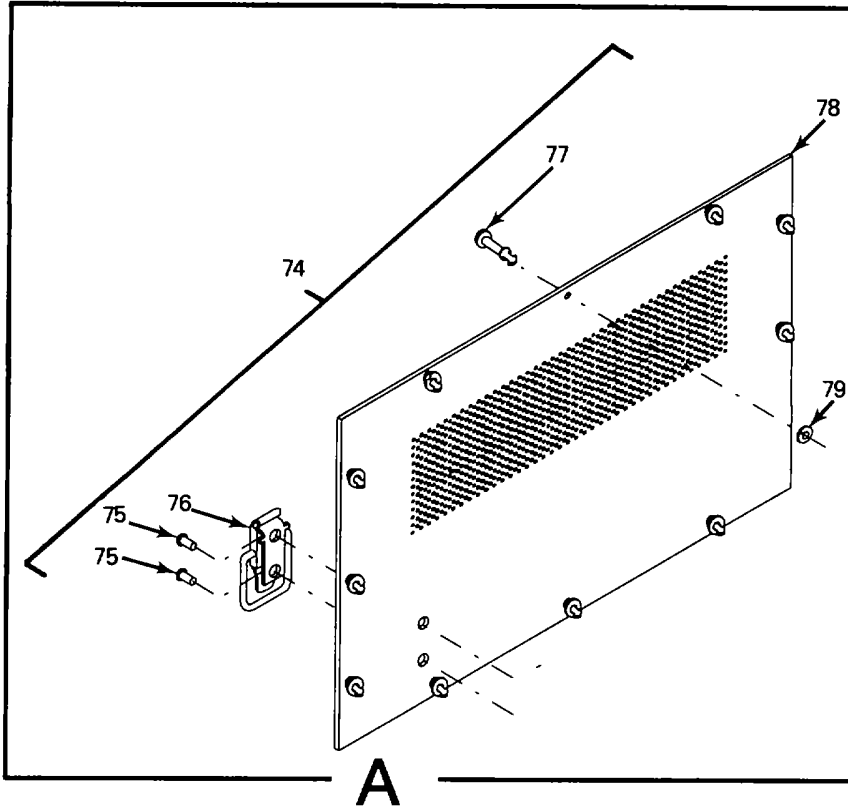

FIGURE C-4. CHASSIS ASSEMBLY (90-50025) (SHEET 6 OF 8)
C-23

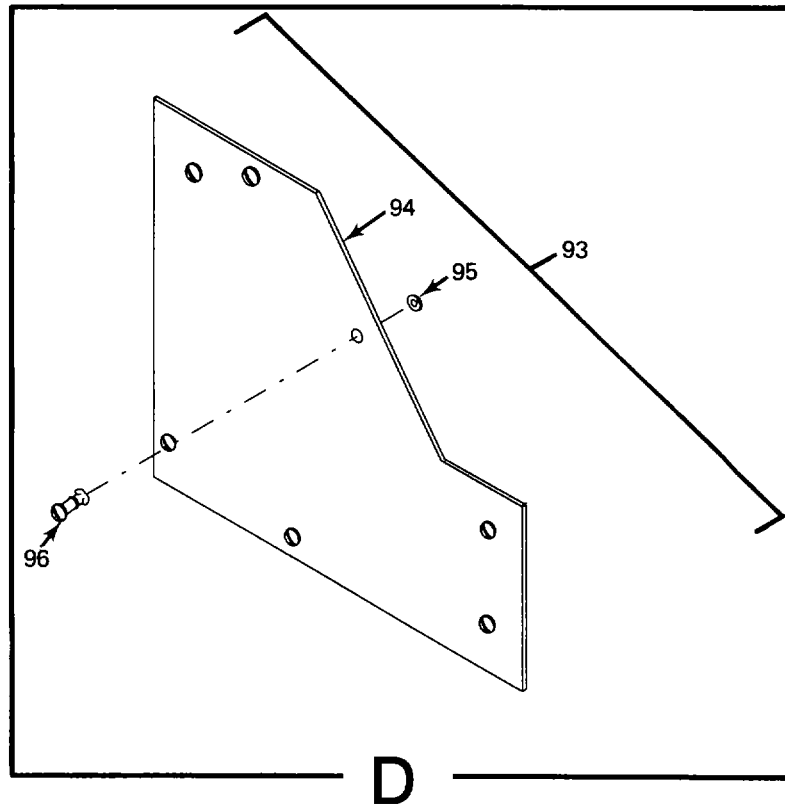
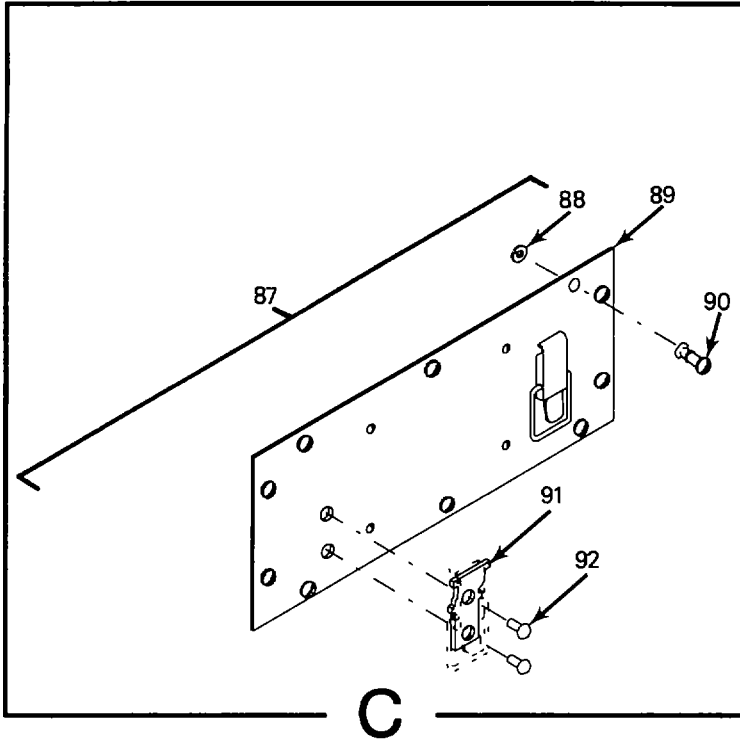

FIGURE C-4. CHASSIS ASSEMBLY (90-50025) (SHEET 7 OF 8)

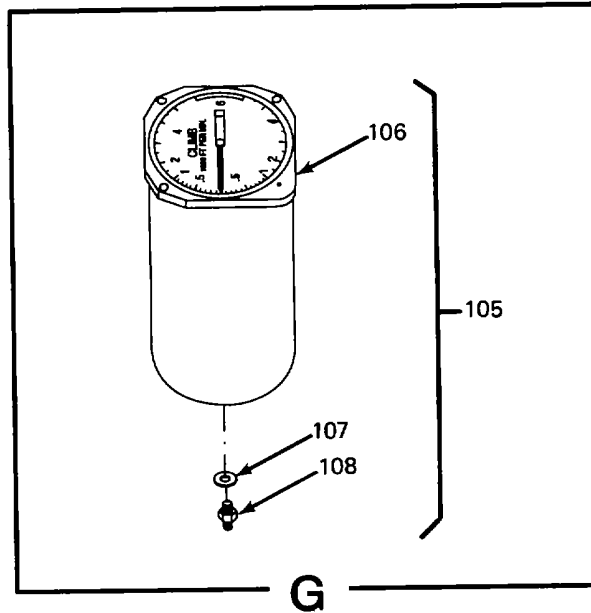
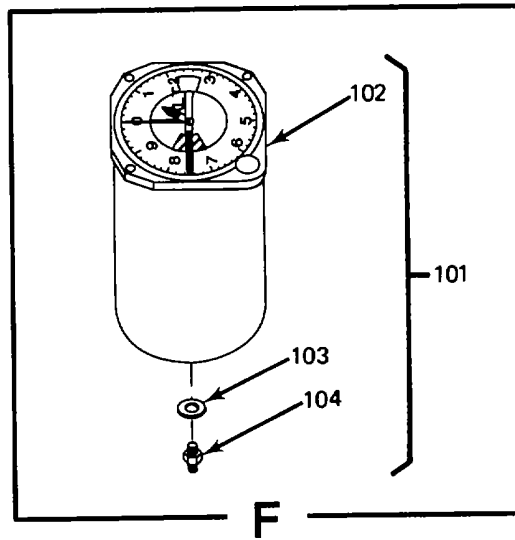
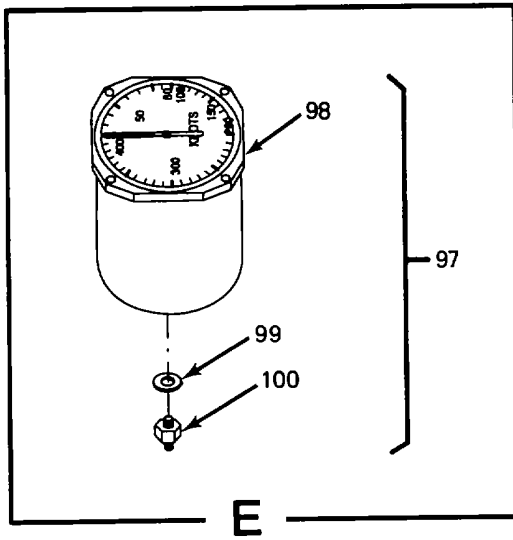

FIGURE C-4. CHASSIS ASSEMBLY (90-50025) (SHEET 8 OF 8)

(1) ITEM NO	(2) SMR CODE	(3) CAGE	(4) PART NUMBER	(5) DESCRIPTION AND USABLE ON CODES(UOC) QTY	(6)
GROUP: 0108 FIGURE C-4. CHASSIS ASSEMBLY (90-50025)					
1	XBFZZ	59413	62-10066	COVER, FRONT.....	1
2	XBFZZ	59413	55-10079	SCREW, MACHINE	12
3	XBFZZ	59413	98-10015	CORRECTION CARD	1
4	XBFZZ	59413	47-10004	NUT, HEXAGON	4
5	XBFZZ	59413	15-10034-1	ID PLATE	1
6	XBFFF	59413	91-10004	BOTTOM PLATE ASSY (SEE FIGURE C-5)	1
7	PAFZZ	96906	MS51957-27	SCREW, MACHINE	12
8	XBFZZ	59413	62-10053	FRAME ASSEMBLY	1
9	PAFZZ	96906	MS35649-264	NUT.....	12
10	PAFZZ	88044	AN515C6-4	SCREW, MACHINE	12
11	PAFZZ	88044	AN515B6-16	SCREW.....	10
12	PAFZZ	96906	MS35649-265	NUT, PLAIN HEXAGON	10
13	XBFFF	59413	14-10014	AIRSPD VALVE	1
14	PAFZZ	88044	AN816-4D	.ADAPTER, STRAIGHT.....	1
15	PAFZZ	88044	AN910-1D	.COUPLING, PIPE	1
16	PAFZZ	88044	AN911-1D	.NIPPLE, PIPE	1
17	XBFZZ	59413	14-10013	VALVE.....	1
18	PAFZZ	88044	AN822-3D	.ELBOW, FLARED	2
19	XBFFF	59413	14-10016	ALTIMETER SELECTOR	1
20	PAFZZ	88044	AN816-4D	.ADAPTER, STRAIGHT.....	1
21	PAFZZ	88044	AN910-1D	.COUPLING, PIPE	1
22	PAFZZ	88044	AN911-1D	.NIPPLE, PIPE	1
23	XBFZZ	59413	14-10015	VALVE.....	1
24	XBFZZ	88044	AN816-4D	.ADAPTER, STRAIGHT.....	1
25	PAFZZ	88044	AN822-3D	.ELBOW, FLARED	2
26	XBFFF	59413	14-10010	RATE OF CLIMB	1
27	PAFZZ	88044	AN913-1D	PLUG	1
28	XBFZZ	59413	14-10009	.VALVE	1
29	PAFZZ	88044	AN822-3D	.ELBOW, FLARED	2
30	XBFZZ	59413	66-10084	FUSE	2
31	XBFZZ	59413	92-10130	FUSE HOLDER, SPARE	1
32	XBFZZ	59413	66-10083	FUSE HOLDER	1
33	PAFZZ	96906	MS25237-327	LAMP	1
34	PAFZZ	96906	MS25041-7	LIGHT ASSEMBLY	1
35	PAFZZ	88044	AN515C6-4	SCREW, MACHINE	8
36	XBFFF	59413	92-10128	METERING VALVE	1
37	PAFZZ	88044	AN916-1D	.ELBOW, PIPE	1
38	XBFZZ	59413	14-10007	METERING VALVE	2
39	PAFZZ	88044	AN917-1D	.TEE, PIPE	1
40	PAFZZ	88044	AN816-3D	.ADAPTER, STRAIGHT.....	2
41	XBFFF	59413	92-10129	METERING VALVE	1
42	XBFZZ	59413	14-10007	METERING VALVE	2
43	PAFZZ	88044	AN917-1D	TEE, PIPE	1
44	PAFZZ	88044	AN916-1D	.ELBOW, PIPE	1
45	PAFZZ	88044	AN816-3D	.ELBOW, FLARED	2

(1) ITEM NO	(2) SMR CODE	(3) CAGE	(4) PART NUMBER	(5) DESCRIPTION AND USABLE ON CODES(UOC)	(6) QTY
46	PAFZZ	96906	MS35059-22	SWITCH, TOGGLE	1
47	XBFFF	59413	14-10012	VACUUM SELECTOR	1
48	PAFZZ	88044	AN822-3D	.ELBOW, FLARED	2
49	XBFZZ	59413	14-10001	.VALVE.....	1
50	PAFZZ	88044	AN913-ID	.PLUG	1
51	XBFFF	59413	14-10011	PRESSURE SELECTOR	1
52	XBFZZ	59413	14-10001	.VALVE.....	1
53	PAFZZ	88044	AN822-3D	.ELBOW, FLARED	3
54	XBFZZ	59413	98-10011	EMI FILTER, LOW PASS	1
55	PAFZZ	96906	M535649-264	NUT	2
56	XBFZZ	59413	66-10095	EMI FILTER	1
57	PAFZZ	96906	M535233-38	SCREW, MACHINE	2
58	XBFFF	59413	92-10116	HARNES ASSEMBLY	1
59	PAFZZ	96906	M53102R18-1P	.CONNECTOR	1
60	PAFZZ	96906	M535233-17	SCREW, MACHINE	4
61	XBFFF	59413	62-10073	CAP ASSEMBLY, PRESSURE	2
62	XBFZZ	59413	62-10074	.RING, KEY	1
63	XBFZZ	59413	62-10075	.CHAIN, KEY	1
64	XBFZZ	59413	62-10076	.COUPLING	2
65	XBFZZ	59413	80-10145	.WIRE, SAFETY	1
66	PAFZZ	88044	AN929A4D	CAP	1
67	XBFZZ	59413	42-10010	NUT, PLAIN HEXAGON	4
68	PAFZZ	88044	AN6270-3D0100	HOSE ASSEMBLY	5
69	PAFZZ	88044	AN824-3D	TUBE, TEE FLARED	3
70	XBFZZ	88044	AN6270-3-0030	HOSE ASSEMBLY	3
71	PAFZZ	88044	AN6270-3-120	HOSE ASSEMBLY	3
72	PAFZZ	88044	AN6270-3D0180	HOSE ASSEMBLY	1
73	PAFZZ	88044	AN6270-3D0150	HOSE ASSEMBLY	2
74	XBFFF	59413	92-10137	PLATE ASSY, BACK	1
75	PAFZZ	96906	MS20470A4-6	.RIVET.....	4
76	XBFZZ	59413	51-10016	.CATCH.....	2
77	XBFZZ	59413	51-10015	.FASTENER	12
78	XBFZZ	59413	62-10051	.PLATE, BACK	1
79	XBFZZ	59413	51-10013	.RING, SNAP	12
80	XBFFF	59413	92-10135	DOOR ASSEMBLY, RIGHT	1
81	XBFZZ	59413	51-10013	.RING, SNAP	7
82	XBFZZ	59413	62-10059-2	.DOOR, RIGHT	1
83	XBFZZ	59413	51-10015	.FASTENER	7
84	XBFZZ	59413	55-10078	.SCREW, MACHINE	4
85	XBFZZ	59413	47-10014	.NUT, HEXAGON	4
86	XBFZZ	59413	16-10010	.WINDOW, RIGHT DOOR	1
87	XBFFF	59413	92-10136	DOOR ASSY, FRONT	1
88	XBFZZ	59413	51-10013	.RING, SNAP	10
89	XBFZZ	59413	35-10045	.DOOR, FRONT	1
90	XBFZZ	59413	51-10015	.FASTENER	10
91	XBFZZ	59413	51-10016	.CATCH.....	2
92	PAFZZ	96906	MS20470A4-6	.RIVET.....	4
93	XBFFF	59413	92-10141	DOOR ASSEMBLY, LEFT	1
94	XBFZZ	59413	62-10059-1	.DOOR, LEFT	1
95	XBFZZ	59413	51-10013	.RING, SNAP	7

(1) ITEM NO	(2) SMR CODE	(3) CAGE	(4) PART NUMBER	(5) DESCRIPTION AND USABLE ON CODES(UOC) QTY	(6)
96	XBFZZ	59413	51-10015	.FASTENER	7
97	XBFFF	59413	92-10132	INDICATOR AIRSPEED	1
98	PAFZZ	96906	MS28046T1	.INDICATOR, AIRSPEED	1
99	PAFZZ	88044	AN6227-6	.PACKING, PREFORMED	1
100	PAFZZ	88044	AN919-2D	.REDUCER, FLARED	1
101	XBFFF	59413	92-10133	INDICATOR, ALTIMETER	1
102	PAFZZ	81349	AAU-31/A	.INDICATOR, ALTIMETER	1
103	PAFZZ	88044	AN6227-6	.PACKING, PREFORMED	1
104	PAFZZ	88044	AN919-2D	.REDUCER, FLARED	1
105	XBFFF	59413	92-10134	INDICATOR, RATE OF	1
106	PAFZZ	96906	MS25454-5	.INDICATOR, RATE	1
107	PAFZZ	88044	AN6227-6	.PACKING, PREFORMED	1
108	PAFZZ	88044	AN816-3	.ADAPTER, STRAIGHT	1

END OF FIGURE

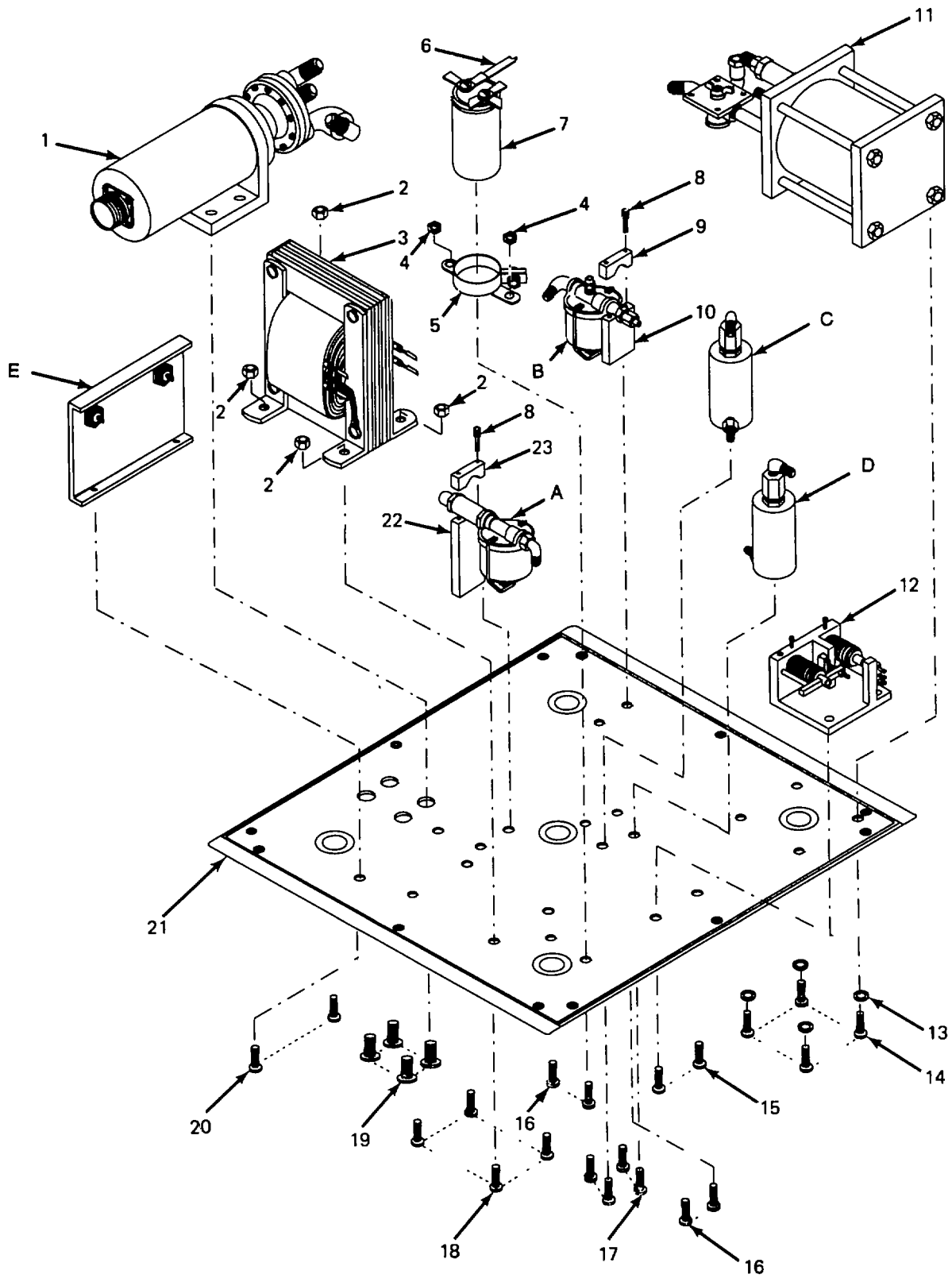

FIGURE C-5. BOTTOM PLATE ASSEMBLY (91-10004) (SHEET 1 OF 4)

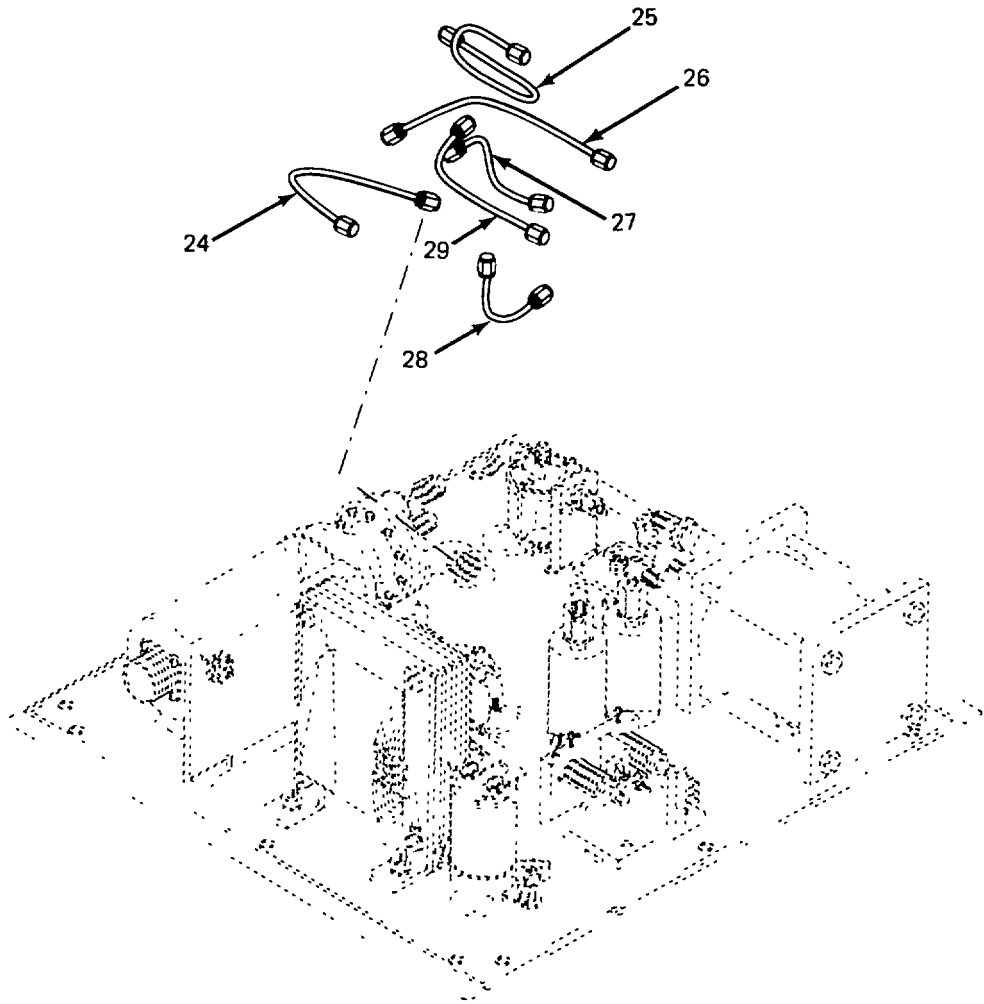

FIGURE C-5. BOTTOM PLATE ASSEMBLY (91-10004) (SHEET 2 OF 4)

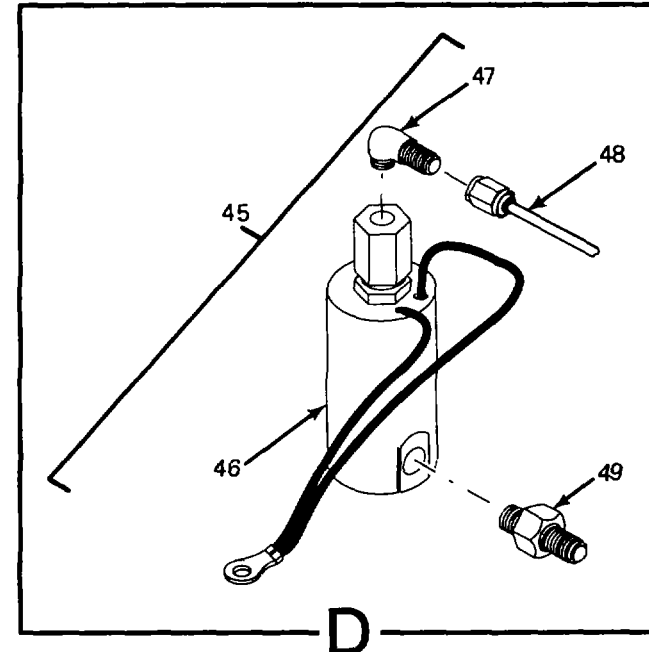
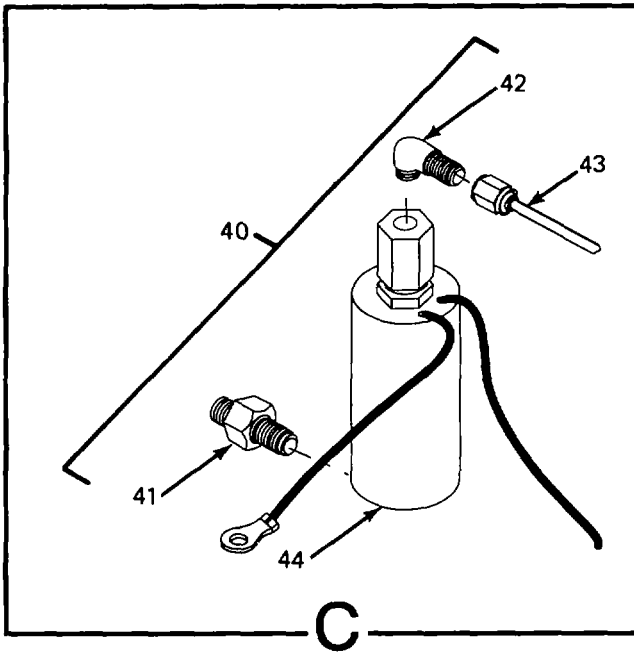
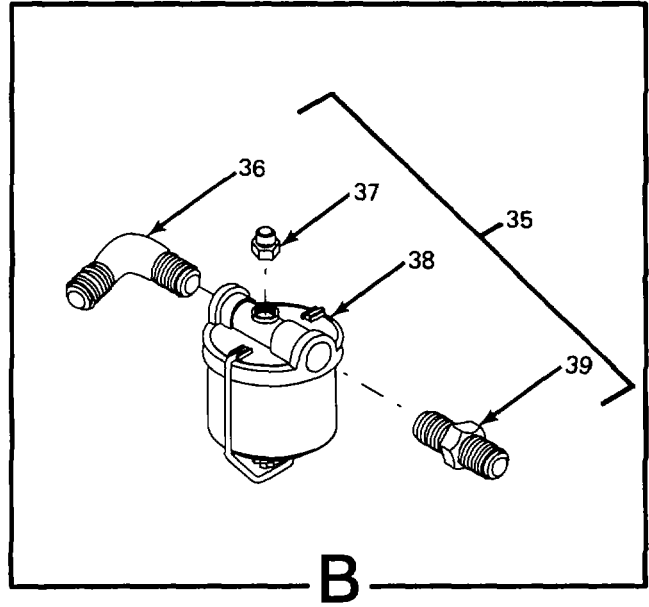
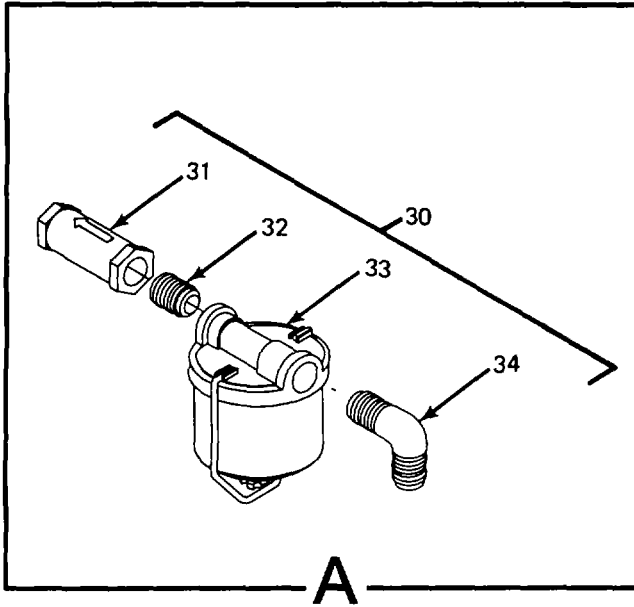
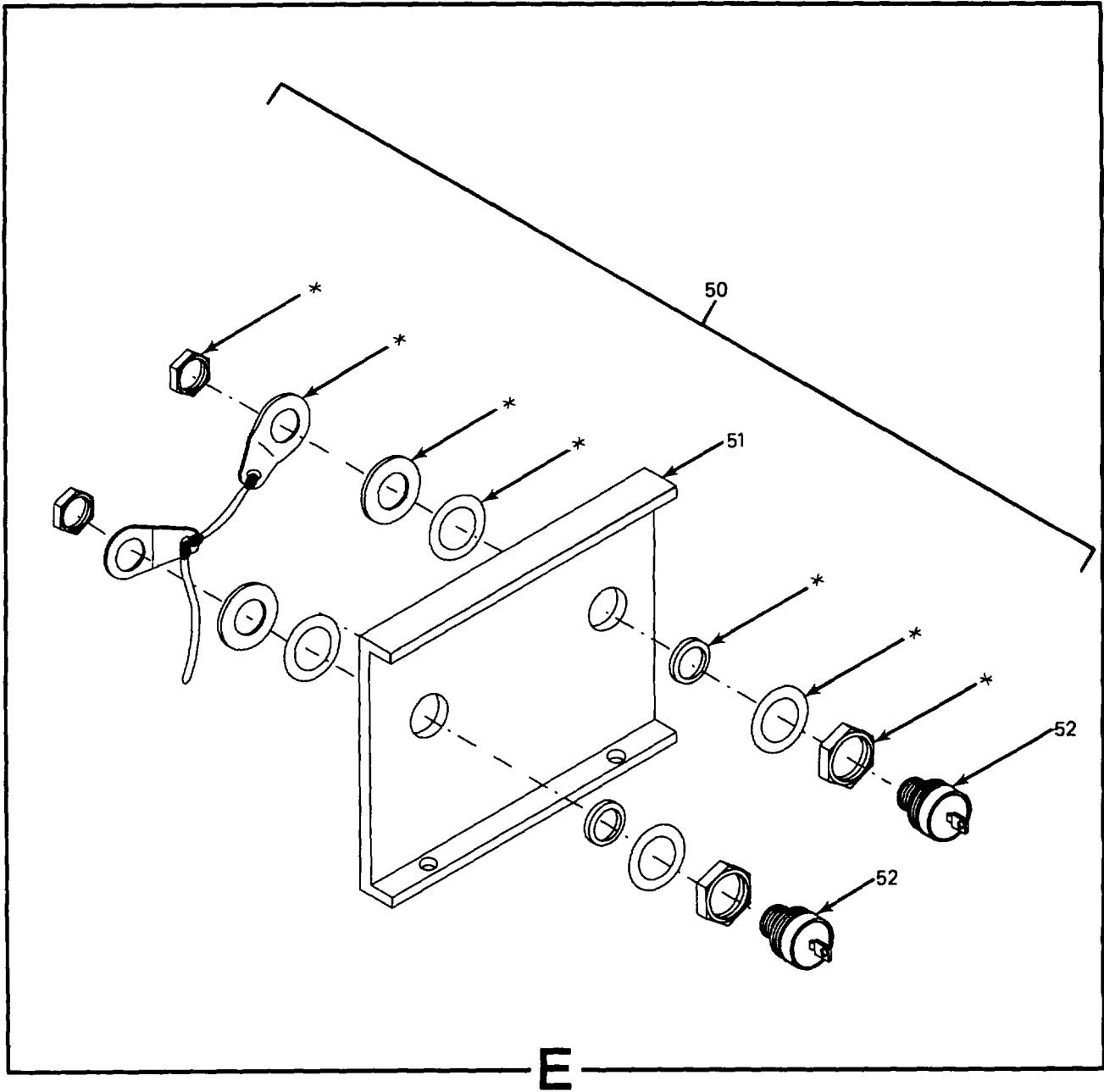

FIGURE C-5. BOTTOM PLATE ASSEMBLY (91-10004) (SHEET 3 OF 4)



*Finish with associated item

FIGURE C-5. BOTTOM PLATE ASSEMBLY (91-10004) (SHEET 4 OF 4)

(1) ITEM NO	(2) SMR CODE	(3) CAGE	(4) PART NUMBER	(5) DESCRIPTION AND USABLE ON CODES(UOC)	(6) QTY
GROUP 010814 FIGURE C-5. BOTTOM PLATE ASSEMBLY (91-10004)					
1	XBFFF	59413	92-0011	PUMP ASSEMBLY (SEE FIGURE C-7).....	1
2	PAFZZ	96906	MS35649-284	NUT,PLAIN HEXAGON	4
3	XBFZZ	59413	71-00003	TRANSFORMER	1
4	PAFZZ	96906	MS35649-264	NUT.....	2
5	XBFZZ	59413	60-10005	CLAMP.....	1
6	XBFZZ	59413	80-10129	WIRE,GROUND	1
7	XBFZZ	59413	70-10028	CAPACITOR	1
8	PAFZZ	96906	MS16995-40	SCREW,MACHINE	4
9	XBFZZ	59413	35-0025	CLAMP,BRACKET	1
10	XBFZZ	59413	35-0026	BRACKET,SUMP	1
11	XBFFF	59413	92-0003	RESERVOIR ASSEMBLY (SEE FIGURE C-6)	1
12	XBFFF	59413	92-0006	BELLOWS BLOCK ASSY (SEE FIGURE C-8)	1
13	PAFZZ	96906	MS35338-41	WASHER,LOCK	4
14	PAFZZ	96906	MS35233-28	SCREW,MACHINE	4
15	PAFZZ	88044	AN515C8-4	SCREW,MACHINE	2
16	PAFZZ	96906	MS35231-26	SCREW,MACHINE	6
17	PAFZZ	96906	MS35234-59	SCREW,MACHINE	4
18	PAFZZ	88044	AN500D8-9	SCREW,MACHINE	4
19	PAFZZ	96906	MS35223-75	SCREW,MACHINE	4
20	PAFZZ	96906	MS35233-26	SCREW,MACHINE	2
21	XBFZZ	59413	62-10057	PLATE,BOTTOM	1
22	XBFZZ	59413	35-0017	BRACKET,SUMP	1
23	XBFZZ	59413	35-0019	CLAMP,BRACKET	1
24	XBFZZ	59413	11-10006-4	TUBE FITTING ASSY	1
25	XBFZZ	59413	11-10006-6	TUBE FITTING ASSY	1
26	XBFZZ	59413	11-10006-5	TUBE FITTING ASSY	1
27	XBFZZ	59413	11-10006-1	TUBE FITTING ASSY	1
28	XBFZZ	59413	11-10006-3	TUBE FITTING ASSY	1
29	XBFZZ	59413	11-10006-2	TUBE FITTING ASSY	1
30	XBFFF	59413	92-0012	FILTER ASSEMBLY	1
31	XBFZZ	59413	14-10004	.VALVE,CHECK	1
32	PAFZZ	88044	AN816-3D	ADAPTER, STRAIGHT	1
33	XBFZZ	59413	66-10097	.FILTER,MODIFIED	1
34	PAFZZ	88044	AN822-3D	.ELBOW,FLARED	2
35	XBFFF	59413	66-10098	FILTER ASSEMBLY	1
36	PAFZZ	88044	AN816-3D	.ELBOW,FLARED	1
37	XBFZZ	59413	14-10006	.VALVE,RELIEF	1
38	XBFZZ	59413	66-10096	.FILTER,MODIFIED	1
39	PAFZZ	88044	AN822-3D	.ADAPTER,STRAIGHT	1
40	XBFFF	59413	92-0010	SOLENOID VALVE	1
41	PAFZZ	88044	AN822-3D	.ADAPTER,STRAIGHT	1
42	PAFZZ	88044	AN816-3D	.ELBOW,FLARED	1
43	XBFZZ	59413	11-10006-7	.TUBE FITTING ASSY	1
44	XBFZZ	59413	14-10005	.VALVE,SOLENOID	1
45	XBFFF	59413	92-0009	SOLENOID VALVE	1

(1) ITEM NO	(2) SMR CODE	(3) CAGE	(4) PART NUMBER	(5) DESCRIPTION AND USABLE ON CODES(UOC) QTY	(6)
46	XBFZZ	59413	14-10005	.VALVE, SOLENOID	1
47	PAFZZ	88044	AN816-3D	.ELBOW,FL ARED	1
48	XBFZZ	59413	11-10006-7	.TUBE FITTING ASSY	1
49	PAFZZ	88044	AN822-3D	.ADAPTER, STRAIGHT	1
50	XBFFF	59413	92-0005	DIODE PLATE ASSEMB	1
51	XBFZZ	59413	35-0014	.DIODE PLATE	1
52	XBFZZ	59413	74-10013	.DIODE	2

END OF FIGURE

This Page Intentionally Left Blank

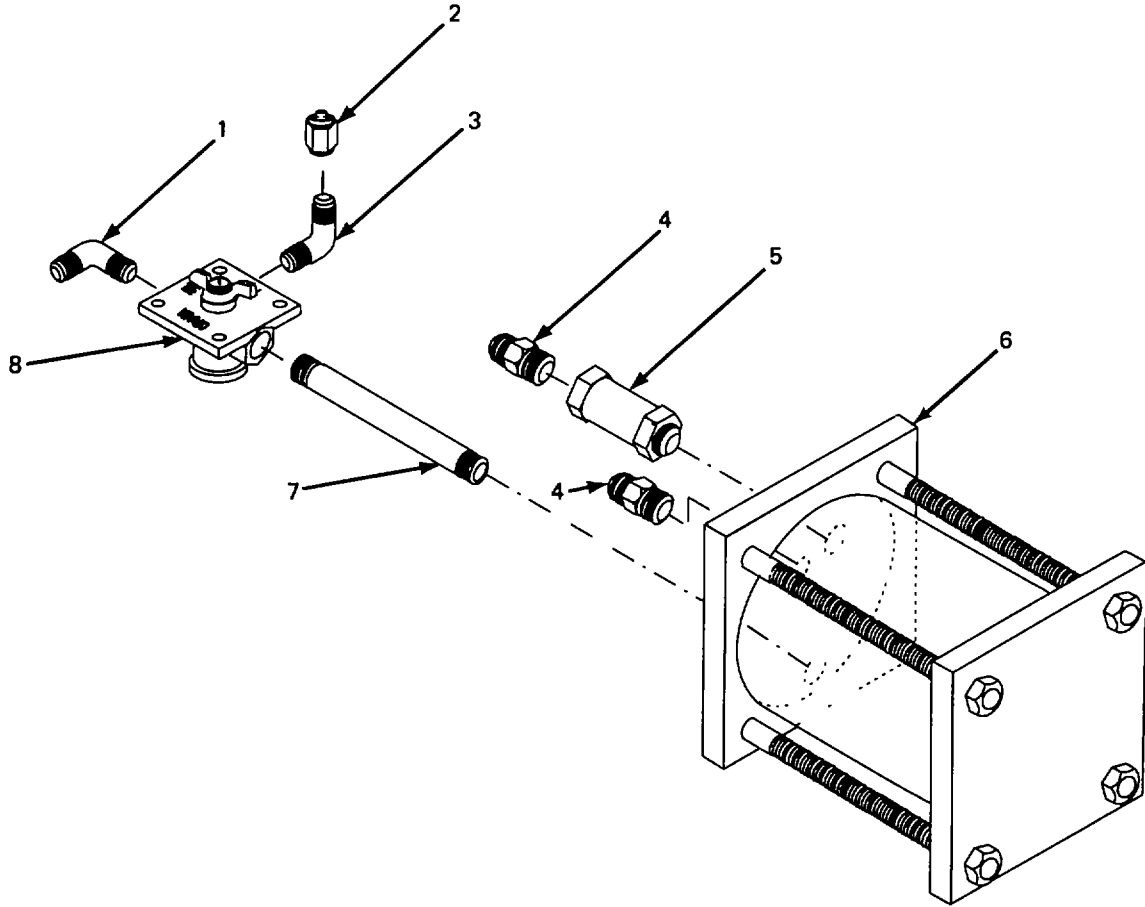

FIGURE C-6. RESERVOIR ASSEMBLY

(1) ITEM NO	(2) SMR CODE	(3) CAGE	(4) PART NUMBER	(5) DESCRIPTION AND USABLE ON CODES(UOC)	(6) QTY
GROUP 01081401 FIGURE C-6. RESERVOIR ASSEMBLY (92-0003)					
1	PAFZZ	88044	AN823-3D	ELBOW, FLARED	1
2	PAFZZ	88044	AN929-3	CAP ASSEMBLY	1
3	PAFZZ	88044	AN822-3D	ELBOW, FLARED	1
4	PAFZZ	88044	AN816-3D	ADAPTER, STRAIGHT	2
5	XBFZZ	59413	14-10004	VALVE, CHECK.....	1
6	XBFFF	59413	92-0008	RESERVOIR SUBASSY	1
7	XBFZZ	59413	12-10006	NIPPLE, 1/8 PIPE	1
8	XBFZZ	59413	14-10002	VALVE, SELECTOR	1

END OF FIGURE

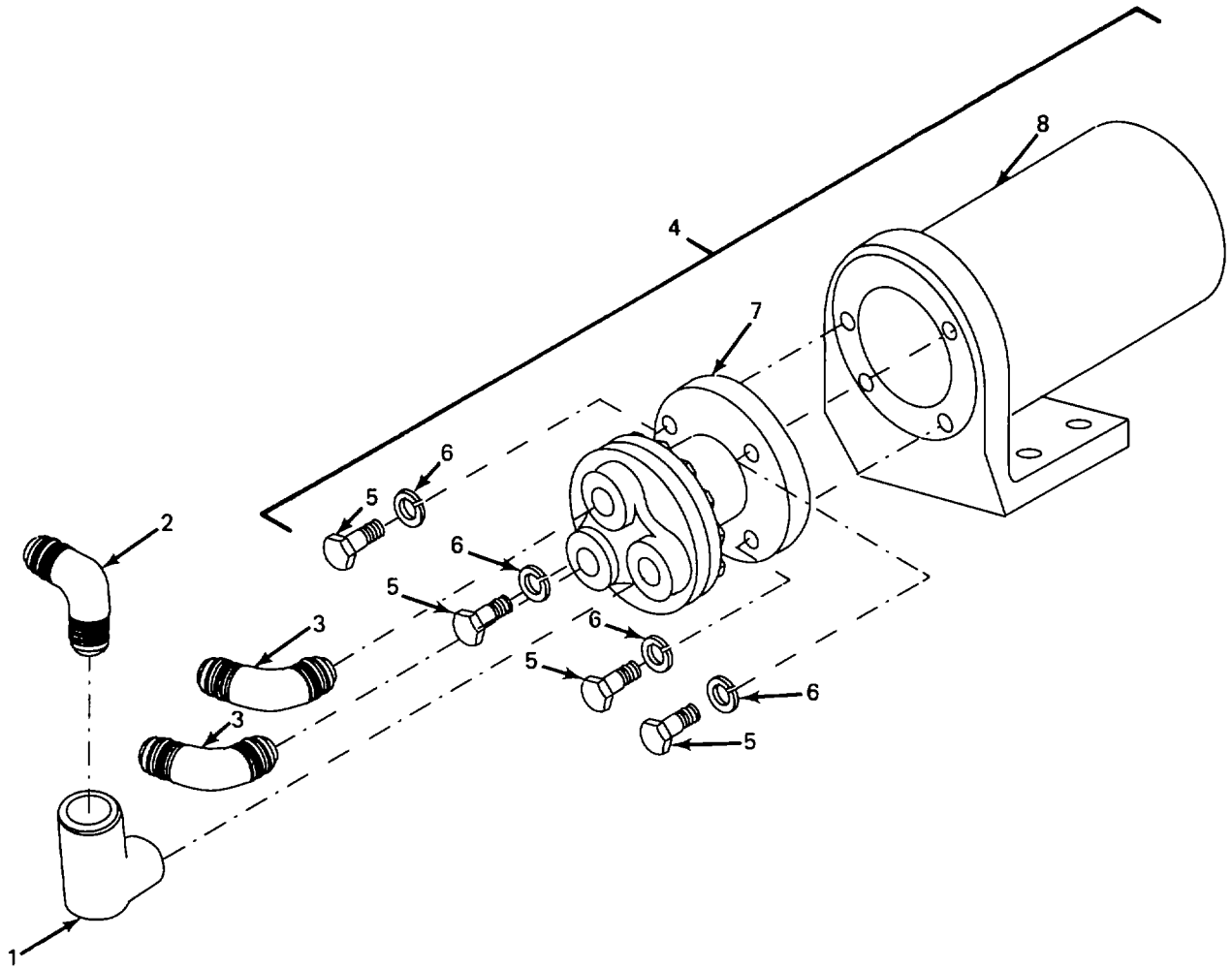

FIGURE C-7. PUMP ASSEMBLY (92-0011)

(1) ITEM NO	(2) SMR CODE	(3) CAGE	(4) PART NUMBER	(5) DESCRIPTION AND USABLE ON CODES(UOC)	(6) QTY
GROUP 01081402 FIGURE C-7. PUMP ASSEMBLY (92-0011)					
1	PAFZZ	88044	AN914-1D	ELBOW,INTERNAL,EXT	1
2	PAFZZ	88044	AN822-3D	ELBOW,FLARED	1
3	PAFZZ	88044	AN823-3D	ELBOW,FLARED ..	2
4	XBFFF	59413	17-10002	PUMP,MOTOR ASSY	1
5	PAFZZ	59413	P-115-A	.SCREW	4
6	XBFZZ	59413	3005-5	.WASHER,LOCK	4
7	XBFZZ	59413	P-345	.PUMP ASSEMBLY	1
8	XBFZZ	59413	10127	.MOTOR,ELECTRIC	1

END OF FIGURE

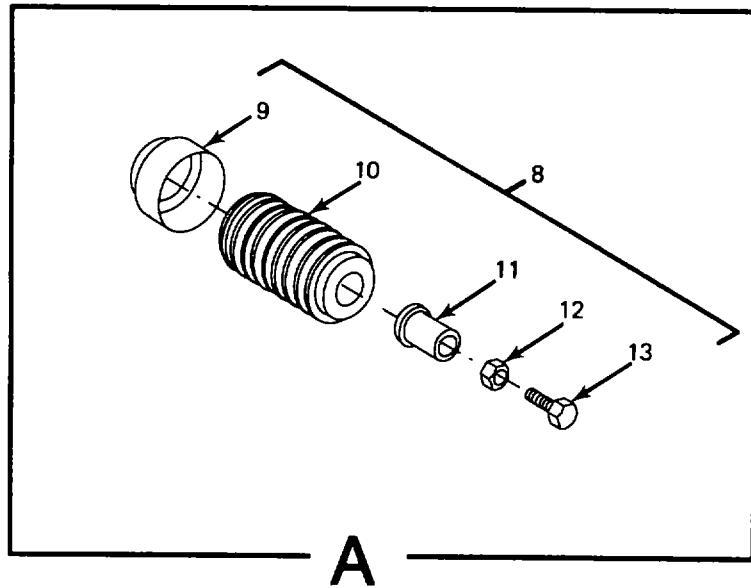
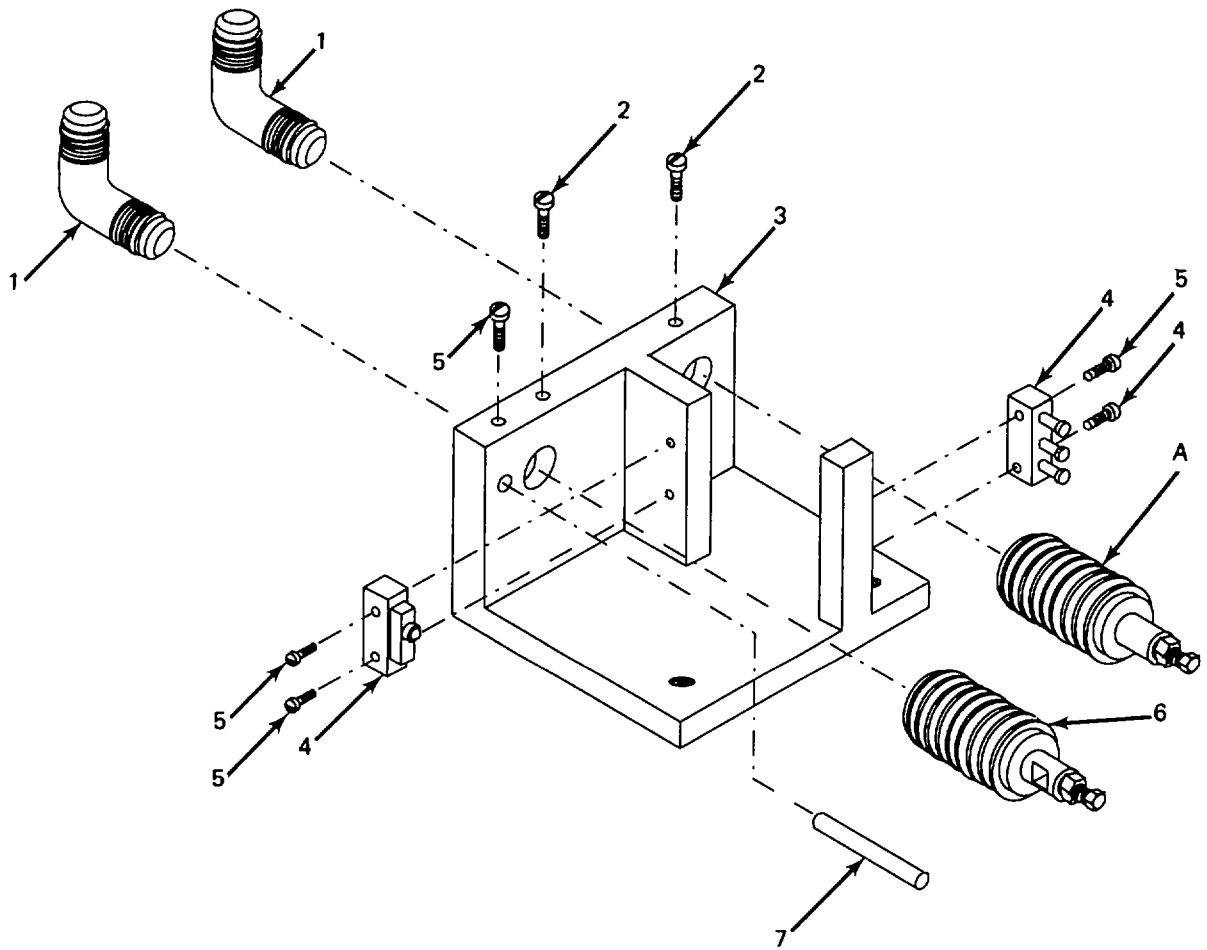

FIGURE C-8. BELLOWS BLOCK ASSEMBLY (92-0006)
C-40

(1) ITEM NO	(2) SMR CODE	(3) CAGE	(4) PART NUMBER	(5) DESCRIPTION AND USABLE ON CODES(UOC)	(6) QTY
GROUP 01081404 FIGURE C-8. BELLOWS BLOCK ASSEMBLY (92-0006)					
1	PAFZZ	88044	AN822-3D	ELBOW,FLARED	2
2	PAFZZ	88044	AN500D8-9	SCREW,MACHINE	2
3	XBFZZ	59413	35-0015	BLOCK,BELLOW	1
4	XBFZZ	59413	79-10006	MICROSWITCH	2
5	PAFZZ	88044	AN501D3-3	SCREW,MACHINE	5
6	XBFZZ	59413	92-10120	BELLOW ASSY,VACUUM	1
7	XBFZZ	59413	62-10050	STOP,BELLOW	1
8	XBFFF	59413	92-10119	BELLOWS ASSY,PRESSU	1
9	XBFZZ	59413	23-10003	.COUPLING,BELLOWS	1
10	XBFZZ	59413	23-10006	.BELLOW.....	1
11	XBFZZ	59413	23-10005	.BUTTON,BELLOWS	1
12	PAFZZ	96906	MS35649-224	.NUT,PLAIN,HEXAGON	1
13	XBFZZ	59413	35-10040	.SCREW,MACHINE	1

END OF FIGURE

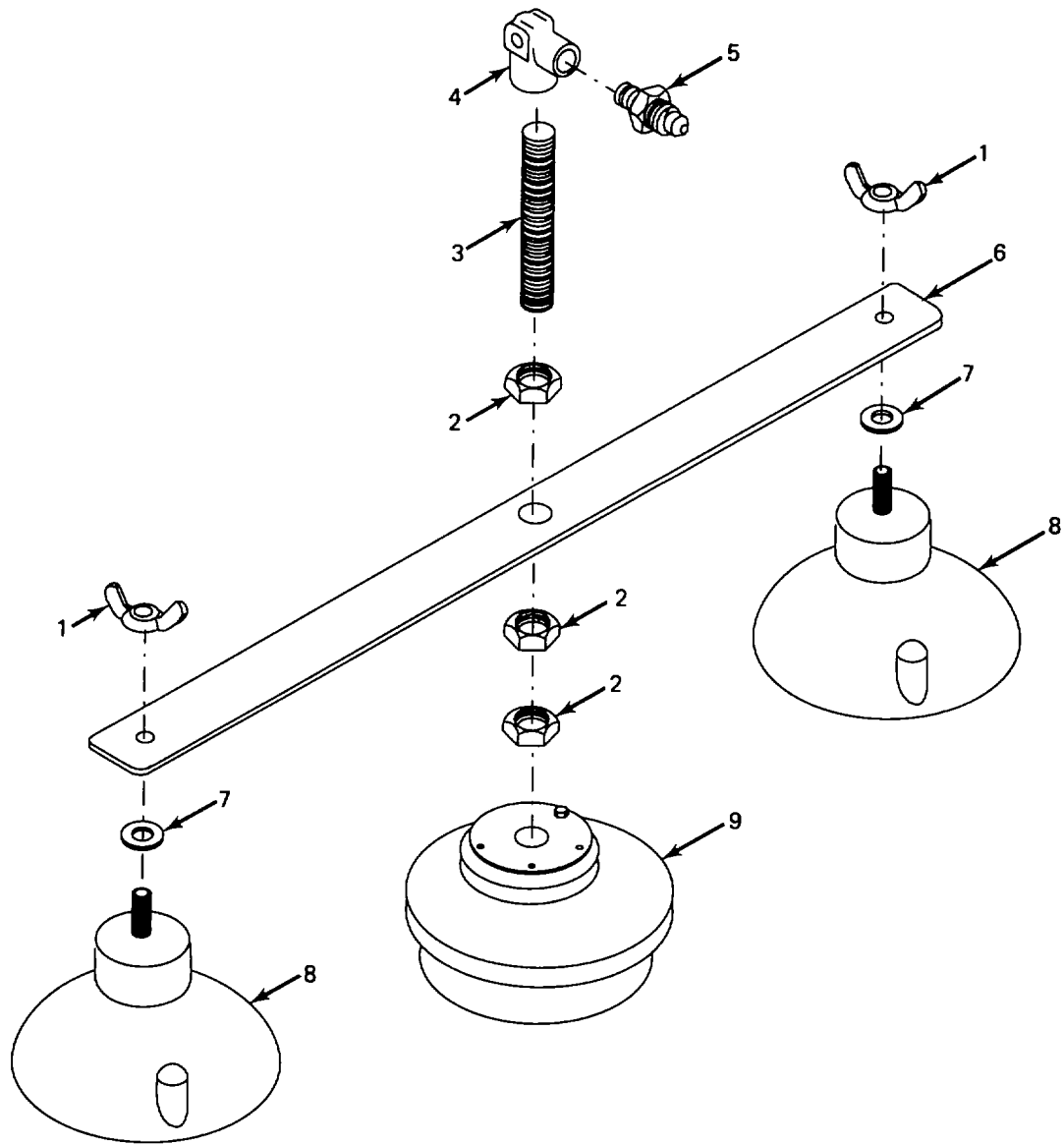

FIGURE C-9. STATIC CLAMP ASSEMBLY (92-10113)

(1) ITEM NO	(2) SMR CODE	(3) CAGE	(4) PART NUMBER	(5) DESCRIPTION AND USABLE ON CODES(UOC)	(6) QTY
GROUP 0101 FIGURE C-9. CLAMP ASSEMBLY, STATIC (92-10113)					
1	PAFZZ	96906	MS35425-70	NUT,WING	2
2	XBFZZ	59413	47-10015	NUT,NPT	3
3	XBFZZ	59413	12-10005	TUBING.....	1
4	PAFZZ	88044	AN916-1D	ELBOW,PIPE	1
5	PAFZZ	88044	AN816-4D	ADAPTER,STRAIGHT	1
6	XBFZZ	59413	35-10010	PLATE,STATIC.....	1
7	PAFZZ	96906	MS27183-17	WASHER,FLAT.....	1
8	XBFZZ	59413	21-10002	SUCTION CUP,END	2
9	XBFZZ	59413	21-10001	SUCTION CUP,CENTER	1

END OF FIGURE

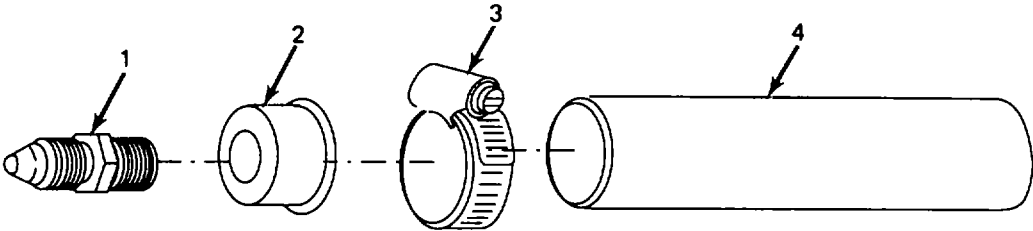

FIGURE C-10. PITOT CONNECTOR (92-10118)

(1) ITEM NO	(2) SMR CODE	(3) CAGE	(4) PART NUMBER	(5) DESCRIPTION AND USABLE ON CODES(UOC)	(6) QTY
GROUP 0102 FIGURE C-10. CONNECTOR, PITOT ASSEMBLY (92-10118)					
1	PAFZZ	88044	AN816-4D	ADAPTER,STRAIGHT.....	1
2	XBFZZ	59413	11-10003	ADAPTER,HOSE	1
3	PAFZZ	66295	AN737-TW26-34WWD	CLAMP,HOSE	1
4	XBFZZ	59413	11-10005	HOSE,RUBBER	1

END OF FIGURE

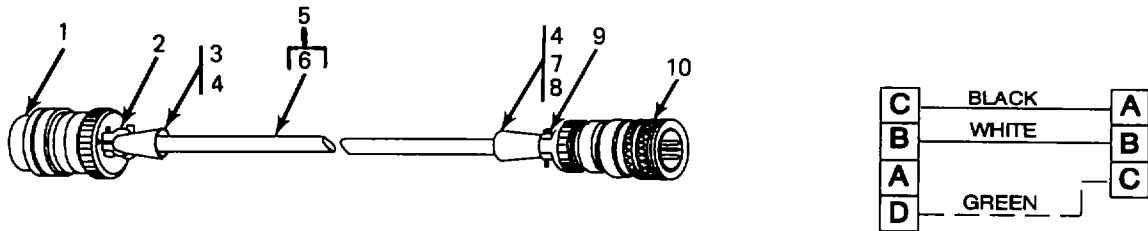
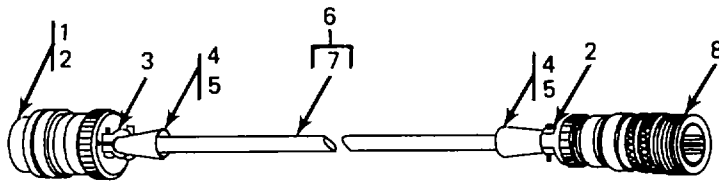

FIGURE C-11. 3 PHASE POWDER CORD ASSEMBLY (80-10112A)

(1) ITEM NO	(2) SMR CODE	(3) CAGE	(4) PART NUMBER	(5) DESCRIPTION AND USABLE ON CODES(UOC)	(6) QTY
GROUP 0103 FIGURE C-11 POWER CORD ASSEMBLY (80-10112A)					
1	PAFZZ	96906	MS3456W18-5S	CONNECTOR,PLUG	1
2	PAFZZ	81349	M85049/41-10A	CLAMP.....	1
3	PAFZZ	96906	MS3420-10	SLEEVE,INSULATOR	1
4	PAFZZ	96906	MS3420-6A	SLEEVE,INSULATOR	2
5	XBFFF	59413	80-10133A	CORD,10 INCH.....	1
6	XBFZZ	59413	80-10114A	CORD,ELECTRIC.....	1
7	PAFZZ	96906	MS3420-12	SLEEVE,INSULATOR	1
8	PAFZZ	96906	MS3420-8A	SLEEVE,INSULATOR.....	1
9	PAFZZ	81349	M85049/41-12A	CLAMP.....	1
10	PAFZZ	96906	MS3456W20-4P	CONNECTOR,PLUG.....	1

END OF FIGURE



NOTES:

1. CONNECT PINS "C" THROUGH "J" AS SHOWN IN THE WIRING SCHEMATIC.
USE BUSS WIRE , LENGTH AS REQUIRED.

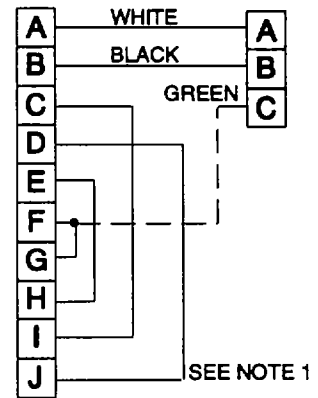

FIGURE C-12. A.C POWER CORD ASSEMBLY (80-10113A)

(1) ITEM NO	(2) SMR CODE	(3) CAGE	(4) PART NUMBER	(5) DESCRIPTION AND USABLE ON CODES(UOC)	(6) QTY
GROUP 0104 FIGURE C-12 POWER CORD ASSEMBLY (80-10113A)					
1	PAFZZ	96906	MS3456W18-1S	CONNECTOR,PLUG	1
2	XBFFF	59413	80-10128	WIRE,BUSS	1
3	PAFZZ	81349	M85049/41-10A	CLAMP	2
4	PAFZZ	96906	MS3420-6A	SLEEVE,INSULATOR	2
5	PAFZZ	96906	MS3420-10	SLEEVE,INSULATOR	1
6	XBFFF	59413	80-10130A	CORD,9 FT. 2 INCH	1
7	XBFFF	59413	80-10114A	.CORD,ELECTRIC	1
8	PAFZZ	96906	MS3456W18-5P	CONNECTOR, PLUG	1

END OF FIGURE

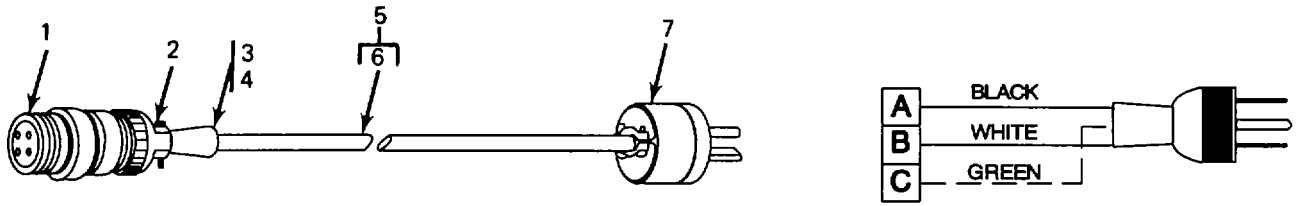
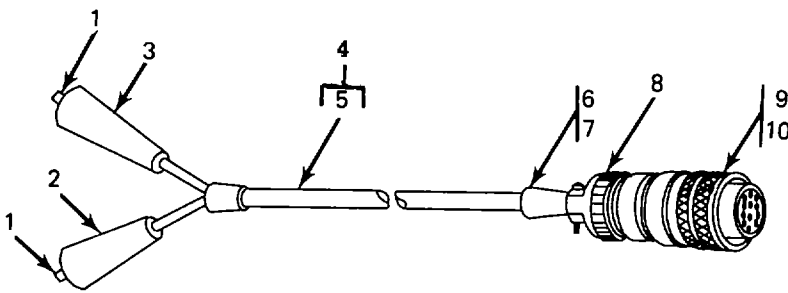

FIGURE C-13. A.C. POWER CORD ASSEMBLY (80-10110A)

(1) ITEM NO	(2) SMR CODE	(3) CAGE	(4) PART NUMBER	(5) DESCRIPTION AND USABLE ON CODES(UOC)	(6) QTY
GROUP 0105 FIGURE C-13. POWER CORD ASSEMBLY (80-10110A)					
1	PAFZZ	96906	MS3456W18-5S	CONNECTOR,PLUG	1
2	PAFZZ	81349	M85049/41-10A	CLAMP.....	1
3	PAFZZ	96906	MS3420-6A	SLEEVE,INSULATOR.....	1
4	PAFZZ	96906	MS3420-10	SLEEVE,INSULATOR	1
5	XBFFF	59413	80-10131A	CORD,ELECTRIC.....	1
6	XBFZZ	59413	80-10114A	.CORD,ELECTRIC.....	1
7	XBFZZ	59413	100-10015	PLUG,MALE.....	1

END OF FIGURE



NOTES:

1. CONNECT PINS AS SHOWN IN THE WIRING SCHEMATIC
USE BUSS WIRE LENGTH AS REQUIRED.

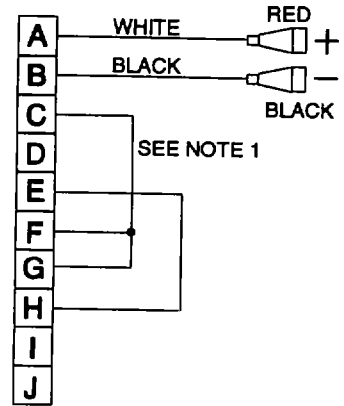

FIGURE C-14. POWER ADAPTER ASSEMBLY (80-10111)

(1) ITEM NO	(2) SMR CODE	(3) CAGE	(4) PART NUMBER	(5) DESCRIPTION AND USABLE ON CODES(UOC)	(6) QTY
GROUP 0106 FIGURE C-14 POWER ADAPTER ASSEMBLY (80-10111)					
1	XBFZZ	59413	100-10001	CLIP,BATTERY.....	2
2	XBFZZ	59413	100-10002	INSULATOR,RUBBER.....	1
3	XBFZZ	59413	100-10003	INSULATOR,RUBBER.....	1
4	XBFFF	59413	80-10132	CORD,8 FT 11.5 INCH.....	1
5	XBFZZ	59413	80-10114	.CORD,ELECTRIC.....	1
6	PAFZZ	96906	MS3420-10	SLEEVE,INSULATOR.....	1
7	PAFZZ	96906	MS3420-6A	SLEEVE,INSULATOR.....	1
8	PAFZZ	81349	M85049/41-10A	CLAMP.....	1
9	PAFZZ	96906	MS3456W18-1S	CONNECTOR,PLUG.....	1
10	XBFZZ	59413	80-10128	WIRE,BUSS.....	1

END OF FIGURE

CROSS-REFERENCE INDEXES
NATIONAL STOCK NUMBER INDEX

STOCK NUMBER	FIGURE	ITEM	STOCK NUMBER	FIGURE	ITEM
5305-00-045-1628	C-5	14	4730-00-187-0085	C-6	4
5310-00-045-4007	C-5	13	4730-00-187-0839	C-4	108
5305-00-054-6650	C-4	35	4730-00-187-1391	C-4	37
5305-00-054-6651	C-4	7	4730-00-187-1391	C-4	44
6210-00-143-6611	C-4	34	4730-00-187-1391	C-9	4
5305-00-151-0622	C-4	11	5330-00-196-5368	C-4	99
6240-00-155-7836	C-4	33	5330-00-196-5368	C-4	103
5930-00-166-2016	C-4	46	5330-00-196-5368	C-4	107
4730-00-186-7783	C-4	16	5935-00-199-2626	C-11	10
4730-00-186-7783	C-4	22	4730-00-221-2126	C-6	2
4730-00-186-7783	C-5	3	5935-00-223-0572	C-11	9
4730-00-186-7783	C-5	5	4730-00-223-9257	C-4	15
4730-00-186-7783	C-5	7	4730-00-223-9257	C-4	21
4730-00-186-7783	C-5	23	4730-00-223-9267	C-4	27
4730-00-186-9949	C-6	1	4730-00-223-9267	C-4	50
4730-00-186-9949	C-7	3	4730-00-230-8739	C-7	1
4730-00-187-0085	C-4	40	4730-00-240-5905	C-4	14
4730-00-187-0085	C-4	45	4730-00-240-5905	C-4	20
4730-00-187-0085	C-5	32	4730-00-240-5905	C-9	5
4730-00-187-0085	C-5	36	4730-00-240-5905	C-10	1
4730-00-187-0085	C-5	42	5320-00-242-1579	C-3	2
4730-00-187-0085	C-5	47	5320-00-242-1579	C-3	14
5320-00-242-1579	C-3	20	5365-00-663-2125	C-12	5
5305-00-273-7352	C-5	15	5365-00-663-2125	C-13	4
4730-00-278-9212	C-1	9	5365-00-663-2125	C-14	6
4730-00-278-9460	C-4	69	4730-00-720-0167	C-10	3
5935-00-283-3838	C-11	1	5320-00-721-5211	C-3	10
5935-00-283-3838	C-13	1	5320-00-721-5211	C-3	17
5935-00-284-3967	C-12	1	5320-00-721-5211	C-3	19
5935-00-284-3967	C-14	9	5320-00-721-5211	C-4	75
4730-00-287-3699	C-4	39	5320-00-721-5211	C-4	92
4730-00-287-3699	C-4	43	5310-00-809-5997	C-9	7
6610-00-291-7021	C-4	106	4730-00-812-5036	C-4	100
5935-00-408-0821	C-11	2	4730-00-812-5036	C-4	104
5935-00-408-0821	C-12	3	5365-00-828-8526	C-11	4
5935-00-408-0821	C-13	2	5365-00-828-8526	C-12	4
5935-00-408-0821	C-14	8	5365-00-828-8526	C-13	3
6610-00-527-8450	C-4	98	5365-00-828-8526	C-14	7
5305-00-543-2772	C-5	20	6610-00-865-3848	C-4	13
5305-00-543-2780	C-4	57	5935-00-879-8334	C-12	8
5305-00-543-2780	C-4	60	4730-00-925-4752	C-1	10
5365-00-558-5416	C-11	7	4720-00-927-7088	C-4	71
5305-00-579-0550	C-5	16	5310-00-934-9759	C-5	2
5365-00-663-2125	C-11	3	5310-00-934-9761	C-4	9
5310-00-934-9761	C-4	55	5310-00-938-2013	C-8	12
5310-00-934-9761	C-5	4	5305-00-958-1351	C-5	17
5310-00-934-9763	C-4	12	5305-00-988-7611	C-5	8

CROSS-REFERENCE INDEXES
PART NUMBER INDEX

CAGE	PART NUMBER	STOCK NUMBER	FIGURE NO	ITEM NO
81349	AAU-31/A	6610-00-110-3368	C-4	102
96906	MS3420-69	5365-00-828-8526	C-11	4
		5365-00-828-8526	C-12	4
		5365-00-828-8526	C-13	3
		5365-00-828-8526	C-14	7
88044	AN3420-8A	5365-00-598-5394	C-11	8
88044	AN50OD8-9		C-5	18
			C-8	2
88044	AN501D3-3		C-8	5
88044	AN515B6-16	5305-00-151-0622	C-4	11
88044	AN515C6-4	5305-00-054-6650	C-4	10
88044	AN515C6-4	5305-00-054-6650	C-4	35
88044	AN515C8-4	5305-00-273-7352	C-5	15
88044	AN6227-6	5330-00-196-5368	C-4	99
		5330-00-196-5368	C-4	103
		5330-00-196-5368	C-4	107
88044	AN6270-3-0030		C-4	70
88044	AN6270-3D0100	4720-00-089-5348	C-4	68
88044	AN6270-3-120	4720-00-927-7088	C-4	71
88044	AN6270-3D0150	4720-00-481-9870	C-4	73
88044	AN6270-3D0180	4720-00-064-0833	C-4	72
88044	AN6270-4D0060	4720-00-421-1414	C-1	2
88044	AN6270-4D0072	4720-01-016-5618	C-1	3
66295	AN737-TW26-34WWD	4730-00-720-0167	C-10	3
88044	AN737TW-48	4730-00-278-9212	C-1	9
88044	AN815-4D	4730-00-925-4752	C-1	10
88044	AN816-1D		C-4	24
88044	AN816-3	4730-00-187-0839	C-4	108
88044	AN816-3D	4730-00-187-0085	C-4	40
		4730-00-187-0085	C-4	45
		4730-00-187-0085	C-5	32
		4730-00-187-0085	C-5	36
		4730-00-187-0085	C-5	42
		4730-00-187-0085	C-5	47
		4730-00-187-0085	C-6	4
88044	AN816-4D	4730-00-240-5905	C-4	14
		4730-00-240-5905	C-4	20
		4730-00-240-5905	C-9	5
		4730-00-240-5905	C-10	1
88044	AN822-3D	4730-00-278-3680	C-4	18
			C-4	25
			C-4	29
			C-4	48
			C-4	53
			C-5	34
			C-5	39
			C-5	41
			C-5	49
			C-6	3

CROSS-REFERENCE INDEXES
PART NUMBER INDEX

CAGE	PART NUMBER	STOCK NUMBER	FIGURE NO	ITEM NO
			C-7	2
			C-8	1
88044	AN823-3D	4730-00-186-9949	C-6	1
		4730-00-186-9949	C-7	3
88044	AN824-3D	4730-00-278-9460	C-4	69
88044	AN910-1D	4730-00-223-9257	C-4	15
		4730-00-223-9257	C-4	21
88044	AN911-1D	4730-00-186-7783	C-4	16
		4730-00-186-7783	C-4	22
88044	AN913-1D	4730-00-223-9267	C-4	27
		4730-00-223-9267	C-4	50
88044	AN914-1D	4730-00-230-8739	C-7	1
88044	AN916-1D	4730-00-187-1391	C-4	37
		4730-00-187-1391	C-4	44
		4730-00-187-1391	C-9	4
88044	AN917-1D	4730-00-287-3699	C-4	39
		4730-00-287-3699	C-4	43
88044	AN919-2D	4730-00-812-5036	C-4	100
		4730-00-812-5036	C-4	104
88044	AN929-3	4730-00-221-2126	C-6	2
88044	AN929A4	4730-00-585-8770	C-4	66
96906	MS16995-40	5305-00-988-7611	C-5	8
96906	MS20426A4-3	5320-00-721-5211	C-3	17
96906	MS20470-A4-6	5320-00-721-5211	C-3	10
		5320-00-721-5211	C-3	19
		5320-00-721-5211	C-4	75
		5320-00-721-5211	C-4	92
96906	MS20470-A6-7	5320-00-242-1579	C-3	2
		5320-00-242-1579	C-3	14
		5320-00-242-1579	C-3	20
96906	MS25041-7	6210-00-143-661	C-4	34
96906	MS25237-327	6240-00-155-7836	C-4	33
96906	MS27183-17	5310-00-809-5997	C-9	7
96906	MS28046T1	6610-00-859-7445	C-4	98
96906	MS25454-5	6610-01-125-0726	C-4	106
81349	M85049/41-10A	5935-01-201-9223	C-11	2
		5935-01-201-9223	C-12	3
		5935-01-201-9223	C-13	2
		5935-01-201-9223	C-14	8
81349	M85049/41-12A	5935-01-167-6148	C-11	9
96906	MS3456W18-5P	5935-01-261-8508	C-12	8
96906	MS3102R18-IP	5935-00-721-0490	C-4	59
96906	MS3456W18-IS	5935-00-622-2830	C-12	1
		5935-00-284-3967	C-14	9
96906	MS3456W18-5S	5935-01-196-6906	C-11	1
		5935-01-196-6906	C-13	1
96906	MS3456W20-4P	5935-01-069-0285	C-11	10
96906	MS3420-10	5365-00-663-2125	C-11	3
		5365-00-663-2125	C-12	5
		5365-00-663-2125	C-13	4

TM 1-4920-458-13&P
CROSS-REFERENCE INDEXES
PART NUMBER INDEX

CAGE	PART NUMBER	STOCK NUMBER	FIGURE NO	ITEM NO
		5365-00-663-2125	C-14	6
96906	MS3420-12	5365-00-558-5416	C-11	7
96906	MS35059-22	5930-00-166-2016	C-4	46
96906	MS35223-75		C-5	19
96906	MS35231-26	5305-00-579-0550	C-5	16
96906	MS35233-26	5305-00-543-2772	C-5	20
96906	MS35233-28	5305-00-045-1628	C-5	14
96906	MS35233-17	5305-00-515-7219	C-4	60
96906	MS35233-38	5305-00-943-2780	C-4	57
96906	MS35234-59	5305-00-958-1351	C-5	17
96906	MS35338-41	5310-00-045-4007	C-5	13
96906	MS35425-7	5310-01-064-8787	C-9	1
96906	MS35649-224	5310-00-938-2013	C-8	12
96906	MS35649-264	5310-00-934-9761	C-4	9
		5310-00-934-9761	C-4	55
		5310-00-934-9761	C-5	4
96906	MS35649-265	5310-00-934-9763	C-4	12
96906	MS35649-284	5310-00-934-9759	C-5	2
96906	MS51957-27	5305-00-054-6651	C-4	7
59413	P-115-A		C-7	5
59413	P-345		C-7	7
59413	100-10001		C-14	1
59413	100-10002		C-14	2
59413	100-10003		C-14	3
59413	100-10015		C-13	7
59413	10127		C-7	8
59413	11-10003		C-10	2
59413	11-10005		C-10	4
59413	11-10006-1		C-5	27
59413	11-10006-2		C-5	29
59413	11-10006-3		C-5	28
59413	11-10006-4		C-5	24
59413	11-10006-5		C-5	26
59413	11-10006-6		C-5	25
59413	11-10006-7		C-5	43
			C-5	48
59413	12-10005		C-9	3
59413	12-10006		C-6	7
59413	14-10001		C-4	49
			C-4	52
59413	14-10002		C-6	8
59413	14-10004		C-5	31
			C-6	5
59413	14-10005		C-5	44
			C-5	46
59413	14-10006		C-5	37
59413	14-10007		C-4	38
			C-4	42
59413	14-10009		C-4	28
59413	14-10010		C-4	26

TM 1-4920-458-13&P
 CROSS-REFERENCE INDEXES
 PART NUMBER INDEX

CAGE	PART NUMBER	STOCK NUMBER	FIGURE NO	ITEM NO
59413	14-10011		C-4	51
59413	14-10012		C-4	47
59413	14-10013		C-4	17
59413	14-10014		C-4	13
59413	14-10015		C-4	23
59413	14-10016		C-4	19
59413	15-10034-1		C-4	5
59413	16-10010		C-4	86
59413	17-10002		C-7	4
59413	21-10001		C-9	9
59413	21-10002		C-9	8
59413	23-10003		C-8	9
59413	23-10005		C-8	11
59413	23-10006		C-8	10
59413	3005-5		C-7	6
59413	32-10003		C-3	4
			C-3	13
59413	35-0014		C-5	51
59413	35-0015		C-8	3
59413	35-0017		C-5	22
59413	35-0019		C-5	23
59413	35-0025		C-5	9
59413	35-0026		C-5	10
59413	35-10010		C-9	6
59413	35-10040		C-8	13
59413	35-10045		C-4	89
59413	35-10061		C-3	11
59413	35-10062		C-3	16
59413	35-10063		C-3	18
59413	35-10067		C-3	5
59413	42-10010		C-4	67
59413	47-10004		C-4	4
59413	47-10014		C-4	85
59413	47-10015		C-9	2
59413	51-10013		C-4	79
			C-4	81
			C-4	88
			C-4	95
59413	51-10015		C-4	77
			C-4	83
			C-4	90
			C-4	96
59413	51-10016		C-3	9
			C-4	76
			C-4	91
59413	51-10017		C-3	6
			C-3	12
59413	55-10078		C-4	84
59413	55-10079		C-4	2
59413	60-10005		C-5	5

TM 1-4920-458-13&P
 CROSS-REFERENCE INDEXES
 PART NUMBER INDEX

CAGE	PART NUMBER	STOCK NUMBER	FIGURE NO	ITEM NO
59413	61-10015		C-3	3
59413	61-10016		C-3	7
59413	62-10050		C-8	7
59413	62-10051		C-4	78
59413	62-10053		C-4	8
59413	62-10057		C-5	21
59413	62-10058		C-2	2
59413	62-10059-1		C-4	94
59413	62-10059-2		C-4	82
59413	62-10062		C-3	15
59413	62-10064		C-3	1
59413	62-10065		C-3	8
59413	62-10066		C-4	1
59413	62-10073		C-4	61
59413	62-10074		C-4	62
59413	62-10075		C-4	63
59413	62-10076		C-4	64
59413	66-10083		C-4	32
59413	66-10084		C-4	30
59413	66-10095		C-4	56
59413	66-10096		C-5	38
59413	66-10097		C-5	33
59413	66-10098		C-5	35
59413	70-10028		C-5	7
59413	71-00003		C-5	3
59413	74-10013		C-5	52
59413	79-10006		C-8	4
59413	80-10111A		C-1	5
59413	80-10111		C-1	4
59413	80-10112A		C-1	7
59413	80-10113A		C-1	6
59413	80-10114		C-14	5
59413	80-10114A		C-11	6
			C-12	7
			C-13	6
59413	80-10128		C-12	2
			C-14	10
59413	80-10129		C-5	6
59413	80-10130A		C-12	6
59413	80-10131A		C-13	5
59413	80-10132		C-14	4
59413	80-10133A		C-11	5
59413	80-10145		C-4	65
59413	90-50025		C-2	3
59413	91-10004		C-4	6
59413	92-0003		C-5	11
59413	92-0005		C-5	50
59413	92-0006		C-5	12
59413	92-0008		C-6	6
59413	92-0009		C-5	45

TM 1-4920-458-13&P
CROSS-REFERENCE INDEXES
PART NUMBER INDEX

CAGE	PART NUMBER	STOCK NUMBER	FIGURE NO	ITEM NO
59413	92-0010		C-5	40
59413	92-0011		C-5	1
59413	92-0012		C-5	30
59413	92-10113		C-1	11
59413	92-10114-6		C-1	1
59413	92-10116		C-4	58
59413	92-10118		C-1	8
59413	92-10119		C-8	8
59413	92-10120		C-8	6
59413	92-10128		C-4	36
59413	92-10129		C-4	41
59413	92-10130		C-4	31
59413	92-10131		C-2	1
59413	92-10132		C-4	97
59413	92-10133		C-4	101
59413	92-10134		C-4	105
59413	92-10135		C-4	80
59413	92-10136		C-4	87
59413	92-10137		C-4	74
59413	92-10141		C-4	93
59413	98-10011		C-4	54
59413	98-10015		C-4	3

APPENDIX D

EXPENDABLE/DURABLE SUPPLIES AND MATERIALS LIST

Section I. Introduction

D-1. SCOPE

This appendix list expendable supplies and materials you will need to operate and maintain the Pitot and Static Systems Tester. These items are authorized to you by CTA 50-970, Expendable Items (Except Medical, Class V, Repair Parts, and Heraldic Items).

D-2. EXPLANATION OF COLUMNS

- a. Column (1). Item Number. This number is assigned to the entry in the listing.
- b. Column (2). Level. This column identifies the lowest level of maintenance that requires the listed item.

(enter as applicable)
C - Operator/Crew
O - Organizational Maintenance
F - Direct Support Maintenance
H - General Support Maintenance
- c. Column (3). National Stock Number. This is the National Stock number assigned to the item; use it to request or requisition the item.
- d. Column (4). Description. Indicates the Federal item name and if required, a description to identify the item. The last line for each parentheses followed by the part number.
- e. Column (5). Unit of Measure (U/M). Indicates the measure used in performing the actual maintenance function. This measure is expressed by a two-character alphabetical abbreviations (e.g., ea. in pr). If the unit of measure differs from the unit of issue, requisition the lowest unit of issue that will satisfy you requirements.

EXPENDABLE/DURABLE SUPPLIES AND MATERIALS LIST

(1) ITEM NUMBER	(2) LEVEL	(3) NATIONAL STOCK NUMBER	(4) DESCRIPTION	(5) UNIT OF MEASURE (U/M)
1	0	5975-01-230-8385	Cable Ties SST2SM, (06383)	EA
2	F		Heat Shrink Insulation Sleeving, M2305317-103-0, -104-0, -105-0	
3	0	9150-00-252-6383	Hydraulic Oil, MIL-H-5606	QT
4	F	6810-00-983-8551	Isopropyl Alcohol, TT-I-735	OZ
5	F	3439-01-132-6137	Solder, QQ-S-571, SN63, Rosin Type RMA	LB
6	F		Seal Lube Ohio Industries Lab, 250 Mahoning Ave. Cleveland, Ohio 44113	PT

APPENDIX E**MANUFACTURED ITEMS LIST**

E-1. GENERAL

This appendix contains the procedures for fabricating the manufactured items you are authorized to make.

E-2. WIRING - MANUFACTURE

This task covers: Fabrication

Personnel Required:

MOS 68F Aircraft Electrician

FABRICATION:

- a. Cut a suitable length of wire from a spool of bulk wire.

NOTE

Be sure the wire you cut is the same gage as the wire you are replacing. Identify wire by using color coded tape, the same color as the wire you are replacing.

- b. Note what type and size of connector the old wire had and match them for the new wire.
- c. Measure the length of the old wire. When cutting the new wire, add 6 in. to this length.

NOTE

If splicing a wire, use heat shrink tubing over spliced area.

- d. Fasten the first connector splice to one end of the wire.

NOTE

Check new wire for continuity before installation.

- e. Install the wire, following the path of the old wire as much as possible.
- f. Fasten the wire in place with tape, nylon ties or shrink wrap.
- g. If wire is spliced and heat shrink tubing is used, shrink tubing using a suitable heat source.

E-1/(E-2 blank)

APPENDIX F

TORQUE LIMITS

Table F-1 gives the standard torque values for studs, nuts, bolts, and screws. Exceptions to the following values are given in the maintenance task where appropriate.

TABLE F-1. Standard Torque Limits

THREAD DIAMETER SCREW SIZE NO.	THREADS PER INCH	STANDARD TORQUE 1 LB FT.
Use these torques for bolts and nuts with standard threads.		
8		17 Max
2	56	
10	24	
Use these torques for bolts and nuts on hydraulic valve bodies with standard threads.		
6	32	
10	32	2.0

NOTE

To determine breakaway torque, thread nut onto screw or bolt until at least two threads stick out. Nut shall not make contact with a mating part. Stop the nut. Torque necessary to begin turning nut again is the breakaway torque. Do not reuse self-locking nuts that do not meet minimum breakaway torque.

APPENDIX G

ELECTRICAL SCHEMATICS

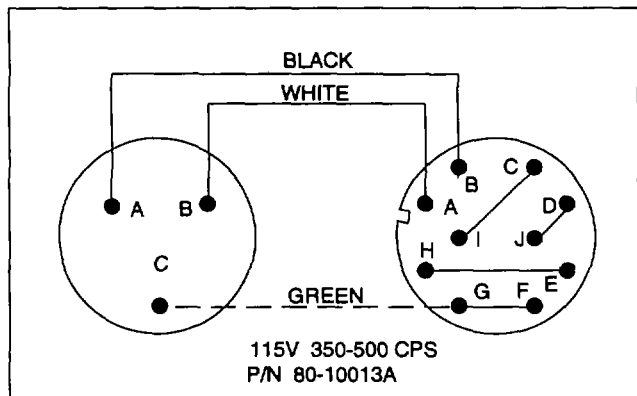
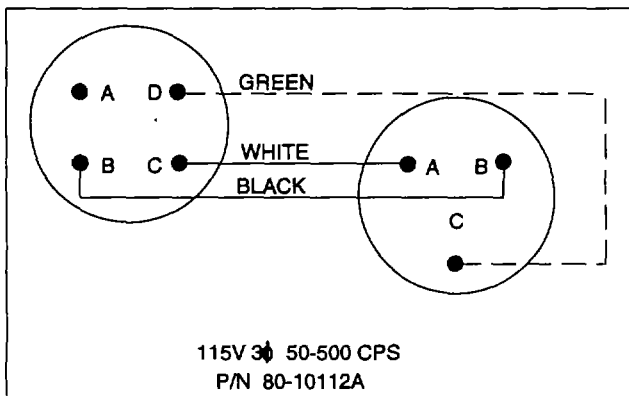
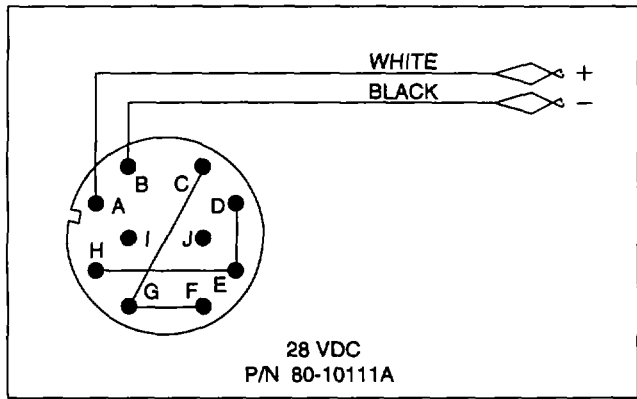
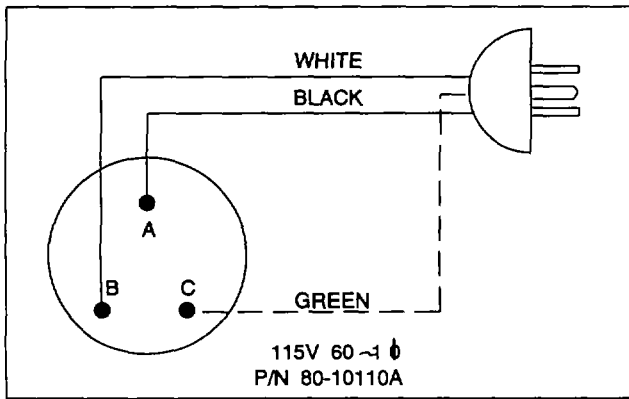
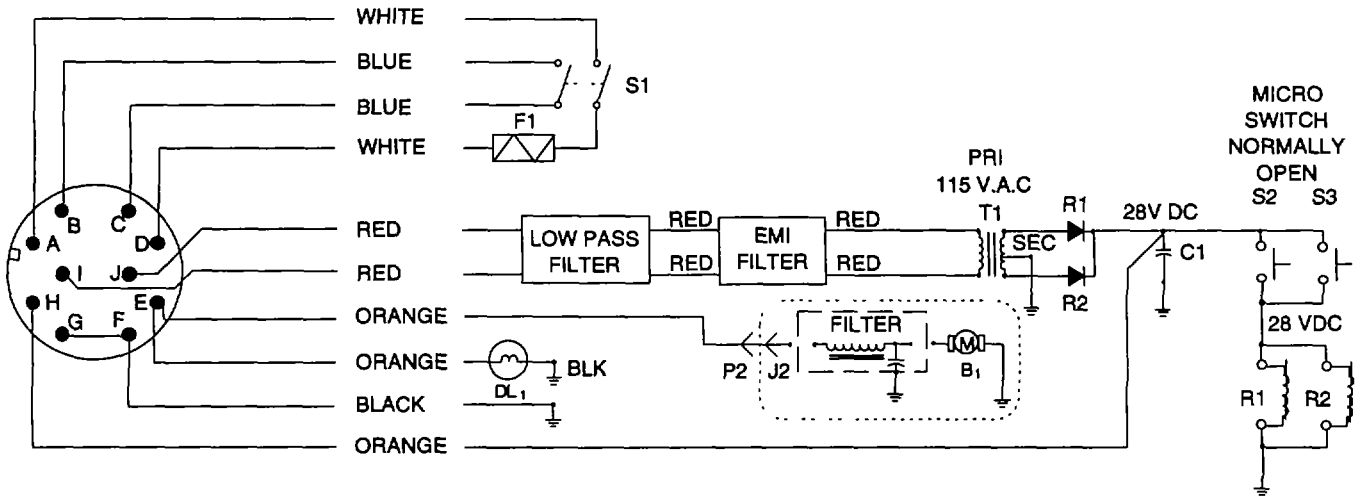

ELECTRICAL HOOKUP

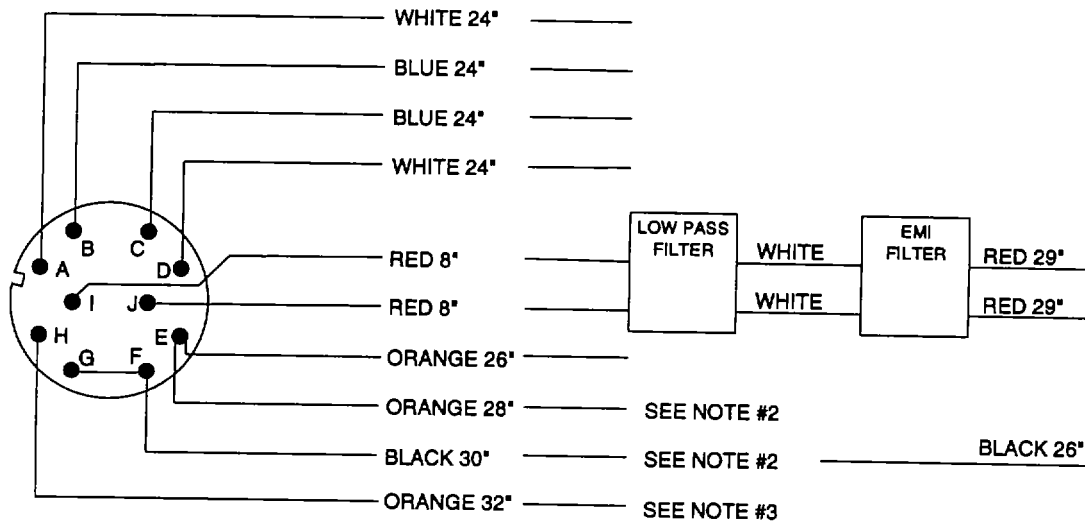

NOTES:

1. ALL WIRE-GLASS BRD. LW PER MIL-W-76A.
2. CRIMP TERMINAL -12 TO 10 WIRE GAGE, INSULATED STYLE, SCREW SIZE 1/4", 2 REQD.
3. STRAIGHT PLUG AN 3106A-105-25 WITH CABLE CLAMP AN 3057-3A AND AN 3420-3 BOOT.
4. SOLDER PER MIL-S-6872. SOLDER COMP. QQ-S-571, SN63WS.
5. CLEAR P.V.C. "SPAGHETTI", P.V.C.-105-10, C.I.D. 70331, LENGTH AR TO COVER PINS OF COI

WIRING HARNESS ASSEMBLY

INDEX

Subject

Paragraph

A

ACCESSORY STORAGE INSPECTION.....	3-14
ADMINISTRATIVE STORAGE	1-4

B

BEFORE YOU OPERATE.....	2-4
-------------------------	-----

C

CALIBRATION	4-10
CLEANING.....	3-8
CONTROL AND INDICATORS	2-3

D

DESCRIPTION AND LOCATION OF MAJOR COMPONENTS	1-8
DESTRUCTION OF ARMY MATERIEL TO PREVENT ENEMY USE	1-3
DRAINING THE OIL SUMPS	3-10

E

ELECTRICAL HOOKUP.....	G-1
ELECTRICAL SCHEMATICSAPPENDIX G
EXPENDABLE/DURABLE SUPPLIES AND MATERIAL LIST	APPENDIX D
EXTREME ENVIRONMENTAL MAINTENANCE	2-9 & 4-9

F

FILLING OIL RESERVOIR	3-9
FUNCTION (PITOT AND STATIC SYSTEMS TESTER)	1-6
FUSE, REMOVAL AND REPLACEMENT	3-15

H

HARNESS ASSEMBLY, WIRING	G-2
--------------------------------	-----

INDEX

<u>Subject</u>	<u>Paragraph</u>
I	
INSPECTION ACCESSORIES STORAGE	3-14
INSPECTION/FAULT ISOLATION, PITOT AND STATIC SYSTEMS TESTER	412
INSPECTION, PITOT AND STATIC SYSTEMS TESTER.....	3-13
INSTALLATION:	
AIRSPEED INDICATOR.....	4-19
AIRSPEED SHUT-OFF VALVE.....	4-23
ALTIMETER.....	4-18
ALTIMETER SHUT-OFF VALVE	4-22
BELLOWS.....	4-45
CAPACITOR.....	4-35
CHECK VALVES	4-43
EMI FILTER	4-37
FUSE	3-15
FUSE HOLDER	4-27
HOSES AND FITTINGS (TYPICAL).....	4-30
LAMP (BULB).....	3-16
LIGHT ASSEMBLY	4-28
MOTOR/PUMP	4-33
METERING VALVE (TYPICAL)	4-25
OIL FILTER	4-32
OIL RESERVOIR AND/OR FILL AND RUN SELECTOR VALVE.....	4-41
OIL SUMP (TYPICAL)	4-31

INDEX

Subject

Paragraph

I (CONT)

INSTALLATION: (CONT)

OVER PRESSURE RELIEF VALVE.....	4-29
POWER CONNECTOR	4-38
PRESSURE THREE WAY SELECTOR VALVE	4-20
PUMP AND/OR MOTOR ASSEMBLY.....	4-34
RATE OF CLIMB INDICATOR.....	4-17
RATE OF CLIMB TWO-WAY SHUT-OFF VALVE.....	4-21
DIODE PLATE	4-39
RIGID PRESSURE LINES (TYPICAL).....	4-42
SOLENOID VALVES.....	4-44
TOGGLE SWITCH.....	4-26
TRANSFORMER	4-36
VACUUM TWO-WAY SHUT-OFF VALVE	4-24
INSTRUMENT CONTROLS	2-3

K

KNOB (SEE VALVES)

L

LOCATION AND DESCRIPTION OF MAJOR COMPONENTS	1-8
LUBRICATION.....	4-8
LUBRICATION LEVEL CHECK	2-10

INDEX

Subject

Paragraph

M

MAINTENANCE ALLOCATION CHART	APPENDIX B
MAINTENANCE FORMS, RECORDS, AND REPORTS.....	1-2
MAINTENANCE OPERATIONS.....	3-2
MAINTENANCE PROCEUDRES - GENERAL	4-15
MANUFACTURED ITEM LIST	APPENDIX E

O

OPERATION UNDER USUAL CONDITIONS:	
OPERATING PROCEDURES	2-6
OPERATION UNDER UNUSUAL CONDITIONS:	
UNUSUAL CONDITIONS.....	2-8
EXTREME ENVIRONMENTAL MAINTENANCE.....	2-9
OPERATOR PREVENTIVE CHECKS AND SERVICES:	
BEFORE YOU OPERATE	2-4
PERFORMANCE CHECK	2-5
OIL RESERVOIR FILLING PROCEDURES	3-9
OIL SUMPS DRAINING PROCEDURES.....	3-10

P

PERFORMANCE CHECKS	3-11
PITOT AND STATIC SYSTEMS TESTER INSPECTION	3-13
PITOT AND STATIC SYSTEMS TESTER INSPECTION/FAULT ISOLATION	4-12
PITOT AND STATIC SYSTEMS TESTER CALIBRATION.....	4-16
POWER, INPUT	1-7
PRE-OPERATION PROCEDURES.....	2-2

INDEX

Subject

Paragraph

P (CONT)

PREPARATION FOR SHIPMENT	3-18
PREPARATION FOR STORAGE.....	3-17
PREVENTIVE MAINTENANCE CHECKS AND SERVICES (PMCS), GENERAL.	3-7 & 4-6
PRINCIPLES OF OPERATION	1-10

R

REFERENCES	APPENDIX A
------------------	------------

REMOVAL:

AIRSPEED INDICATOR.....	4-19
AIRSPEED SHUT-OFF VALVE	4-23
ALTIMETER	4-18
ALTIMETER SHUT-OFF VALVE.....	4-22
BELLOWS.....	4-45
CAPACITOR.....	4-35
CHECK VALVES	4-43
EMI FILTER	4-37
FUSE.....	3-15
FUSE HOLDER.....	4-27
HOSES AND FITTINGS (YPICAL).....	4-30
LAMP (BULB).....	3-16
LIGHT ASSEMBLY.....	4-28
MOTOR/PUMP	4-33
METERING VALVE (TYPICAL)	4-25

INDEX

Subject

Paragraph

R (CONT)

REMOVAL: (CONT)

OIL FILTER.....	4-32
OIL RESERVOIR AND/OR FILL AND RUN SELECTOR VALVE	4-41
OIL SUMP (TYPICAL)	4-31
OVER PRESSURE RELIEF VALVE.....	4-29
POWER CONNECTOR	4-38
PRESSURE THREE WAY SELECTOR VALVE	4-20
PUMP AND/OR MOTOR ASSEMBLY	4-34
RATE OF CLIMB INDICATOR	4-17
RATE OF CLIMB TWO-WAY SHUT-OFF VALVE	4-21
DIODE PLATE.....	4-39
RIGID PRESSURE LINES (TYPICAL).....	4-42
SOLENOID VALVES	4-44
TOGGLE SWITCH	4-26
TRANSFORMER	4-36
VACUUM TWO-WAY SHUT-OFF VALVE	4-24
REPAIR PARTS	3-5
REPAIR PARTS AND SPECIAL TOOLS LIST	APPENDIX C
REPAIR PARTS, SPECIAL TOOLS, TMDE, AND SUPPORT EQUIPMENT, GENERAL	4-1
MAINTENANCE OPERATIONS.....	4-2
TOOLS AND TEST EQUIPMENT LIST	4-3
REPAIR PARTS.....	4-4
REPAIR WIRING HARNESS	4-40

INDEX

Subject

Paragraph

R (CONT)

REPORTING EQUIPMENT IMPROVEMENT RECOMMENDATIONS (EIRs)

1-5

S

SERVICE UPON RECEIPT, GENERAL

3-6 & 4-5

SHUT DOWN PROCEDURES

2-7

SPECIAL TOOLS, TMDE, AND SUPPORT EQUIPMENT

3-4

T

TABLE 1-1 EQUIPMENT DATA

1-9

TABLE 2-1 OPERATOR/CRES PREVENTATIVE MAINTENANCE CHECK
AND SERVICES

2-4

TABLE 2-2 PERFORMANCE CHECK

2-5

TOOLS AND TEST EQUIPMENT LIST

3-3

TORQUE LIMITS

APPENDIX F

TROUBLESHOOTING, GENERAL

3-12 & 4-11

TROUBLESHOOTING PROCEDURE 1: MOTOR AND/OR INDICATOR
LAMP DOES NOT TURN ON

4-13

TROUBLESHOOTING PROCEDURE 2: TESTER DOES NOT BUILD OR
HOLD PRESSURE (AIRSPEEDNACUUM ALTIMETER)

4-14

U

UNUSUAL CONDITIONS.....

2-8

V

VALVES:

AIRSPEED SHUT-OFF VALVE

4-23

ALTIMETER SHUT-OFF VALVE

4-22

CHECK VALVES

4-43

FILL AND RUN SELECTOR VALVE.....

4-41

INDEX

Subject

Paragraph

V (CONT)

VALVES: (CONT)

METERING VALVE (TYPICAL)	4-25
PRESSURE THREE WAY SELECTOR VALVE	4-20
RATE OF CLIMB TWO-WAY SHUT-OFF VALVE.....	4-21
SOLENOID VALVES.....	4-44
VACUUM TWO-WAY SHUT-OFF VALVE	4-24

W

WIRING HARNESS ASSEMBLY.....	APPENDIX G
WIRING HARNESS, REPAIR	4-40

TM 1-4920-458-13&P

By Order of the Secretary of the Army:

GORDON R. SULLIVAN
General, United States Army
Chief of Staff

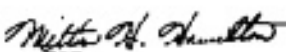
Official: 

MILTON H. HAMILTON
Administrative Assistant to the
Secretary of the Army
06784

DISTRIBUTION:

To be distributed in accordance with DA Form 12-31 -E, block no. 3430, requirements for TM 1-4920-458-13&P.

RECOMMENDED CHANGES TO EQUIPMENT TECHNICAL PUBLICATIONS

 <p style="text-align: center;"><i>THEN...JOT DOWN THE DOPE ABOUT IT ON THIS FORM. CAREFULLY TEAR IT OUT, FOLD IT AND DROP IT IN THE MAIL.</i></p>		SOMETHING WRONG WITH PUBLICATION	
		FROM: (PRINT YOUR UNIT'S COMPLETE ADDRESS)	
		DATE SENT	
PUBLICATION NUMBER		PUBLICATION DATE	PUBLICATION TITLE
IN THIS SPACE, TELL WHAT IS WRONG AND WHAT SHOULD BE DONE ABOUT IT.			
BE EXACT PIN-POINT WHERE IT IS			
PAGE NO.	PARA-GRAPH	FIGURE NO.	TABLE NO.
PRINTED NAME, GRADE OR TITLE AND TELEPHONE NUMBER		SIGN HERE	

The Metric System and Equivalents

Linear Measure

1 centimeter = 10 millimeters = .39 inch
 1 decimeter = 10 centimeters = 3.94 inches
 1 meter = 10 decimeters = 39.37 inches
 1 dekameter = 10 meters = 32.8 feet
 1 hectometer = 10 dekameters = 328.08 feet
 1 kilometer = 10 hectometers = 3,280.8 feet

Weights

1 centigram = 10 milligrams = .15 grain
 1 decigram = 10 centigrams = 1.54 grains
 1 gram = 10 decigrams = .035 ounce
 1 dekagram = 10 grams = .35 ounce
 1 hectogram = 10 dekagrams = 3.52 ounces
 1 kilogram = 10 hectograms = 2.2 pounds
 1 quintal = 100 kilograms = 220.46 pounds
 1 metric ton = 10 quintals = 1.1 short tons

Liquid Measure

1 centiliter = 10 milliliters = .34 fl. ounce
 1 deciliter = 10 centiliters = 3.38 fl. ounces
 1 liter = 10 deciliters = 33.81 fl. ounces
 1 dekaliter = 10 liters = 2.64 gallons
 1 hectoliter = 10 dekaliters = 26.42 gallons
 1 kiloliter = 10 hectoliters = 264.18 gallons

Square Measure

1 sq. centimeter = 100 sq. millimeters = .155 sq. inch
 1 sq. decimeter = 100 sq. centimeters = 15.5 sq. inches
 1 sq. meter (centare) = 100 sq. decimeters = 10.76 sq. feet
 1 sq. dekameter (are) = 100 sq. meters = 1,076.4 sq. feet
 1 sq. hectometer (hectare) = 100 sq. dekameters = 2.47 acres
 1 sq. kilometer = 100 sq. hectometers = .386 sq. mile

Cubic Measure

1 cu. centimeter = 1000 cu. millimeters = .06 cu. inch
 1 cu. decimeter = 1000 cu. centimeters = 61.02 cu. inches
 1 cu. meter = 1000 cu. decimeters = 35.31 cu. feet

Approximate Conversion Factors

<i>To change</i>	<i>To</i>	<i>Multiply by</i>	<i>To change</i>	<i>To</i>	<i>Multiply by</i>
inches	centimeters	2.540	ounce-inches	Newton-meters	.007062
feet	meters	.305	centimeters	inches	.394
yards	meters	.914	meters	feet	3.280
miles	kilometers	1.609	meters	yards	1.094
square inches	square centimeters	6.451	kilometers	miles	.621
square feet	square meters	.093	square centimeters	square inches	.155
square yards	square meters	.836	square meters	square feet	10.764
square miles	square kilometers	2.590	square meters	square yards	1.196
acres	square hectometers	.405	square kilometers	square miles	.386
cubic feet	cubic meters	.028	square hectometers	acres	2.471
cubic yards	cubic meters	.765	cubic meters	cubic feet	35.315
fluid ounces	milliliters	29,573	cubic meters	cubic yards	1.308
pints	liters	.473	milliliters	fluid ounces	.034
quarts	liters	.946	liters	pints	2.113
gallons	liters	3.785	liters	quarts	1.057
ounces	grams	28.349	liters	gallons	.264
pounds	kilograms	.454	grams	ounces	.035
short tons	metric tons	.907	kilograms	pounds	2.205
pound-feet	Newton-meters	1.356	metric tons	short tons	1.102
pound-inches	Newton-meters	.11296			

Temperature (Exact)

°F	Fahrenheit temperature	5/9 (after subtracting 32)	Celsius temperature	°C
----	---------------------------	-------------------------------	------------------------	----

PIN: 072675-000